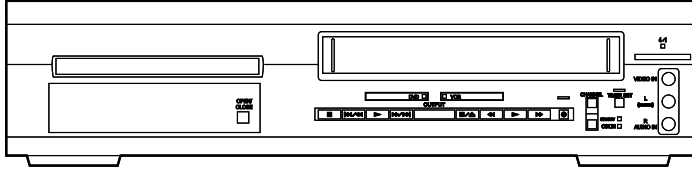


# HITACHI

## SERVICE MANUAL

No. 9208E

# DVPF2E DVPF2EUK



SHOWVIEW

VIDEO *Plus+*



COMPACT  
disc  
DIGITAL AUDIO

SPECIFICATIONS AND PARTS ARE SUBJECT TO CHANGE FOR IMPROVEMENT

## DVD PLAYER & VIDEO CASSETTE RECORDER

July

2002

Digital Media Division

# CONTENTS

<b>CHAPTER 1</b>	<b>GENERAL INFORMATION</b>
------------------	----------------------------

<b>SPECIFICATIONS</b> .....	E1-1-1
<b>LASER BEAM SAFETY PRECAUTIONS</b> .....	E1-2-1
<b>IMPORTANT SAFETY PRECAUTIONS</b> .....	E1-3-1
Product Safety Notice .....	E1-3-1
Precautions during Servicing .....	E1-3-1
Safety Check after Servicing .....	E1-3-2
<b>STANDARD NOTES FOR SERVICING</b> .....	E1-4-1
Circuit Board Indications .....	E1-4-1
Instructions for Connectors .....	E1-4-1
How to Remove/Install Flat Pack-IC .....	E1-4-1
Instructions for Handling Semi-conductors .....	E1-4-3
<b>PREPARATION FOR SERVICING</b> .....	E1-5-1
How to Enter the Service Mode .....	E1-5-1
<b>OPERATING CONTROLS AND FUNCTIONS</b> .....	E1-6-1
<b>FIRMWARE RENEWAL MODE</b> .....	E1-7-1
<b>TROUBLESHOOTING</b> .....	E1-8-1

<b>CHAPTER 2</b>	<b>DISASSEMBLY AND ADJUSTMENT</b>
------------------	-----------------------------------

<b>CABINET DISASSEMBLY INSTRUCTIONS</b> .....	E2-1-1
1. Disassembly Flowchart .....	E2-1-1
2. Disassembly Method .....	E2-1-1
<b>DISASSEMBLY/ASSEMBLY PROCEDURES OF DECK MECHANISM</b> .....	E2-2-1
<b>ALIGNMENT PROCEDURES OF MECHANISM</b> .....	E2-3-1
<b>ELECTRICAL ADJUSTMENT INSTRUCTIONS</b> .....	E2-4-1
Test Equipment Required .....	E2-4-1
Head Switching Position Adjustment .....	E2-4-1
<b>FIXTURE AND TAPE FOR ADJUSTMENT</b> .....	E2-5-1
How To Use The Fixtures And Tape .....	E2-5-1
<b>MECHANICAL ALIGNMENT PROCEDURES</b> .....	E2-6-1
Service Information .....	E2-6-1
1. Tape Interchangeability Alignment .....	E2-6-2
1-A.Preliminary/Final Checking and Alignment of Tape Path .....	E2-6-3
1-B.X Value Alignment .....	E2-6-3
1-C.Checking/Adjustment of Envelope Waveform .....	E2-6-4
1-D.Azimuth Alignment of Audio/Control/Erase Head .....	E2-6-4
<b>STANDARD MAINTENANCE</b> .....	E2-7-1
Service Schedule of Components .....	E2-7-1
Cleaning .....	E2-7-2

<b>CHAPTER 3</b>	<b>EXPLODED VIEWS AND PARTS LIST</b>
------------------	--------------------------------------

<b>EXPLODED VIEWS</b> .....	3-1-1
Cabinet .....	3-1-1
Deck Mechanism View 1 .....	3-1-2
Deck Mechanism View 2 .....	3-1-2
Deck Mechanism View 3 .....	3-1-3
<b>REPLACEMENT PARTS LIST</b> .....	3-2-1
Mechanical Parts List .....	3-2-1
Electrical Parts List .....	3-2-3

<b>CHAPTER 4</b>	<b>SCHEMATIC AND BLOCK DIAGRAMS/CBA'S</b>
------------------	---

<b>SCHEMATIC DIAGRAMS/CBA'S AND TEST POINTS</b> .....	4-1-1
<b>&lt;VCR SECTION&gt;</b>	
Wiring Diagram .....	4-1-3
Main 1/8 Schematic Diagram .....	4-1-4
Main 2/8 Schematic Diagram .....	4-1-5
Main 3/8 Schematic Diagram .....	4-1-6
Main 4/8 Schematic Diagram .....	4-1-7
Main 5/8 Schematic Diagram .....	4-1-8
Main 6/8 Schematic Diagram .....	4-1-9
Waveforms .....	4-1-10
Main 7/8 Schematic Diagram .....	4-1-11
Main 8/8 Schematic Diagram .....	4-1-12
Power Supply Schematic Diagram .....	4-1-13
Function Schematic Diagram .....	4-1-14
Front Jack Schematic Diagram .....	4-1-15
AFV Schematic Diagram .....	4-1-16
Main CBA Top View .....	4-1-17
Main CBA Bottom View .....	4-1-18
Power Supply CBA Top/Bottom View .....	4-1-19
Function CBA Top/Bottom View .....	4-1-20
Front Jack CBA Top/Bottom View .....	4-1-21
AFV CBA Top/Bottom View .....	4-1-22
Junction-A CBA Top/Bottom View .....	4-1-22
Junction-B CBA Top/Bottom View .....	4-1-22
<b>&lt;DVD SECTION&gt;</b>	
Wiring Diagram .....	4-1-23
DVD Main 1/4 Schematic Diagram .....	4-1-24
DVD Main 2/4 Schematic Diagram .....	4-1-25
DVD Main 3/4 Schematic Diagram .....	4-1-26
DVD Main 4/4 Schematic Diagram .....	4-1-27
<b>BLOCK DIAGRAMS</b> .....	4-2-1
<b>&lt;VCR SECTION&gt;</b>	
Servo/System Control Block Diagram .....	4-2-1
Video Block Diagram .....	4-2-2
Audio Block Diagram .....	4-2-3
Hi-Fi Audio Block Diagram .....	4-2-4
Power Supply Block Diagram .....	4-2-5
<b>&lt;DVD SECTION&gt;</b>	
DVD System Control Block Diagram .....	4-2-6
RF Signal Process/Servo Block Diagram .....	4-2-7
DVD Signal Process Block Diagram .....	4-2-8
DVD Video Block Diagram .....	4-2-9
DVD Audio Block Diagram .....	4-2-10
<b>SYSTEM CONTROL TIMING CHARTS</b> .....	4-3-1
<b>IC PIN FUNCTION DESCRIPTIONS</b> .....	4-4-1
<b>LEAD IDENTIFICATIONS</b> .....	4-5-1

**SPECIFICATIONS**

Product type:	DVD/VCR player with Video Cassette Recorder
Discs:	DVD video Audio CD Video Cassette tape
Converter output:	UHF Channel 22 to 69.
Power source:	220-240V +/- 10%, 50Hz +/- 0.5%
Power consumption:	30 W (standby: 5.7 W)
Operating temperature:	5°C to 40°C
Dimensions:	W 17-1/8" (435 mm) H 4" (99 mm) D 10-1/2" (266 mm)
Weight:	8.8 lbs (4 kg)

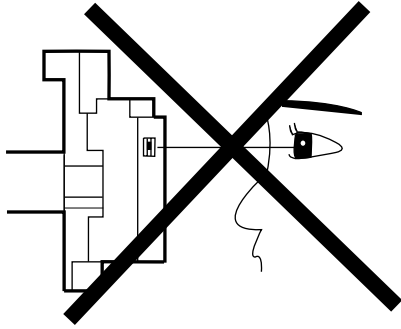
- **Designs and specifications are subject to change without notice.**

Manufactured under license from Dolby Laboratories. "Dolby" and the double-D symbol are trademarks of Dolby Laboratories.

"DTS" and "DTS Digital Out" are trademarks of Digital Theater Systems Inc.

# LASER BEAM SAFETY PRECAUTIONS

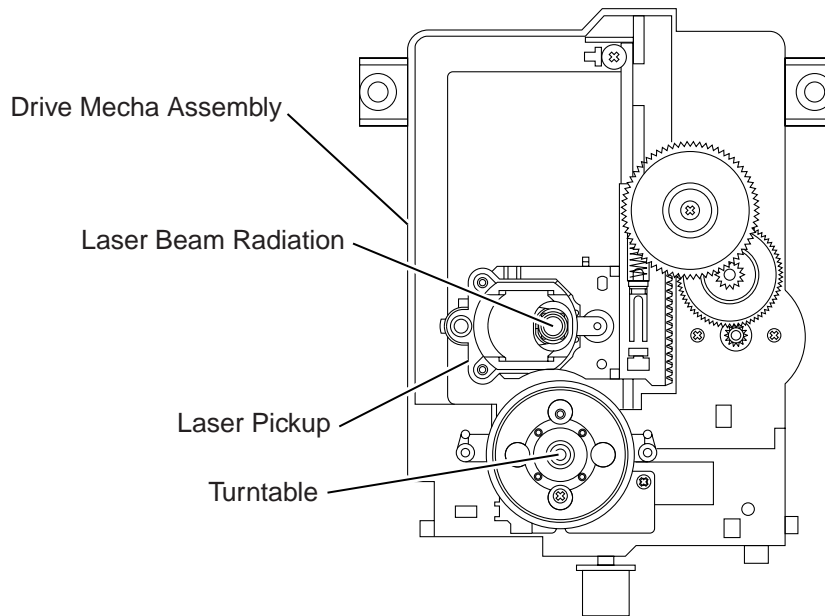
This DVD player uses a pickup that emits a laser beam.



**Do not look directly at the laser beam coming from the pickup or allow it to strike against your skin.**

The laser beam is emitted from the location shown in the figure. When checking the laser diode, be sure to keep your eyes at least 30cm away from the pickup lens when the diode is turned on. Do not look directly at the laser beam.

**Caution:** Use of controls and adjustments, or doing procedures other than those specified herein, may result in hazardous radiation exposure.



**CAUTION - VISIBLE LASER RADIATION WHEN OPEN AND INTERLOCK DEFEATED. AVOID EXPOSURE TO BEAM.**



**Location: Inside Top of DVD mechanism.**

# IMPORTANT SAFETY PRECAUTIONS

## Product Safety Notice

Some electrical and mechanical parts have special safety-related characteristics which are often not evident from visual inspection, nor can the protection they give necessarily be obtained by replacing them with components rated for higher voltage, wattage, etc. Parts that have special safety characteristics are identified by a  $\triangle$  on schematics and in parts lists. Use of a substitute replacement that does not have the same safety characteristics as the recommended replacement part might create shock, fire, and/or other hazards. The Product's Safety is under review continuously and new instructions are issued whenever appropriate. Prior to shipment from the factory, our products are carefully inspected to confirm with the recognized product safety and electrical codes of the countries in which they are to be sold. However, in order to maintain such compliance, it is equally important to implement the following precautions when a set is being serviced.

## Precautions during Servicing

- A. Parts identified by the  $\triangle$  symbol are critical for safety. Replace only with part number specified.
- B. In addition to safety, other parts and assemblies are specified for conformance with regulations applying to spurious radiation. These must also be replaced only with specified replacements.  
Examples: RF converters, RF cables, noise blocking capacitors, and noise blocking filters, etc.
- C. Use specified internal wiring. Note especially:
  - 1) Wires covered with PVC tubing
  - 2) Double insulated wires
  - 3) High voltage leads
- D. Use specified insulating materials for hazardous live parts. Note especially:
  - 1) Insulation tape
  - 2) PVC tubing
  - 3) Spacers
  - 4) Insulators for transistors
- E. When replacing AC primary side components (transformers, power cord, etc.), wrap ends of wires securely about the terminals before soldering.
- F. Observe that the wires do not contact heat producing parts (heatsinks, oxide metal film resistors, fusible resistors, etc.).
- G. Check that replaced wires do not contact sharp edges or pointed parts.
- H. When a power cord has been replaced, check that 5 - 6 kg of force in any direction will not loosen it.
- I. Also check areas surrounding repaired locations.
- J. Be careful that foreign objects (screws, solder droplets, etc.) do not remain inside the set.
- K. Crimp type wire connector  
The power transformer uses crimp type connectors which connect the power cord and the primary side of the transformer. When replacing the transformer, follow these steps carefully and precisely to prevent shock hazards.  
Replacement procedure
  - 1) Remove the old connector by cutting the wires at a point close to the connector.  
**Important:** Do not re-use a connector. (Discard it.)
  - 2) Strip about 15 mm of the insulation from the ends of the wires. If the wires are stranded, twist the strands to avoid frayed conductors.
  - 3) Align the lengths of the wires to be connected. Insert the wires fully into the connector.
  - 4) Use a crimping tool to crimp the metal sleeve at its center. Be sure to crimp fully to the complete closure of the tool.
- L. When connecting or disconnecting the internal connectors, first, disconnect the AC plug from the AC outlet.

# Safety Check after Servicing

Examine the area surrounding the repaired location for damage or deterioration. Observe that screws, parts, and wires have been returned to their original positions. Afterwards, do the following tests and confirm the specified values to verify compliance with safety standards.

## 1. Clearance Distance

When replacing primary circuit components, confirm specified clearance distance (d) and (d') between soldered terminals, and between terminals and surrounding metallic parts. (See Fig. 1)

**Table 1 : Ratings for selected area**

AC Line Voltage	Clearance Distance (d) (d')
230 V	$\geq 3\text{mm}(d)$ $\geq 6\text{ mm}(d')$

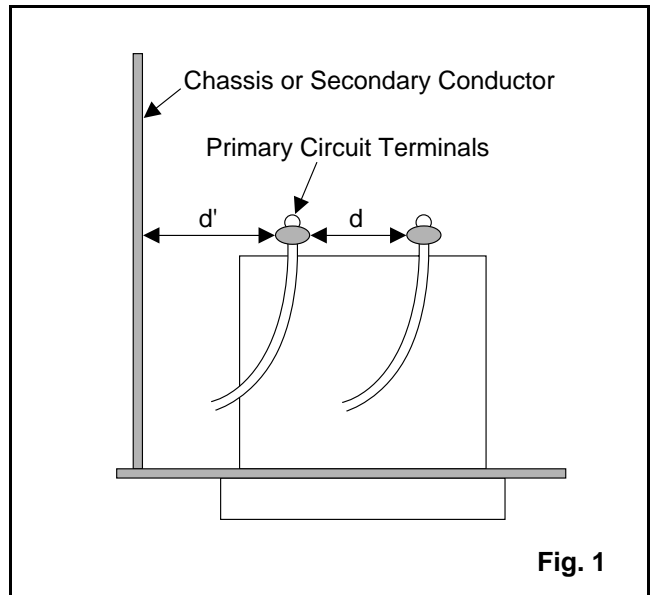
**Note:** This table is unofficial and for reference only. Be sure to confirm the precise values.

## 2. Leakage Current Test

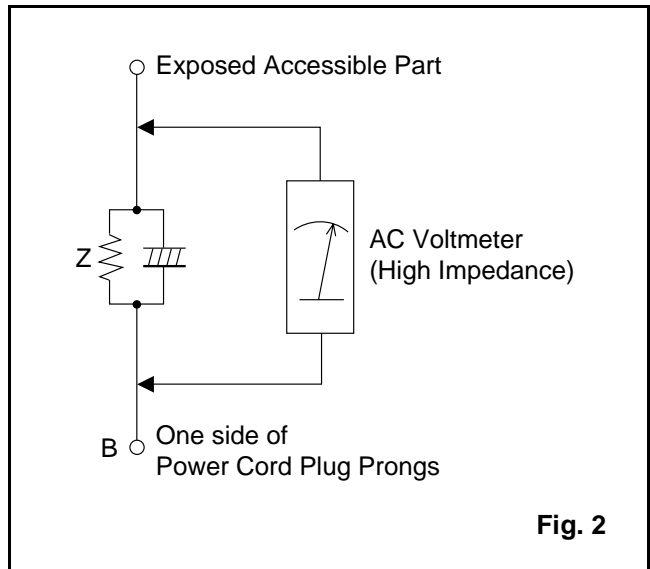
Confirm the specified (or lower) leakage current between B (earth ground, power cord plug prongs) and externally exposed accessible parts (RF terminals, antenna terminals, video and audio input and output terminals, microphone jacks, earphone jacks, etc.) is lower than or equal to the specified value in the table below.

### Measuring Method (Power ON) :

Insert load Z between B (earth ground, power cord plug prongs) and exposed accessible parts. Use an AC voltmeter to measure across the terminals of load Z. See Fig. 2 and the following table.



**Fig. 1**



**Fig. 2**

**Table 2: Leakage current ratings for selected areas**

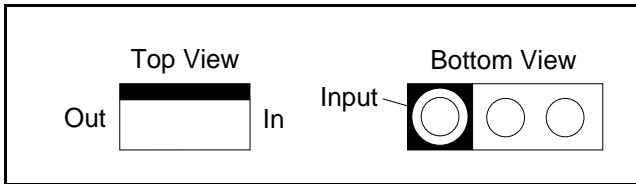
AC Line Voltage	Load Z	Leakage Current (i)	One side of power cord plug prongs (B) to:
230 V	2kΩ RES. Connected in parallel	$i \leq 0.7\text{mA AC Peak}$ $i \leq 2\text{mA DC}$	RF or Antenna terminals
	50kΩ RES. Connected in parallel	$i \leq 0.7\text{mA AC Peak}$ $i \leq 2\text{mA DC}$	A/V Input, Output

**Note:** This table is unofficial and for reference only. Be sure to confirm the precise values.

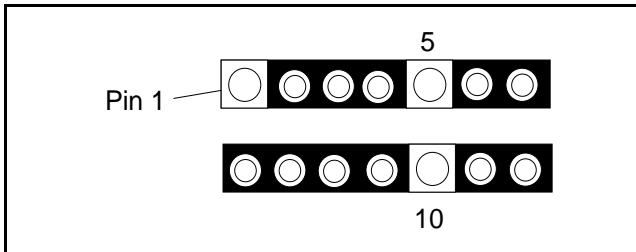
# STANDARD NOTES FOR SERVICING

## Circuit Board Indications

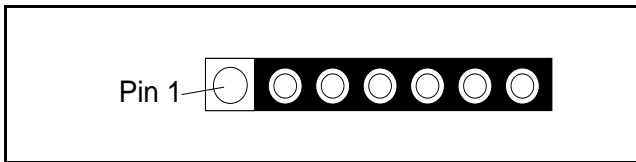
- a. The output pin of the 3 pin Regulator ICs is indicated as shown.



- b. For other ICs, pin 1 and every fifth pin are indicated as shown.

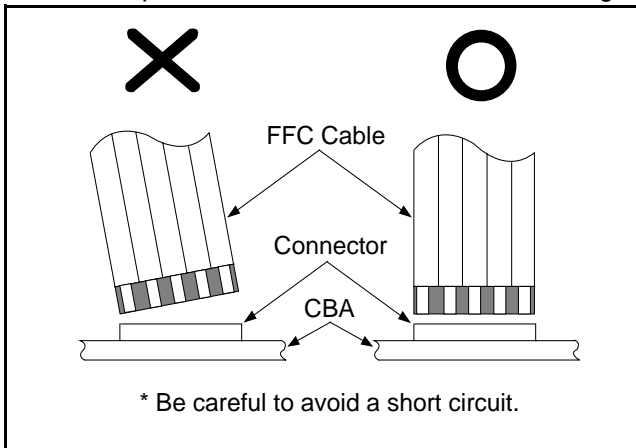


- c. The 1st pin of every male connector is indicated as shown.



## Instructions for Connectors

- When you connect or disconnect the FFC (Flexible Foil Connector) cable, be sure to first disconnect the AC cord.
- FFC (Flexible Foil Connector) cable should be inserted parallel into the connector, not at an angle.

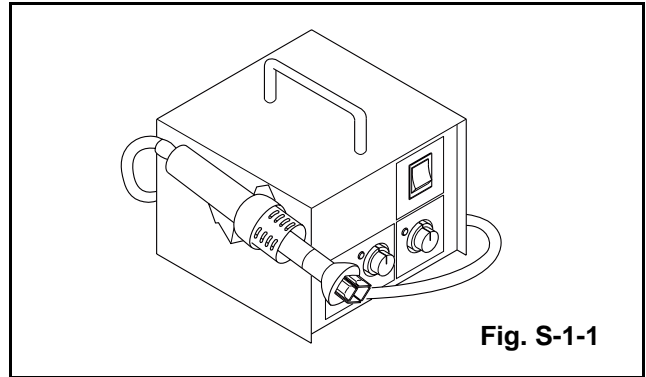


## How to Remove / Install Flat Pack-IC

### 1. Removal

**With Hot-Air Flat Pack-IC Desoldering Machine:**

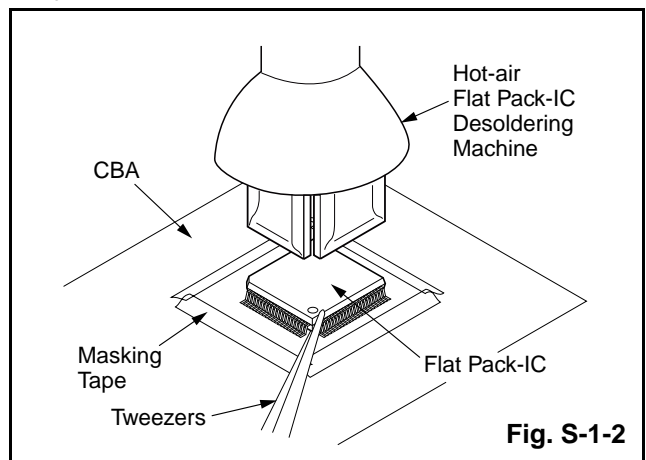
- (1) Prepare the hot-air flat pack-IC desoldering machine, then apply hot air to the Flat Pack-IC (about 5 to 6 seconds). (Fig. S-1-1)



- (2) Remove the flat pack-IC with tweezers while applying the hot air.
- (3) Bottom of the flat pack-IC is fixed with glue to the CBA; when removing entire flat pack-IC, first apply soldering iron to center of the flat pack-IC and heat up. Then remove (glue will be melted). (Fig. S-1-6)
- (4) Release the flat pack-IC from the CBA using tweezers. (Fig. S-1-6)

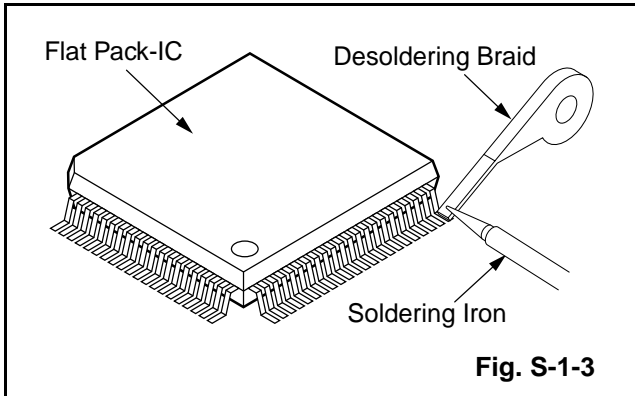
### Caution:

- Do not supply hot air to the chip parts around the flat pack-IC for over 6 seconds because damage to the chip parts may occur. Put masking tape around the flat pack-IC to protect other parts from damage. (Fig. S-1-2)
- The flat pack-IC on the CBA is affixed with glue, so be careful not to break or damage the foil of each pin or the solder lands under the IC when removing it.

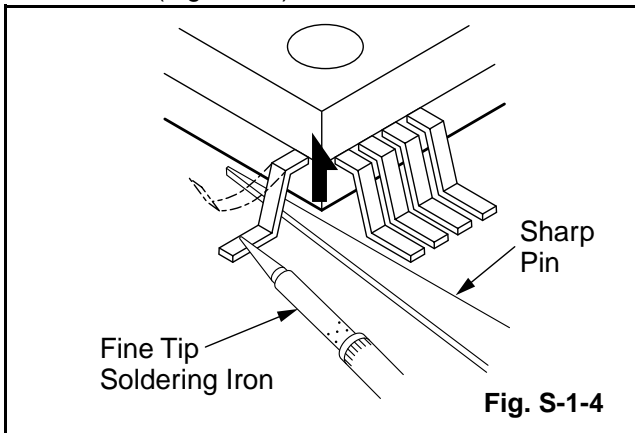


**With Soldering Iron:**

- (1) Using desoldering braid, remove the solder from all pins of the flat pack-IC. When you use solder flux which is applied to all pins of the flat pack-IC, you can remove it easily. (Fig. S-1-3)



- (2) Lift each lead of the flat pack-IC upward one by one, using a sharp pin or wire to which solder will not adhere (iron wire). When heating the pins, use a fine tip soldering iron or a hot air desoldering machine. (Fig. S-1-4)



- (3) Bottom of the flat pack-IC is fixed with glue to the CBA; when removing entire flat pack-IC, first apply soldering iron to center of the flat pack-IC and heat up. Then remove (glue will be melted). (Fig. S-1-6)
- (4) Release the flat pack-IC from the CBA using tweezers. (Fig. S-1-6)

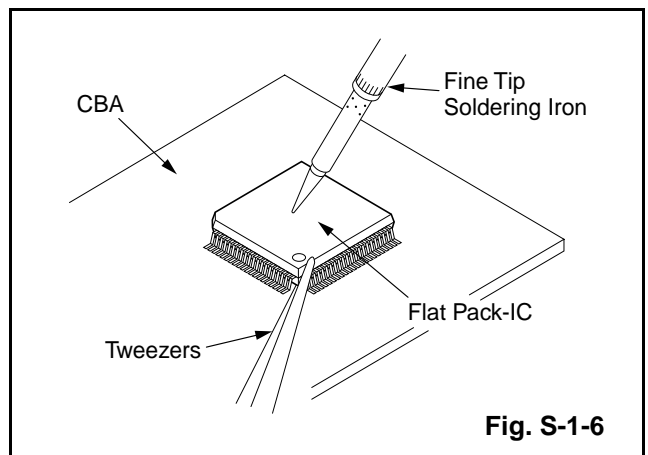
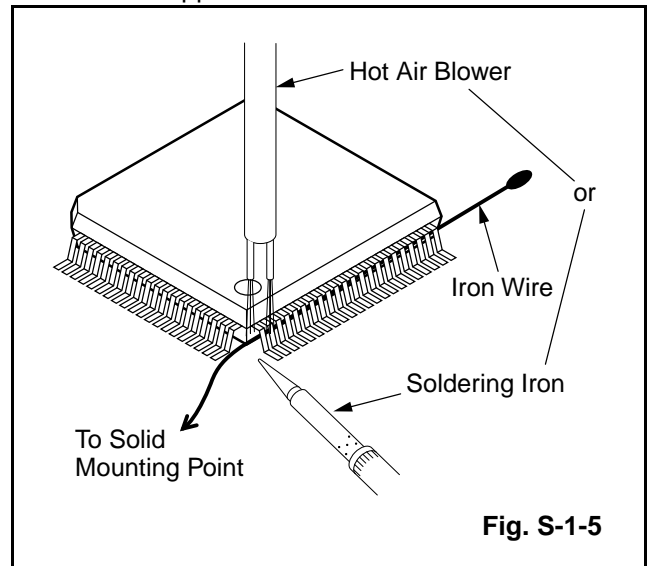
**With Iron Wire:**

- (1) Using desoldering braid, remove the solder from all pins of the flat pack-IC. When you use solder flux which is applied to all pins of the flat pack-IC, you can remove it easily. (Fig. S-1-3)
- (2) Affix the wire to a workbench or solid mounting point, as shown in Fig. S-1-5.
- (3) While heating the pins using a fine tip soldering iron or hot air blower, pull up the wire as the solder melts so as to lift the IC leads from the CBA contact pads as shown in Fig. S-1-5

- (4) Bottom of the flat pack-IC is fixed with glue to the CBA; when removing entire flat pack-IC, first apply soldering iron to center of the flat pack-IC and heat up. Then remove (glue will be melted). (Fig. S-1-6)
- (5) Release the flat pack-IC from the CBA using tweezers. (Fig. S-1-6)

**Note:**

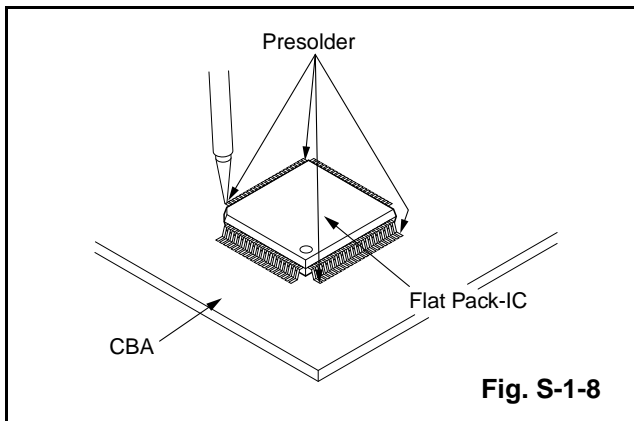
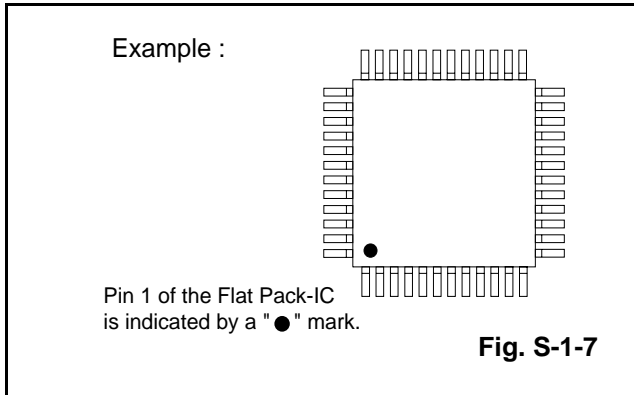
When using a soldering iron, care must be taken to ensure that the flat pack-IC is not being held by glue. When the flat pack-IC is removed from the CBA, handle it gently because it may be damaged if force is applied.





## 2. Installation

- (1) Using desoldering braid, remove the solder from the foil of each pin of the flat pack-IC on the CBA so you can install a replacement flat pack-IC more easily.
- (2) The "●" mark on the flat pack-IC indicates pin 1. (See Fig. S-1-7.) Be sure this mark matches the 1 on the PCB when positioning for installation. Then presolder the four corners of the flat pack-IC. (See Fig. S-1-8.)
- (3) Solder all pins of the flat pack-IC. Be sure that none of the pins have solder bridges.



## Instructions for Handling Semi-conductors

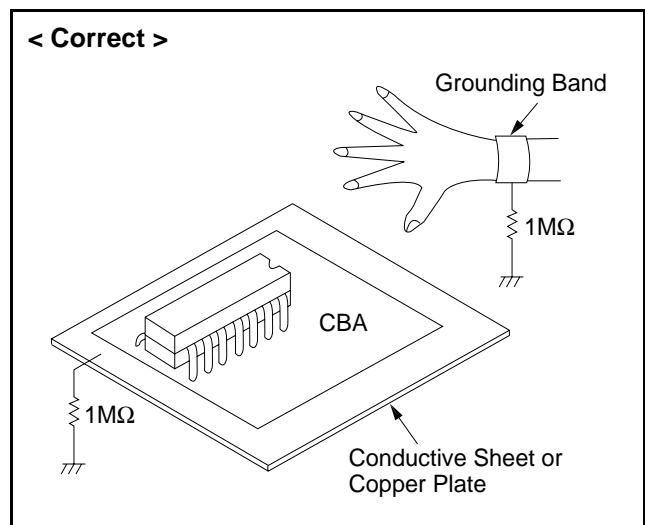
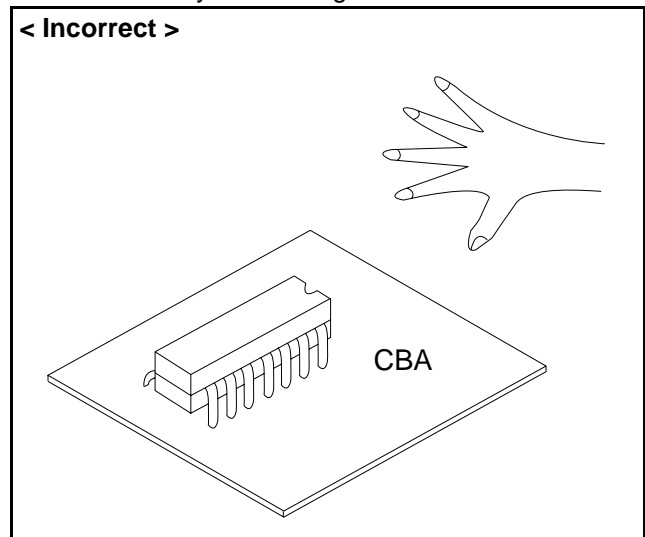
Electrostatic breakdown of the semi-conductors may occur due to a potential difference caused by electrostatic charge during unpacking or repair work.

### 1. Ground for Human Body

Be sure to wear a grounding band ( $1M\Omega$ ) that is properly grounded to remove any static electricity that may be charged on the body.

### 2. Ground for Workbench

- (1) Be sure to place a conductive sheet or copper plate with proper grounding ( $1M\Omega$ ) on the workbench or other surface, where the semi-conductors are to be placed. Because the static electricity charge on clothing will not escape through the body grounding band, be careful to avoid contacting semi-conductors with your clothing.



# PREPARATION FOR SERVICING

## How to Enter the Service Mode

### About Optical Sensors

#### **Caution:**

An optical sensor system is used for the Tape Start and End Sensors on this equipment. Carefully read and follow the instructions below. Otherwise the unit may operate erratically.

#### **What to do for preparation**

Insert a tape into the Deck Mechanism Assembly and press the PLAY button. The tape will be loaded into the Deck Mechanism Assembly. Make sure the power is on, TP501 (SENSOR INHIBITION) to GND. This will stop the function of Tape Start Sensor, Tape End Sensor and Reel Sensors. (If these TPs are connected before plugging in the unit, the function of the sensors will stay valid.) See Fig. 1.

**Note:** Because the Tape End Sensors are inactive, do not run a tape all the way to the start or the end of the tape to avoid tape damage.

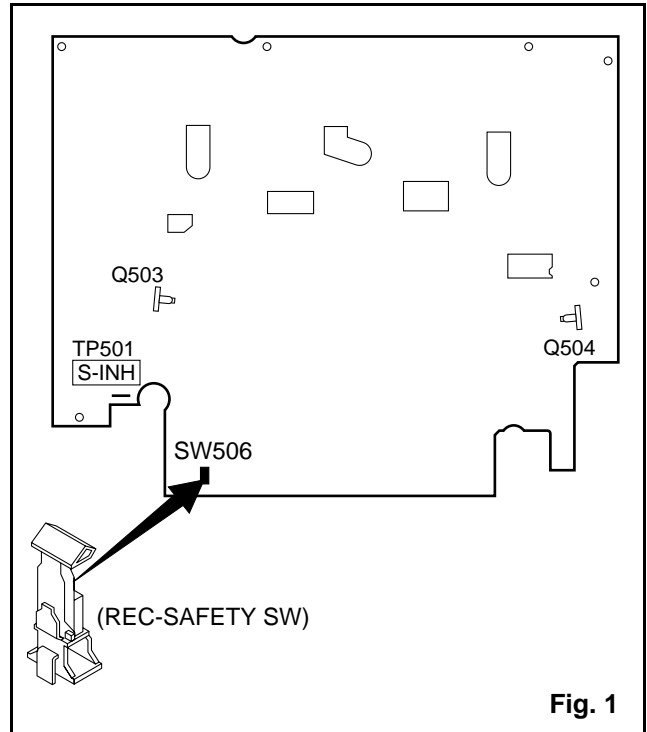
### About REC-Safety Switch

#### **Caution:**

The REC-Safety Switch is directly mounted on the Main CBA. When the Deck Mechanism Assembly is removed from the Main CBA for servicing, this switch does not work automatically.

#### **What to do for preparation**

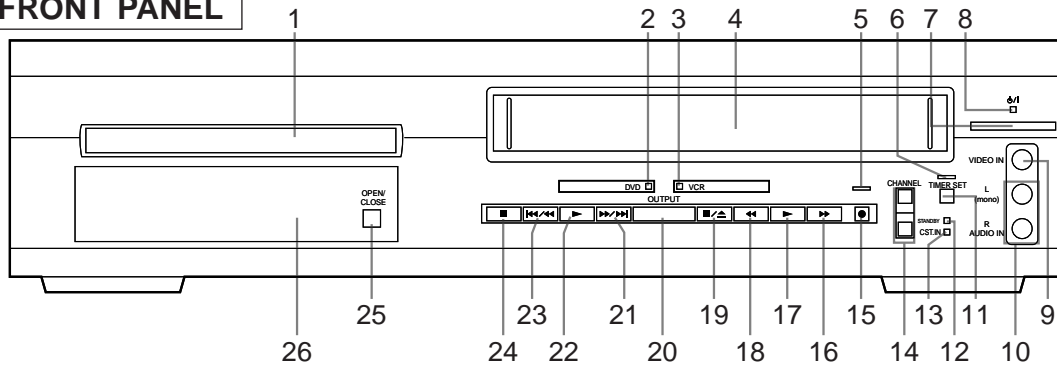
In order to record, press the Rec button while pushing REC-SAFETY SW on the Main CBA. See Fig. 1.



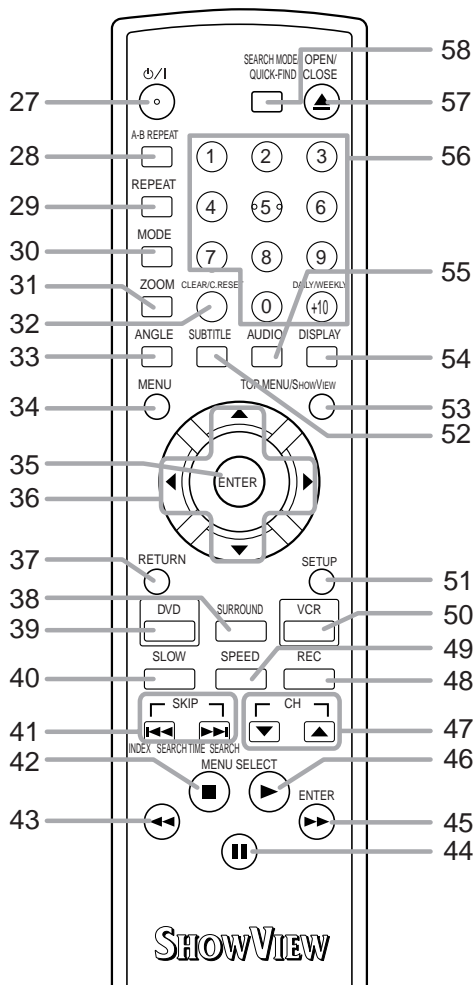
# OPERATING CONTROLS AND FUNCTIONS

[ DV-PF2E ]

## FRONT PANEL



## REMOTE CONTROL



VCR operation Buttons : Blue  
 DVD operation Buttons : Green  
 Common operation Buttons : White

1. **Disc loading tray**
2. **DVD OUTPUT Light (Green)**  
 This light appears when the DVD output mode is selected. You can only watch DVDs when the green DVD

OUTPUT Light is on. To make the green DVD OUTPUT light come on, press the DVD Button on the remote control or the OUTPUT Button on the front panel.

3. **VCR OUTPUT Light (Green)**  
 This light appears when the VCR output mode is selected. You can only watch tapes when the green VCR OUTPUT light is on. To make the green VCR OUTPUT light come on, the VCR Button on the remote control or the OUTPUT Button on the front panel.

### 4. CASSETTE COMPARTMENT

5. **REC/OTR Light**  
 Lights up during recording.

6. **TIMER SET Light**  
 This light glows when the DVD/VCR is in standby mode or off for a timer recording or during a One-Touch Recording. It flashes if the TIMER SET Button is pressed for a timer recording, but there is no tape in the DVD/VCR. It flashes when all timer recordings or One Touch Recording are finished.

### 7. $\phi/1$ (Standby/Power ON) Button

Press to turn the power on and off.

### 8. $\phi/1$ (Standby/Power ON) Light

Lights up when the power is on.

### 9. VIDEO In Jack

Connect a video cable coming from the video out jack of a camcorder, another VCR, or a video source (laser disc player, etc.) here.

### 10. AUDIO In Jacks

Connect audio cables coming from the audio out jacks of a camcorder, another VCR, or an audio source here.

### 11. TIMER SET Button

Press to put the DVD/VCR into standby mode for a timer recording.

### 12. STANDBY Light

Lights up when the DVD/VCR is plugged in.

### 13. CST. IN Light

Lights up when a cassette is in the DVD/VCR.

### 14. CHANNEL Buttons

In VCR mode, press to change TV channels on the DVD/VCR; press to adjust the tracking during normal or slow motion playback; press to remove vertical jitter in a Still picture.

### 15. REC/OTR Button (VCR)

Press once to start a recording. Press repeatedly to start an One Touch Recording Timer.

16. **▶▶(F.FWD) Button (VCR)**  
Press to rapidly advance the tape, or view the picture rapidly in forward during playback. (Forward Search). When setting programme (For example: setting clock or timer programme), press to determine your selection and proceed to the next step you want to input. Press to determine the setting modes from the on screen menu.
17. **▶(PLAY) Button (VCR)**  
Press to begin playback. Press to enter digits when setting programme (For example: setting clock or timer programme). Press to select the setting modes from the on screen menu.
18. **◀◀(REW) Button (VCR)**  
Press to rewind the tape, or to view the picture rapidly in reverse during the playback mode (Rewind Search). Press to cancel a setting of timer programme. Press to correct digits when setting programme (For example: setting clock or timer programme).
19. **■/▲(STOP/EJECT) Button (VCR)**
  - **EJECT Button**  
Press to remove the tape from the DVD/VCR.
  - **STOP Button**  
Press to stop the tape motion. Press to enter digits when setting programme (For example: setting clock or timer programme). Press to select the setting modes from the on screen menu.
20. **OUTPUT Button**  
Press to select DVD mode or VCR mode.
  - You can switch the output mode of the DVD/VCR either by pressing the OUTPUT Button on the front panel, or by pressing the DVD or VCR Button on the remote control. However, **pressing only the OUTPUT Button on the front panel does not switch the output mode of the remote control. If you want to use the remote control, you always need to select the correct output mode on the remote control, too.**
21. **▶▶/▶▶(SKIP) Button (DVD)**  
Plays back from the beginning of the next chapter or track. Hold down to fast forward playback.
22. **▶(PLAY) Button (DVD)**  
Starts playback of the disc contents.
23. **◀◀/◀◀(SKIP) Button (DVD)**  
Plays back from the beginning of the current chapter or track. Hold down to fast reverse playback.
24. **■(STOP) Button (DVD)**  
Stops operation of the disc.
25. **OPEN/CLOSE Button**  
Press to insert discs into or remove them from the tray.
26. **Display, Remote Sensor Window**
27. **⏻/⏻ (Standby/Power ON) Button**  
Press to turn the power on and off.
28. **A-B REPEAT Button**  
Repeats playback of a selected section.
29. **REPEAT Button**  
Repeats playback of the current disc, title, chapter or track.
30. **MODE Button**  
Activates programme playback or random playback mode when playing CDs or MP3. Sets Black level or SRS TruSurround.
31. **ZOOM Button**  
Enlarges part of a DVD-reproduced image.
32. **CLEAR/C.RESET Button**
  - **DVD mode**  
Press to reset the setting.
  - **VCR mode**  
Press to reset the counter.
33. **ANGLE Button**  
Press to change the camera angle to see the sequence being played back from a different angle.
34. **MENU Button**
  - **DVD mode**  
Press to display the menu of the Disc.
  - **VCR mode**  
Press to access the VCR menu.
35. **ENTER Button**  
Press to accept a setting.
36. **Arrow Buttons (▼/▲/◀/▶)**  
Use when making settings while watching the display on a TV screen.
37. **RETURN Button**  
Returns to the previous operation.
38. **SURROUND Button**  
Press to enjoy stereophonic sound system when you playback Dolby Digital and PCM 48kHz sound.
39. **DVD Button**  
Press to select DVD mode for the remote control.
  - You can switch the output mode of the DVD/VCR either by pressing the OUTPUT Button on the front panel, or by pressing the DVD or the VCR Button on the remote control. However, **pressing only the OUTPUT Button on the front panel does not switch the output mode of the remote control. If you want to use the remote control, you always need to select the correct output mode on the remote control, too.**
40. **SLOW Button (VCR)**  
During tape playback, press to view the video tape in slow motion. Press the ▶ Button to resume normal playback. This Button does not affect DVD playback.
41. **SKIP Buttons (◀◀/▶▶) (DVD)**  
Press to skip Chapters or Tracks.  
**INDEX SEARCH Button (◀◀) (VCR)**  
Press to perform Index Search.  
**TIME SEARCH Button (▶▶) (VCR)**  
Press to perform Time Search.
42. **■(MENU SELECT/STOP) Button**
  - **DVD mode**  
Stops operation of the disc.
  - **VCR mode**  
Press to stop the tape motion. Press to enter digits when setting programme (For example: setting clock or timer programme). Press to select the setting modes from the on screen menu.
43. **◀◀(REV/REW) Button**
  - **DVD mode**  
Press to view the DVD picture in fast reverse motion or to reverse playback of an Audio CD.
  - **VCR mode**  
Press to rewind the tape, or to view the picture rapidly in reverse during the playback mode (Rewind Search). Press to cancel a setting of timer programme. Press to correct digits when setting programme (For example: setting clock or timer programme).

#### 44. **II(PAUSE/STILL) Button**

##### ● **DVD mode**

Press to pause Disc playback. Press repeatedly to advance the DVD picture step by step (or one frame at a time).

##### ● **VCR mode**

While recording, press to temporarily stop the recording (pause). Press a second time to resume normal recording. You can not pause a One Touch Recording. Or, press during tape playback to freeze the picture. Press to advance the picture one frame at a time during still mode.

#### 45. **▶▶(ENTER/FWD/F.FWD) Button**

##### ● **DVD mode**

Press to fast forward the Disc. Press the **II** Button, then press this Button to begin slow motion playback. Press this Button repeatedly to change the forward speed of slow motion.

##### ● **VCR mode**

Press to rapidly advance the tape, or view the picture rapidly in forward during playback (Forward Search). When setting programme (For example: setting clock or timer programme), press to determine your selection and proceed to the next step you want to input. Press to determine the setting modes from the on screen menu.

#### 46. **▶(MENU SELECT/PLAY) Button**

##### ● **DVD mode**

Press to begin playback.

##### ● **VCR mode**

Press to begin playback. Press to enter digits when setting programme (For example: setting clock or timer programme). Press to select the setting modes from the on screen menu.

#### 47. **CH Buttons (▼/▲) (VCR)**

In VCR mode, press to change TV channels on the DVD/VCR; press to adjust the tracking during normal or slow motion playback; press to remove vertical jitter in a Still picture.

#### 48. **REC Button (VCR)**

Press once to start a recording.

#### 49. **SPEED Button (VCR)**

Press to select the VCR's recording speed (SP or LP).

#### 50. **VCR Button**

Press to select VCR mode for the remote control.

● You can switch the output mode of the DVD/VCR either by pressing the **OUTPUT** Button on the front panel, or by pressing the **DVD** or the **VCR** Button on the remote control. However, **pressing only the OUTPUT Button on the front panel does not switch the output mode of the remote control. If you want to use the remote control, you always need to select the correct output mode on the remote control, too.**

#### 51. **SETUP Button**

Press to enter the setup mode.

#### 52. **SUBTITLE Button**

Press to select the desired subtitle language.

#### 53. **TOP MENU/SHOWVIEW Button**

##### ● **DVD mode**

Press to bring up the Top Menu on a disc.

##### ● **VCR mode**

Press to programme timer recording with the **SHOWVIEW** system.

#### 54. **DISPLAY Button**

##### ● **DVD mode**

Press to access or remove the display screen during DVD or Audio CD playback.

##### ● **VCR mode**

Press to access or remove the VCR's on-screen status display.

#### 55. **AUDIO Button**

##### ● **DVD mode**

Press to select a desired audio language or sound mode.

##### ● **VCR mode**

Press to select a desired sound mode.

#### 56. **Number Buttons**

##### ● **DVD mode**

Press to directly select a Track (Audio CD) for playback.

Press to programme Tracks (Audio CD) for playback.

##### **+10 Button:**

When searching a **TITLE**, a **CHAPTER**, or a **TRACK**, use this button to enter numbers 10 and above. For example when entering '15', press this button first, then press '5'.

##### ● **VCR mode**

Press to select TV channels on the DVD/VCR.

To select channels, enter channel numbers as a two-digit number for the quickest results. For example, to select channel 6, press 0 then 6.

##### **DAILY/WEEKLY Button:**

Press to select once, daily, everyday, or weekly when you programme the automatic timer recording using the **SHOWVIEW** system.

#### 57. **OPEN/CLOSE Button (▲)**

Press to insert discs into or remove them from the tray.

#### 58. **SEARCH MODE/QUICK-FIND Button**

##### ● **DVD mode**

Press to access or remove the Search display, which allows you to go directly to a specific Title/Chapter/Track/Time.

##### ● **VCR mode**

Press to use Quick-Find mode.

## DISPLAY

Stays on when the A-B repeat function is on.

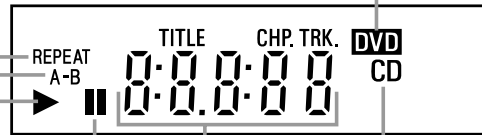
Stays on when the repeat function is on.

Lights up when a DVD is inserted on the tray.

Lights up when the inserted disc comes to a pause.

Stays on when the inserted disc is being played back.

Displays how long a current title or track has been played back. When a chapter or track has switched, the number of a new title, chapter or track is displayed.

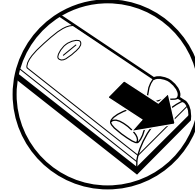


## DISPLAYS DURING OPERATION

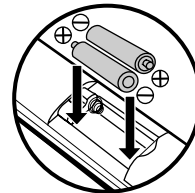
	Power on
	No disc inserted
	Tray open
	Tray closed
	Loading the Disc
	Power off

## LOADING THE BATTERIES

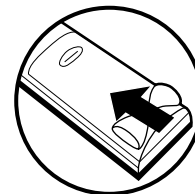
1. Open the battery compartment cover.



2. Insert two AA batteries, with each one oriented correctly.



3. Close the cover.

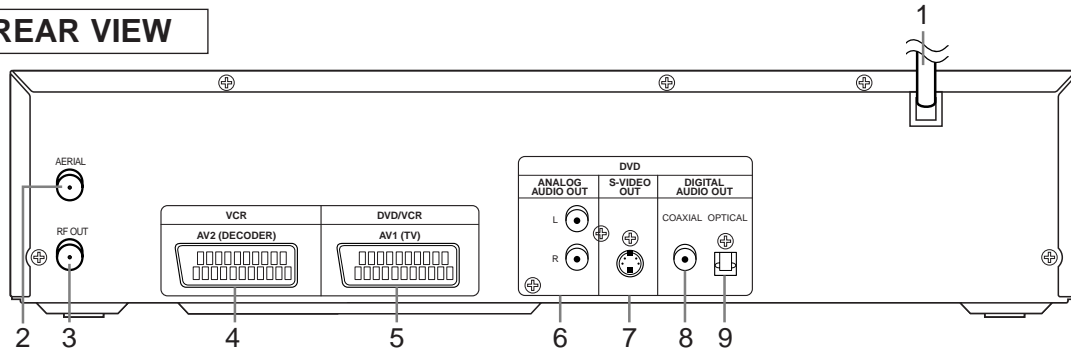


### Notes

- Do not mix alkaline and manganese batteries.
- Do not mix old and new batteries.

## DESCRIPTION-REAR PANEL

### REAR VIEW



**1. AC POWER CORD**

Connect to a standard AC outlet to supply power to the DVD/VCR.

**2. AERIAL Jack**

Connect your antenna, Cable Box, or Direct Broadcast System.

**3. RF OUT Jack**

Use the supplied RF coaxial cable to connect this jack to the ANTENNA IN Jack on your TV.

**4. AV2 (DECODER) Socket**

Connect 21-Pin scart cable here and to the 21-Pin scart jack of a decoder.

**5. AV1 (TV) Socket**

Connect 21-Pin scart cable here and to the 21-Pin scart jack of a TV.

**6. ANALOG AUDIO OUT Jacks (DVD only)**

Connect the supplied audio cables here and to the Audio In jacks of a television or other audio equipment.

**7. S-VIDEO OUT Jack (DVD only)**

Connect an optional S-Video cable here and to the S-Video In jack of a television.

**8. DIGITAL COAXIAL AUDIO OUT Jack (DVD only)**

Connect an optional coaxial digital audio cable here and to the Coaxial Digital Audio In jack of a decoder or audio receiver.

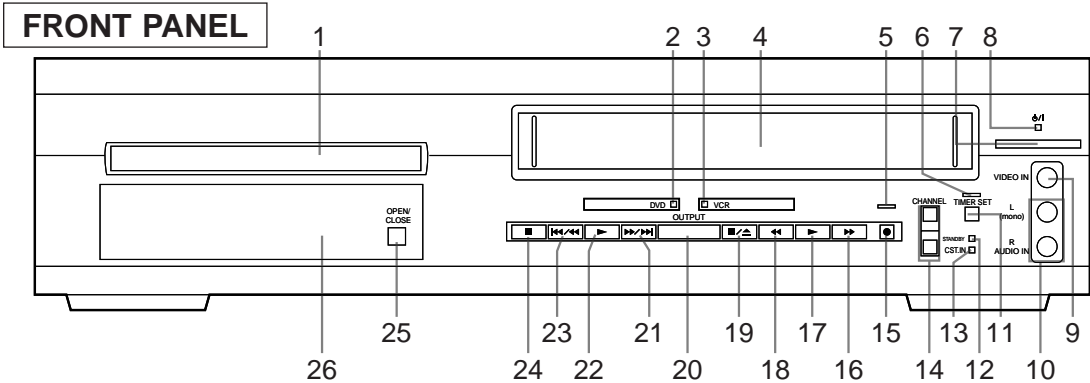
**9. DIGITAL OPTICAL AUDIO OUT Jack (DVD only)**

Connect an optional optical digital audio cable here and to the Optical Digital Audio In jack of a decoder or audio receiver.

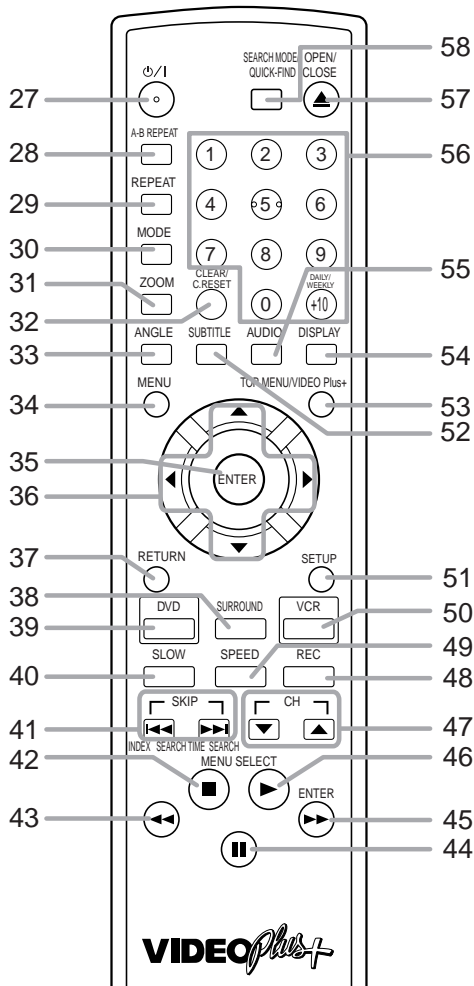
Manufactured under license from Dolby Laboratories. "Dolby" and the double-D symbol are trademarks of Dolby Laboratories.

"DTS" and "DTS Digital Out" are trademarks of Digital Theater Systems, Inc.

# [ DV-PF2E(UK) ]



## REMOTE CONTROL



VCR operation Buttons : Blue  
 DVD operation Buttons : Green  
 Common operation Buttons : White

1. Disc loading tray
2. DVD OUTPUT Light (Green)  
 This light appears when the DVD output mode is selected. You can only watch DVDs when the green DVD

- OUTPUT Light is on. To make the green DVD OUTPUT light come on, press the DVD Button on the remote control or the OUTPUT Button on the front panel.
3. VCR OUTPUT Light (Green)  
 This light appears when the VCR output mode is selected. You can only watch tapes when the green VCR OUTPUT light is on. To make the green VCR OUTPUT light come on, the VCR Button on the remote control or the OUTPUT Button on the front panel.
4. CASSETTE COMPARTMENT
5. REC/OTR Light  
 Lights up during recording.
6. TIMER SET Light  
 This light glows when the DVD/VCR is in standby mode or off for a timer recording or during a One-Touch Recording. It flashes if the TIMER SET Button is pressed for a timer recording, but there is no tape in the DVD/VCR. It flashes when all timer recordings or One Touch Recording are finished.
7.  $\phi/1$  (Standby/Power ON) Button  
 Press to turn the power on and off.
8.  $\phi/1$  (Standby/Power ON) Light  
 Lights up when the power is on.
9. VIDEO In Jack  
 Connect a video cable coming from the video out jack of a camcorder, another VCR, or a video source (laser disc player, etc.) here.
10. AUDIO In Jacks  
 Connect audio cables coming from the audio out jacks of a camcorder, another VCR, or an audio source here.
11. TIMER SET Button  
 Press to put the DVD/VCR into standby mode for a timer recording.
12. STANDBY Light  
 Lights up when the DVD/VCR is plugged in.
13. CST. IN Light  
 Lights up when a cassette is in the DVD/VCR.
14. CHANNEL Buttons  
 In VCR mode, press to change TV channels on the DVD/VCR; press to adjust the tracking during normal or slow motion playback; press to remove vertical jitter in a Still picture.
15. REC/OTR Button (VCR)  
 Press once to start a recording. Press repeatedly to start an One Touch Recording Timer.



16. **▶▶(F.FWD) Button (VCR)**  
Press to rapidly advance the tape, or view the picture rapidly in forward during playback. (Forward Search). When setting programme (For example: setting clock or timer programme), press to determine your selection and proceed to the next step you want to input. Press to determine the setting modes from the on screen menu.
17. **▶(PLAY) Button (VCR)**  
Press to begin playback. Press to enter digits when setting programme (For example: setting clock or timer programme). Press to select the setting modes from the on screen menu.
18. **◀◀(REW) Button (VCR)**  
Press to rewind the tape, or to view the picture rapidly in reverse during the playback mode (Rewind Search). Press to cancel a setting of timer programme. Press to correct digits when setting programme (For example: setting clock or timer programme).
19. **■/▲(STOP/EJECT) Button (VCR)**
  - **EJECT Button**  
Press to remove the tape from the DVD/VCR.
  - **STOP Button**  
Press to stop the tape motion. Press to enter digits when setting programme (For example: setting clock or timer programme). Press to select the setting modes from the on screen menu.
20. **OUTPUT Button**  
Press to select DVD mode or VCR mode.
  - You can switch the output mode of the DVD/VCR either by pressing the OUTPUT Button on the front panel, or by pressing the DVD or VCR Button on the remote control. However, **pressing only the OUTPUT Button on the front panel does not switch the output mode of the remote control. If you want to use the remote control, you always need to select the correct output mode on the remote control, too.**
21. **▶▶/▶▶(SKIP) Button (DVD)**  
Plays back from the beginning of the next chapter or track. Hold down to fast forward playback.
22. **▶(PLAY) Button (DVD)**  
Starts playback of the disc contents.
23. **◀◀/◀◀(SKIP) Button (DVD)**  
Plays back from the beginning of the current chapter or track. Hold down to fast reverse playback.
24. **■(STOP) Button (DVD)**  
Stops operation of the disc.
25. **OPEN/CLOSE Button**  
Press to insert discs into or remove them from the tray.
26. **Display, Remote Sensor Window**
27. **⏻/⏻(Standby/Power ON) Button**  
Press to turn the power on and off.
28. **A-B REPEAT Button**  
Repeats playback of a selected section.
29. **REPEAT Button**  
Repeats playback of the current disc, title, chapter or track.
30. **MODE Button**  
Activates programme playback or random playback mode when playing CDs or MP3. Sets Black level or SRS TruSurround.
31. **ZOOM Button**  
Enlarges part of a DVD-reproduced image.
32. **CLEAR/C.RESET Button**
  - **DVD mode**  
Press to reset the setting.
  - **VCR mode**  
Press to reset the counter.
33. **ANGLE Button**  
Press to change the camera angle to see the sequence being played back from a different angle.
34. **MENU Button**
  - **DVD mode**  
Press to display the menu of the Disc.
  - **VCR mode**  
Press to access the VCR menu.
35. **ENTER Button**  
Press to accept a setting.
36. **Arrow Buttons (▼/▲/◀/▶)**  
Use when making settings while watching the display on a TV screen.
37. **RETURN Button**  
Returns to the previous operation.
38. **SURROUND Button**  
Press to enjoy stereophonic sound system when you playback Dolby Digital and PCM 48kHz sound.
39. **DVD Button**  
Press to select DVD mode for the remote control.
  - You can switch the output mode of the DVD/VCR either by pressing the OUTPUT Button on the front panel, or by pressing the DVD or the VCR Button on the remote control. However, **pressing only the OUTPUT Button on the front panel does not switch the output mode of the remote control. If you want to use the remote control, you always need to select the correct output mode on the remote control, too.**
40. **SLOW Button (VCR)**  
During tape playback, press to view the video tape in slow motion. Press the ▶ Button to resume normal playback. This Button does not affect DVD playback.
41. **SKIP Buttons (◀◀/▶▶) (DVD)**  
Press to skip Chapters or Tracks.  
**INDEX SEARCH Button (◀◀) (VCR)**  
Press to perform Index Search.  
**TIME SEARCH Button (▶▶) (VCR)**  
Press to perform Time Search.
42. **■(MENU SELECT/STOP) Button**
  - **DVD mode**  
Stops operation of the disc.
  - **VCR mode**  
Press to stop the tape motion. Press to enter digits when setting programme (For example: setting clock or timer programme). Press to select the setting modes from the on screen menu.
43. **◀◀ (REV/REW) Button**
  - **DVD mode**  
Press to view the DVD picture in fast reverse motion or to reverse playback of an Audio CD.
  - **VCR mode**  
Press to rewind the tape, or to view the picture rapidly in reverse during the playback mode (Rewind Search). Press to cancel a setting of timer programme. Press to correct digits when setting pro-

- gramme (For example: setting clock or timer programme).
44. **II (PAUSE/STILL) Button**
    - **DVD mode**  
Press to pause Disc playback. Press repeatedly to advance the DVD picture step by step (or one frame at a time).
    - **VCR mode**  
While recording, press to temporarily stop the recording (pause). Press a second time to resume normal recording. You can not pause a One Touch Recording. Or, press during tape playback to freeze the picture. Press to advance the picture one frame at a time during still mode.
  45. **▶▶ (ENTER/FWD/F.FWD) Button**
    - **DVD mode**  
Press to fast forward the Disc. Press the **II** Button, then press this Button to begin slow motion playback. Press this Button repeatedly to change the forward speed of slow motion.
    - **VCR mode**  
Press to rapidly advance the tape, or view the picture rapidly in forward during playback (Forward Search). When setting programme (For example: setting clock or timer programme), press to determine your selection and proceed to the next step you want to input. Press to determine the setting modes from the on screen menu. Press to add or delete channel numbers during channel preset.
  46. **▶ (MENU SELECT/PLAY) Button**
    - **DVD mode**  
Press to begin playback.
    - **VCR mode**  
Press to begin playback. Press to enter digits when setting programme (For example: setting clock or timer programme). Press to select the setting modes from the on screen menu.
  47. **CH Buttons (▼/▲) (VCR)**  
In VCR mode, press to change TV channels on the DVD/VCR; press to adjust the tracking during normal or slow motion playback; press to remove vertical jitter in a Still picture.
  48. **REC Button (VCR)**  
Press once to start a recording.
  49. **SPEED Button (VCR)**  
Press to select the VCR's recording speed (SP or LP).
  50. **VCR Button**  
Press to select VCR mode for the remote control.
    - You can switch the output mode of the DVD/VCR either by pressing the **OUTPUT** Button on the front panel, or by pressing the DVD or the VCR Button on the remote control. However, **pressing only the OUTPUT Button on the front panel does not switch the output mode of the remote control. If you want to use the remote control, you always need to select the correct output mode on the remote control, too.**
  51. **SETUP Button**  
Press to enter the setup mode.
  52. **SUBTITLE Button**  
Press to select the desired subtitle language.
  53. **TOP MENU/VIDEO Plus+ Button**
    - **DVD mode**  
Press to bring up the Top Menu on a disc.
    - **VCR mode**  
Press to programme timer recording with the VIDEO Plus+ system.
  54. **DISPLAY Button**
    - **DVD mode**  
Press to access or remove the display screen during DVD or Audio CD playback.
    - **VCR mode**  
Press to access or remove the VCR's on-screen status display.
  55. **AUDIO Button**
    - **DVD mode**  
Press to select a desired audio language or sound mode.
    - **VCR mode**  
Press to select a desired sound mode.
  56. **Number Buttons**
    - **DVD mode**  
Press to directly select a Track (Audio CD) for playback.  
Press to programme Tracks (Audio CD) for playback.
    - +10 Button:**  
When searching a TITLE, a CHAPTER, or a TRACK, use this button to enter numbers 10 and above. For example when entering '15', press this button first, then press '5'.
    - **VCR mode**  
Press to select TV channels on the DVD/VCR. To select channels, enter channel numbers as a two-digit number for the quickest results. For example, to select channel 6, press 0 then 6.
    - DAILY/WEEKLY Button:**  
Press to select once, daily, everyday, or weekly when you programme the automatic timer recording using the VIDEO Plus+ system.
  57. **OPEN/CLOSE Button (▲)**  
Press to insert discs into or remove them from the tray.
  58. **SEARCH MODE/QUICK-FIND Button**
    - **DVD mode**  
Press to access or remove the Search display, which allows you to go directly to a specific Title/Chapter/Track/Time.
    - **VCR mode**  
Press to use Quick-Find mode.

## DISPLAY

Stays on when the A-B repeat function is on.

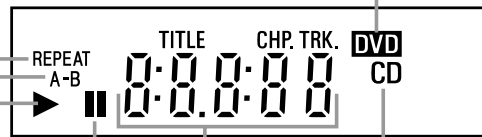
Stays on when the repeat function is on.

Lights up when a DVD is inserted on the tray.

Lights up when the inserted disc comes to a pause.

Stays on when the inserted disc is being played back.

Displays how long a current title or track has been played back. When a chapter or track has switched, the number of a new title, chapter or track is displayed.

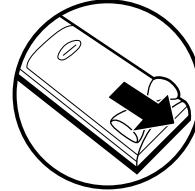


## DISPLAYS DURING OPERATION

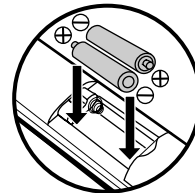
	Power on
	No disc inserted
	Tray open
	Tray closed
	Loading the Disc
	Power off

## LOADING THE BATTERIES

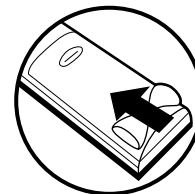
1. Open the battery compartment cover.



2. Insert two AA batteries, with each one oriented correctly.



3. Close the cover.

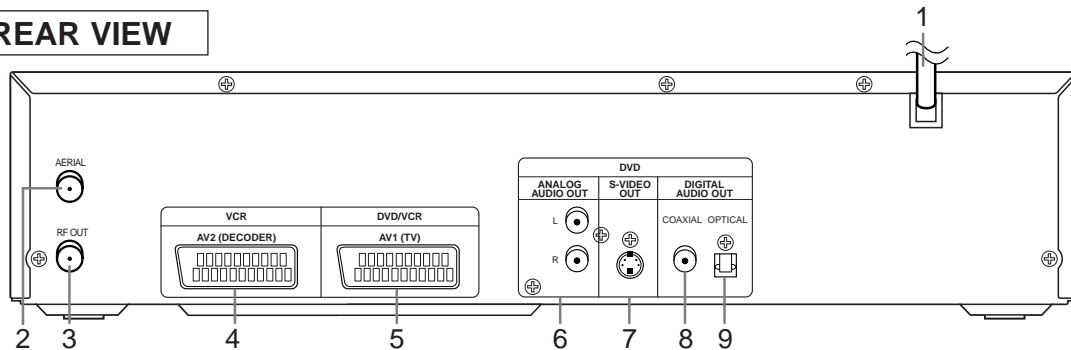


### Notes

- Do not mix alkaline and manganese batteries.
- Do not mix old and new batteries.

## DESCRIPTION-REAR PANEL

### REAR VIEW



1. **AC POWER CORD**  
Connect to a standard AC outlet to supply power to the DVD/VCR.
2. **AERIAL Jack**  
Connect your antenna, Cable Box, or Direct Broadcast System.
3. **RF OUT Jack**  
Use the supplied RF coaxial cable to connect this jack to the ANTENNA IN Jack on your TV.
4. **AV2 (DECODER) Socket**  
Connect 21-Pin scart cable here and to the 21-Pin scart jack of a decoder.
5. **AV1 (TV) Socket**  
Connect 21-Pin scart cable here and to the 21-Pin scart jack of a TV.
6. **ANALOG AUDIO OUT Jacks (DVD only)**  
Connect the supplied audio cables here and to the Audio In jacks of a television or other audio equipment.
7. **S-VIDEO OUT Jack (DVD only)**  
Connect an optional S-Video cable here and to the S-Video In jack of a television.
8. **DIGITAL COAXIAL AUDIO OUT Jack (DVD only)**  
Connect an optional coaxial digital audio cable here and to the Coaxial Digital Audio In jack of a decoder or audio receiver.
9. **DIGITAL OPTICAL AUDIO OUT Jack (DVD only)**  
Connect an optional optical digital audio cable here and to the Optical Digital Audio In jack of a decoder or audio receiver.

Manufactured under license from Dolby Laboratories. "Dolby" and the double-D symbol are trademarks of Dolby Laboratories.

"DTS" and "DTS Digital Out" are trademarks of Digital Theater Systems, Inc.

# FIRMWARE RENEWAL MODE

## HOW TO UPDATE THE FIRMWARE VERSION

1. Turn the power on and remove the disc on the tray.
2. To put the DVD player into version up mode, press [9], [8], [7], [6], and [SEARCH MODE] buttons on the remote control unit in that order. The tray will open automatically.

Fig. a appears on the screen and Fig. b appears on the VFD.

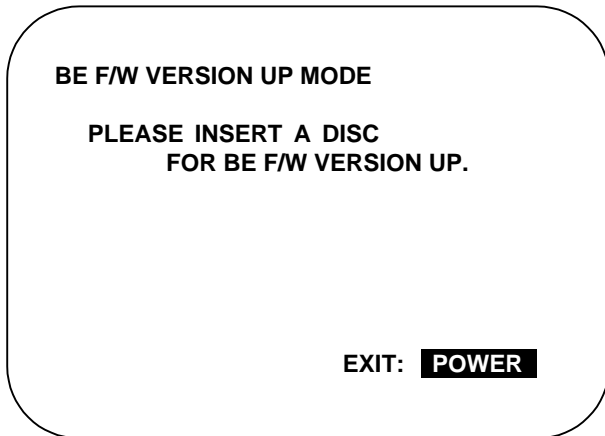


Fig. a Version Up Mode Screen

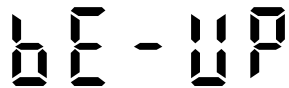


Fig. b VFD in Version Up Mode

The DVD player can also enter the version up mode with the tray open. In this case, Fig. a will be shown on the screen while the tray is open.

3. Load the disc for version up. (For closing the tray, only the "OPEN/CLOSE" button is available.)
4. The DVD player enters the F/W version up mode automatically. Fig. c appears on the screen and Fig. d appears on the VFD.

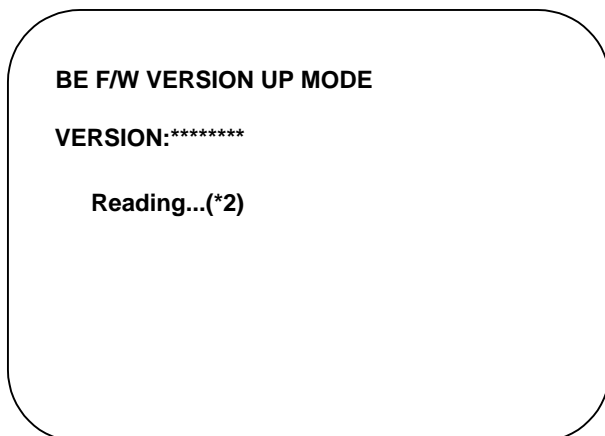


Fig. c Programming Mode Screen



Fig. d VFD in Programming Mode (Example)

The appearance shown in (\*2) of Fig. c is described as follows:

No.	Appearance	State
1	Reading...	Sending files into the memory
2	Erasing...	Erasing previous version data
3	Programming...	Writing new version data

5. After programming is finished, the tray opens automatically. Fig. e appears on the screen and the checksum in (\*3) of Fig. e appears on the VFD. (Fig. f)

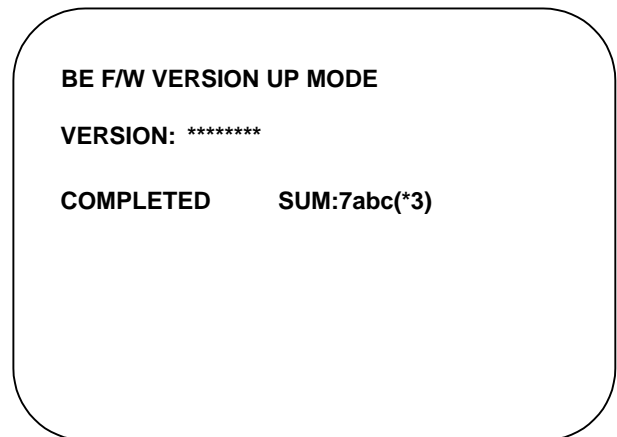


Fig. e Completed Program Mode Screen



Fig. f VFD upon Finishing the Programming Mode (Example)

At this time, no buttons are available.

6. For tray opening, plug the AC cord into the AC outlet.
7. Turn the power on by pressing the power button and the tray will close.

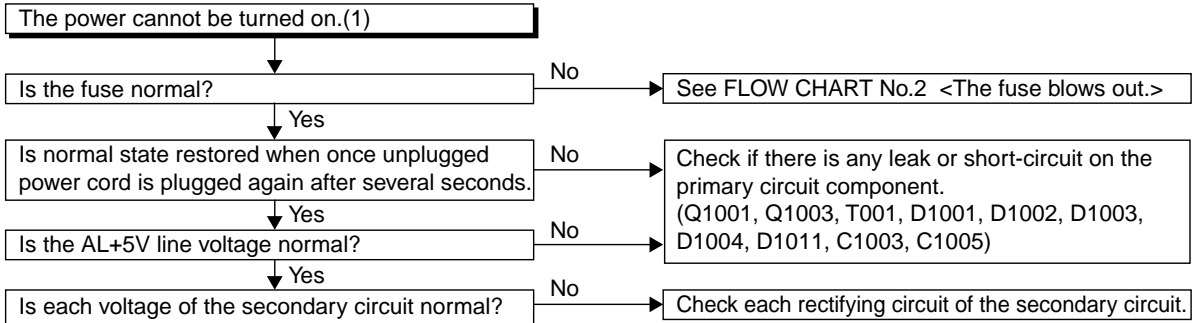
## HOW TO VERIFY THE FIRMWARE VERSION

1. After making sure that no disc is in unit, turn the power on.
2. Press [1], [2], [3], [4], and [DISPLAY] buttons on the remote control unit in that order. The B/E version appears on the VFD, and the F/E and B/E versions appear on TV screen.
3. Turn the power off to reset the unit.

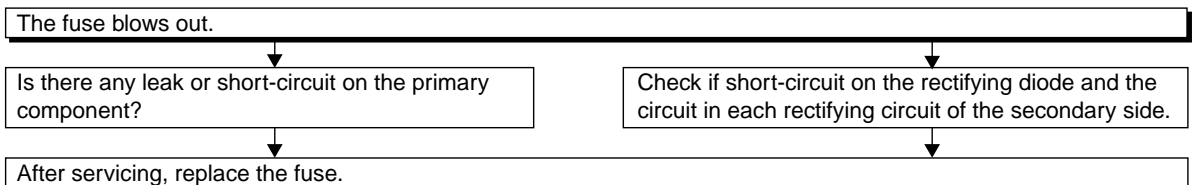
# TROUBLESHOOTING

## [ POWER SUPPLY SECTION ]

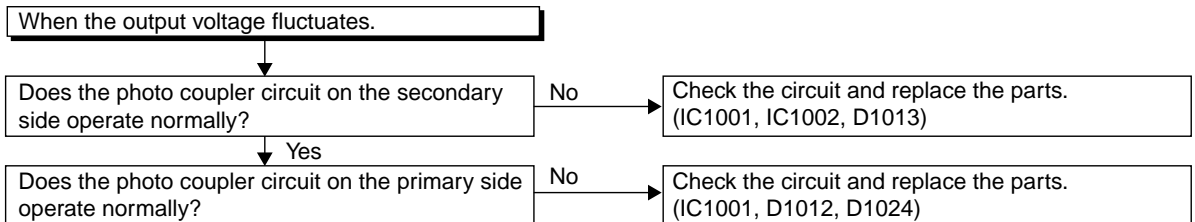
### FLOW CHART NO.1



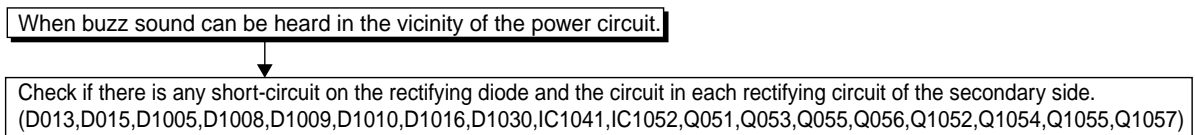
### FLOW CHART NO.2



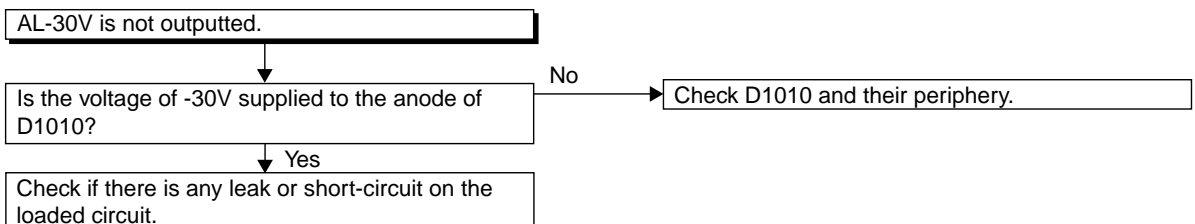
### FLOW CHART NO.3



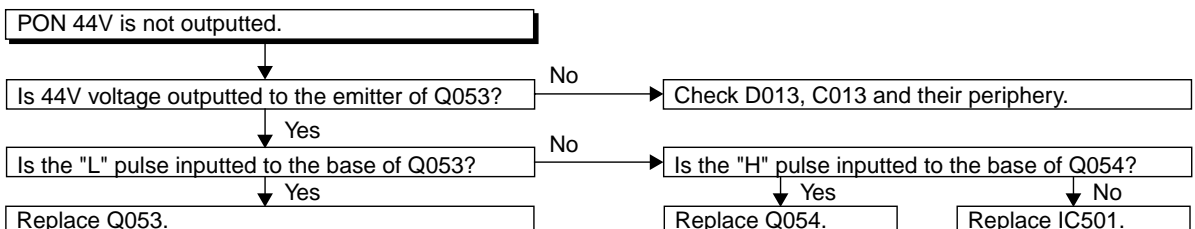
### FLOW CHART NO.4



### FLOW CHART NO.5

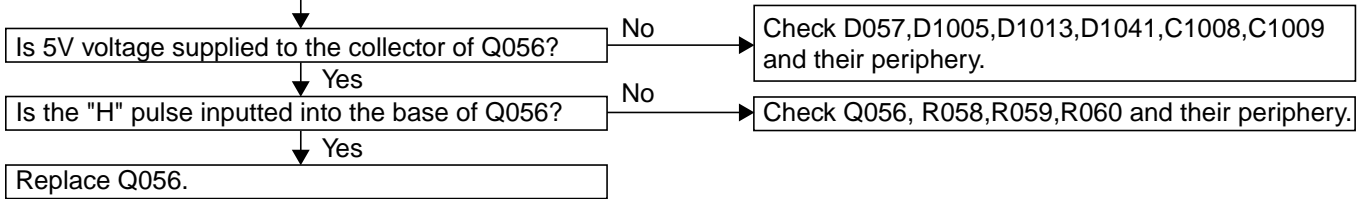


### FLOW CHART NO.6



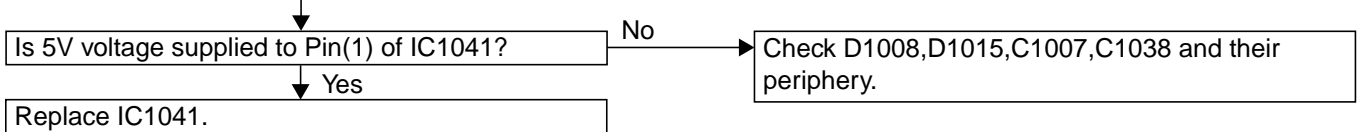
### FLOW CHART NO.7

PON 5V is not outputted. (PON 44V is outputted normally.)



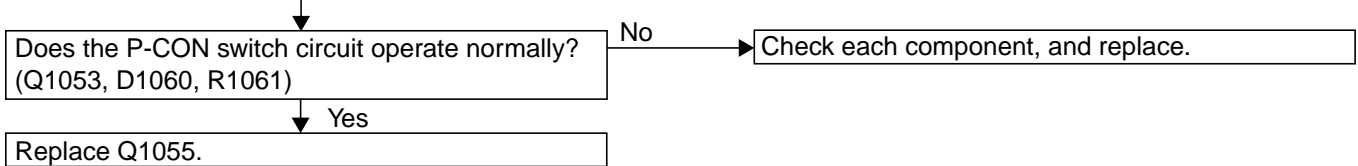
### FLOW CHART NO.8

EV 3.3V is not outputted. (AL 5V is outputted normally.)



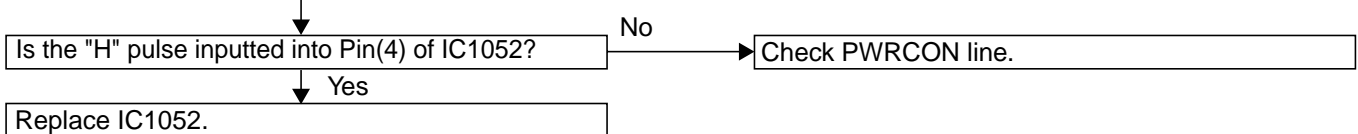
### FLOW CHART NO.9

PON 3.3V is not outputted. (EV 3.3V is outputted normally.)



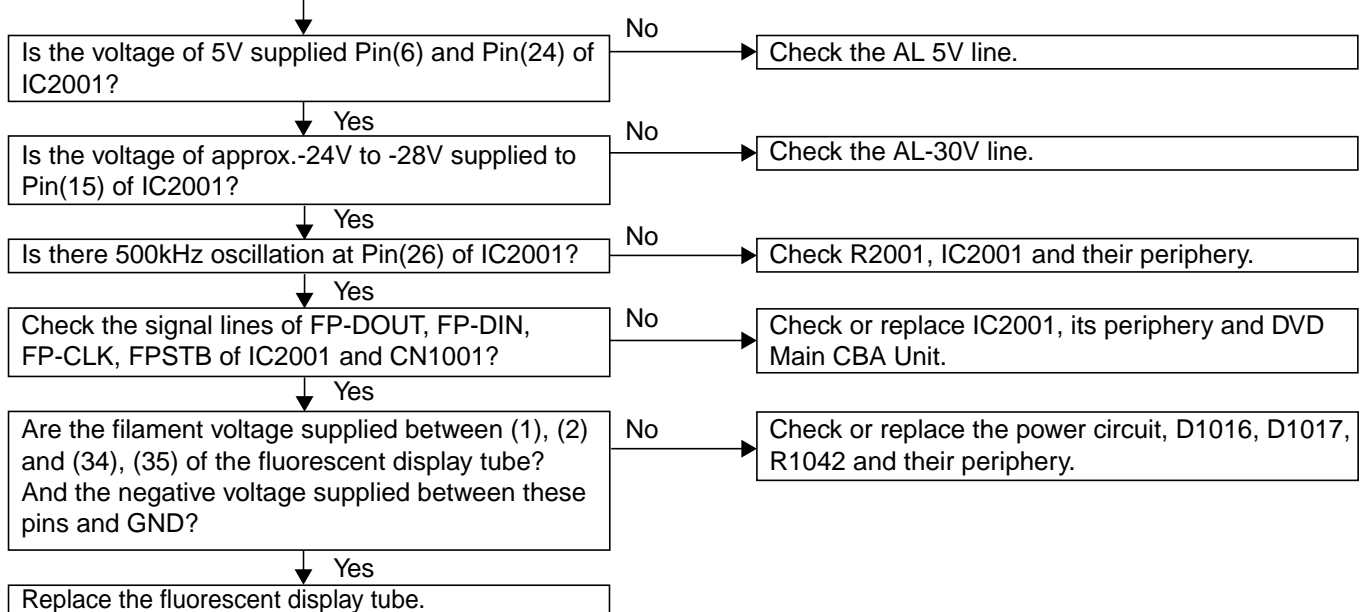
### FLOW CHART NO.10

PON 1.8V is not outputted. (EV 3.3V is outputted normally.)



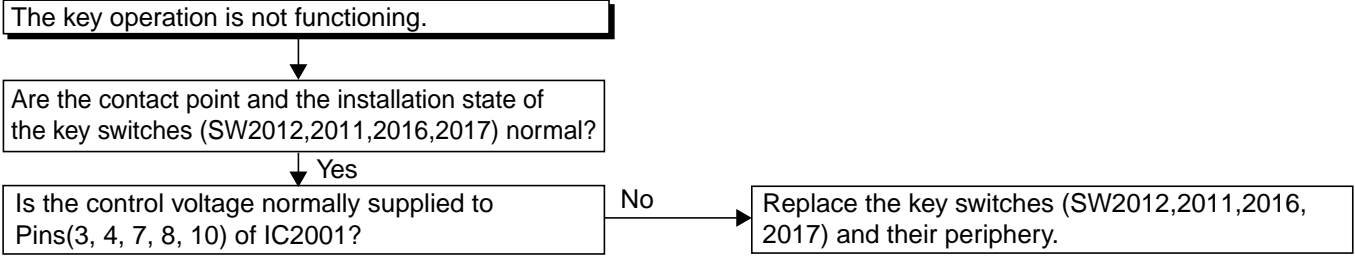
### FLOW CHART NO.11

The fluorescent display tube does not light up.

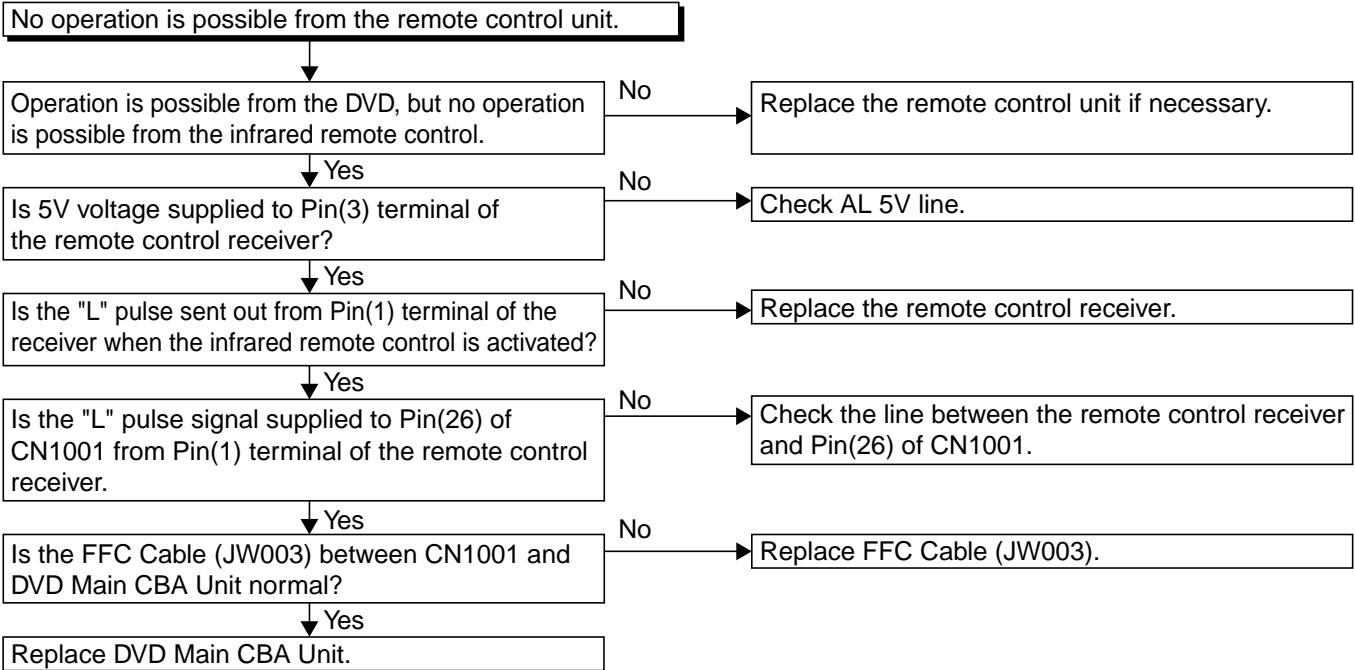


## [ DVD SECTION ]

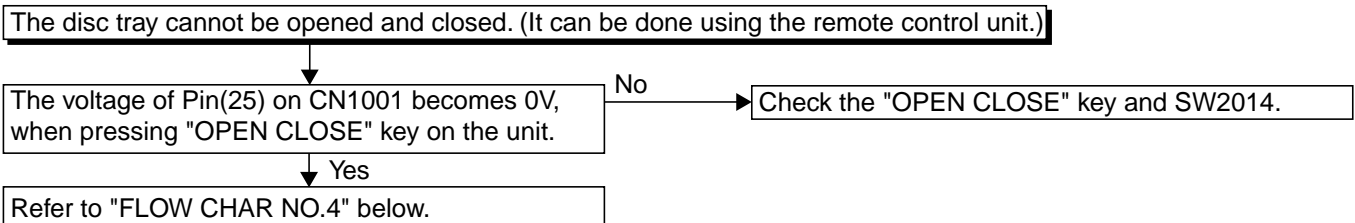
### FLOW CHART NO.1



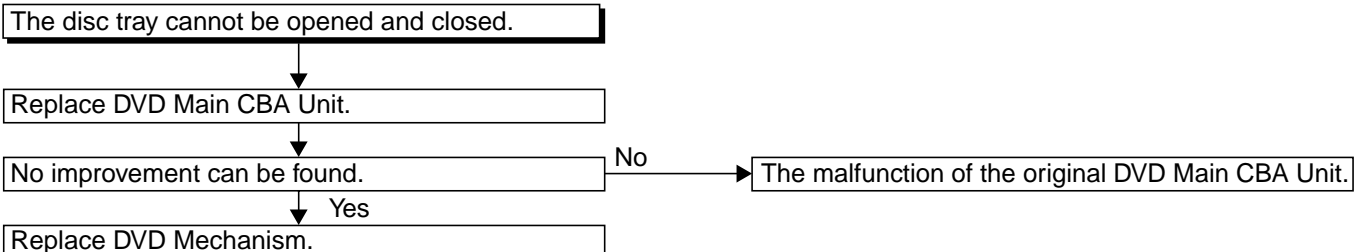
### FLOW CHART NO.2



### FLOW CHART NO.3



### FLOW CHART NO.4





### FLOW CHART NO.5

[No Disc] is indicated. (When the focus error occurs)

Replace DVD Main CBA Unit.

No improvement can be found.

No

The malfunction of the original DVD Main CBA Unit.

Yes

Replace DVD Mechanism.

### FLOW CHART NO.6

[No Disc] is indicated. (When the focus servo is not functioning.)

Replace DVD Main CBA Unit.

No improvement can be found.

No

The malfunction of the original DVD Main CBA Unit.

Yes

Replace DVD Mechanism.

### FLOW CHART NO.7

The [No Disc] indication. (When the laser beam does not light up.)

Replace DVD Main CBA Unit.

No improvement can be found.

No

The malfunction of the original DVD Main CBA Unit.

Yes

Replace DVD Mechanism.

### FLOW CHART NO.8

Both functions of picture and sound do not operate normally.

Replace DVD Main CBA Unit.

No improvement can be found.

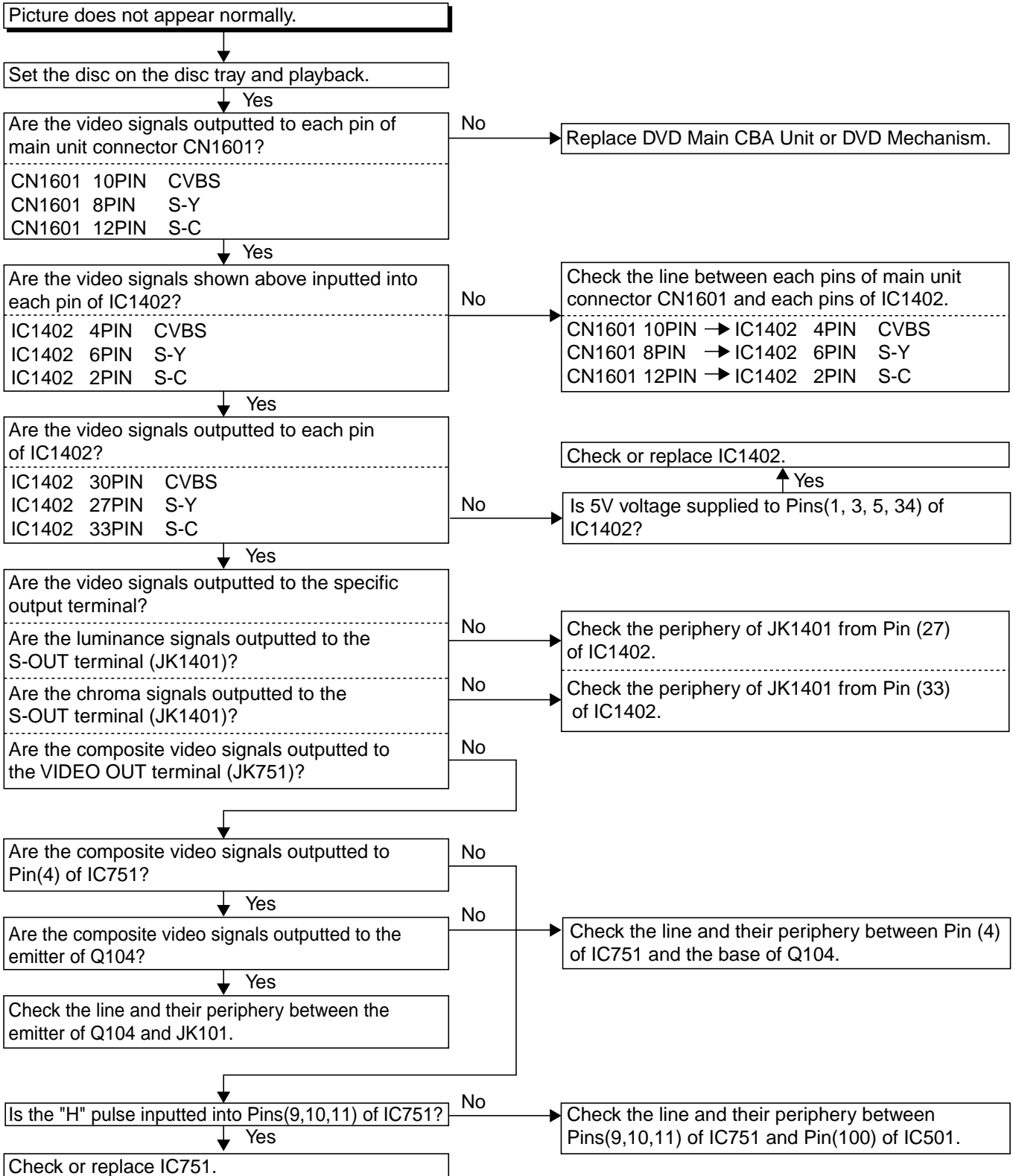
No

The malfunction of the original DVD Main CBA Unit.

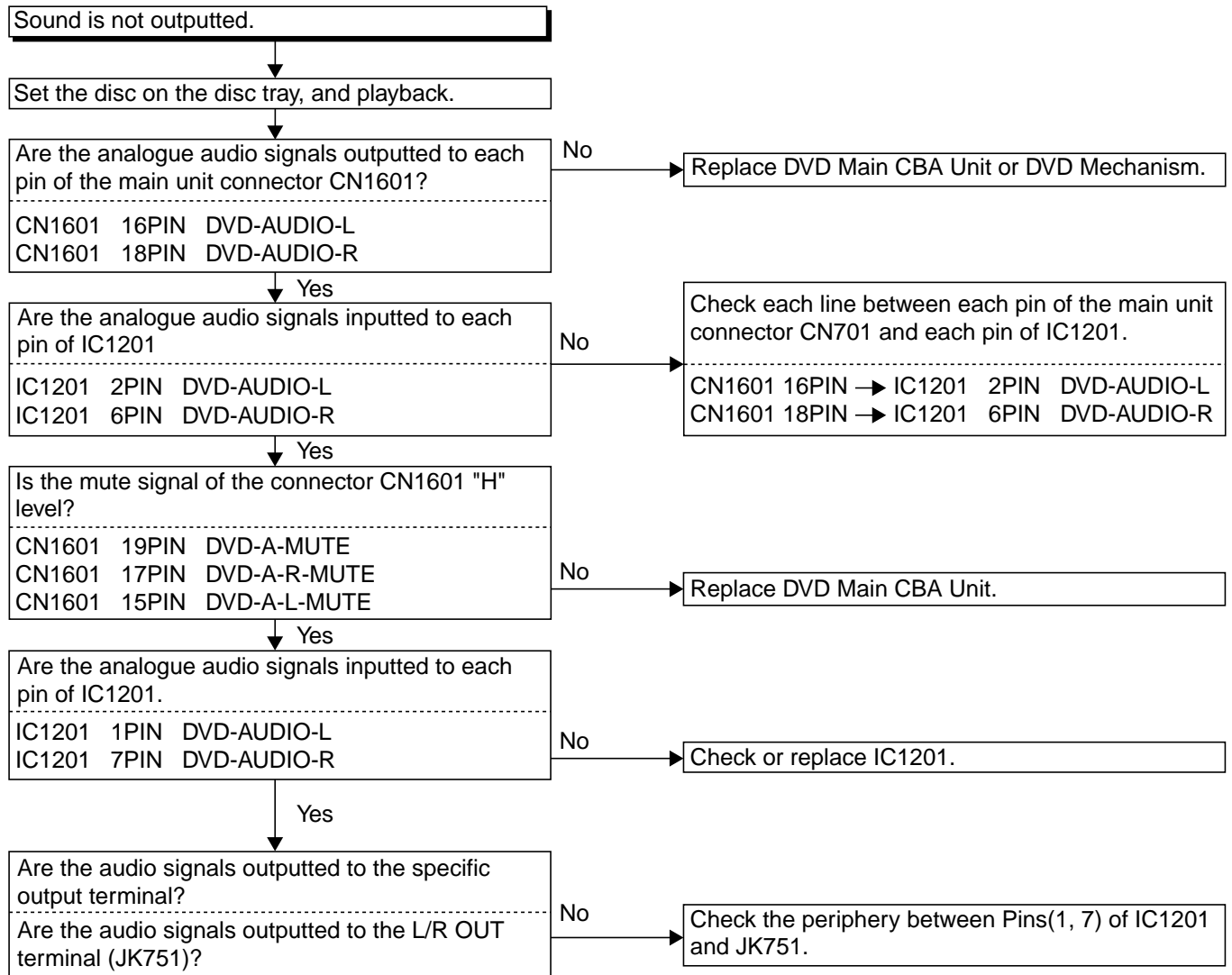
Yes

Replace DVD Mechanism.

**FLOW CHART NO.9**

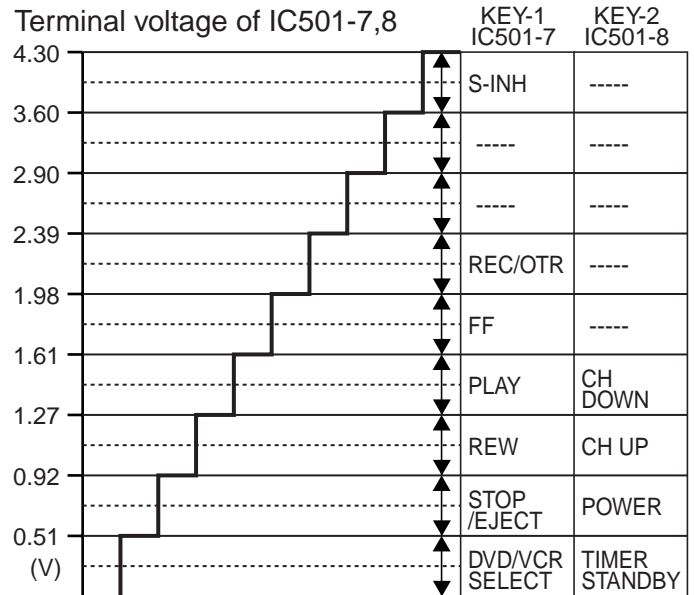
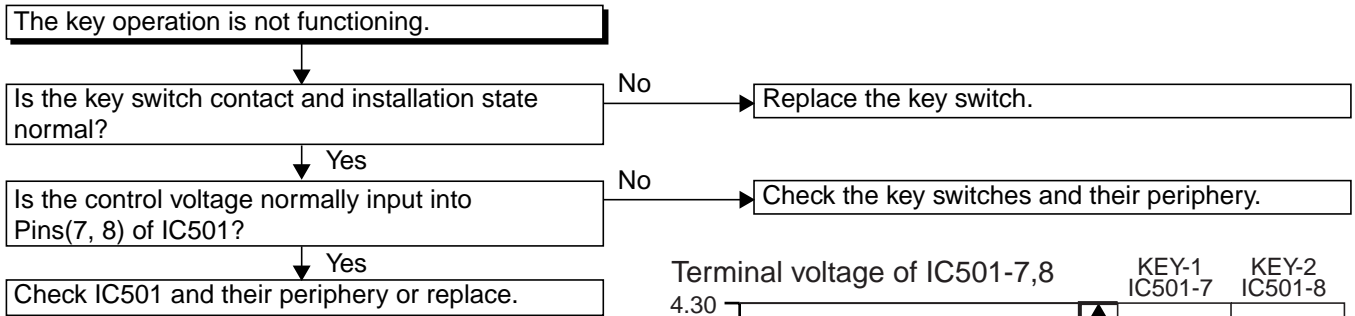


**FLOW CHART NO.10**

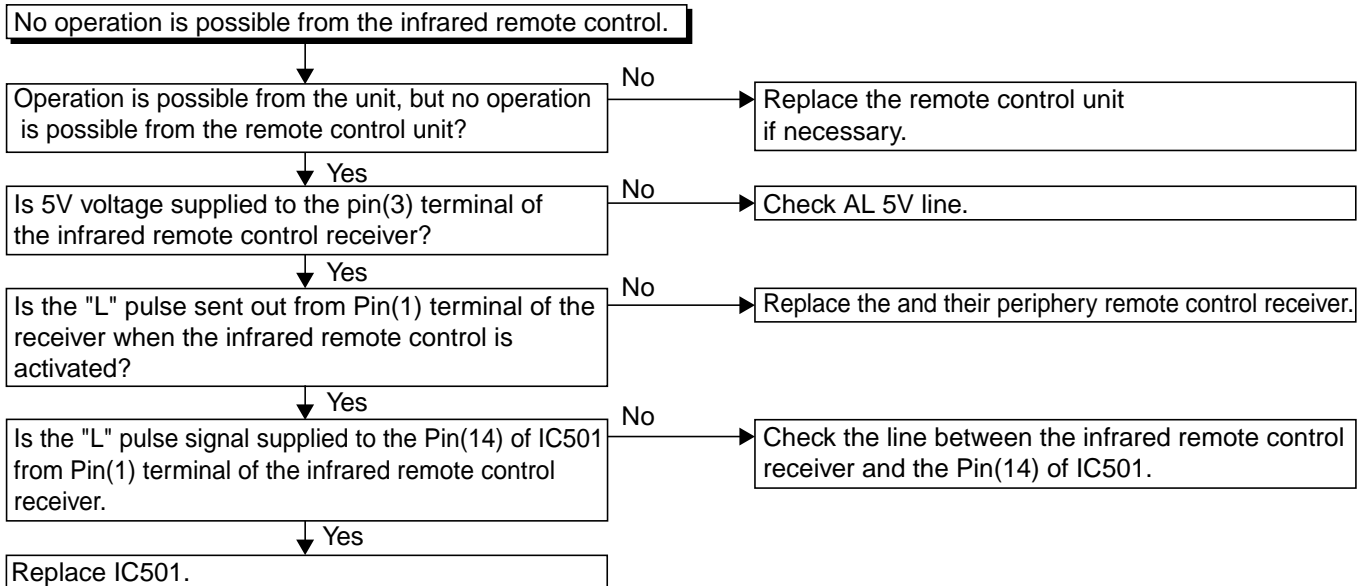


# [ VCR SECTION ]

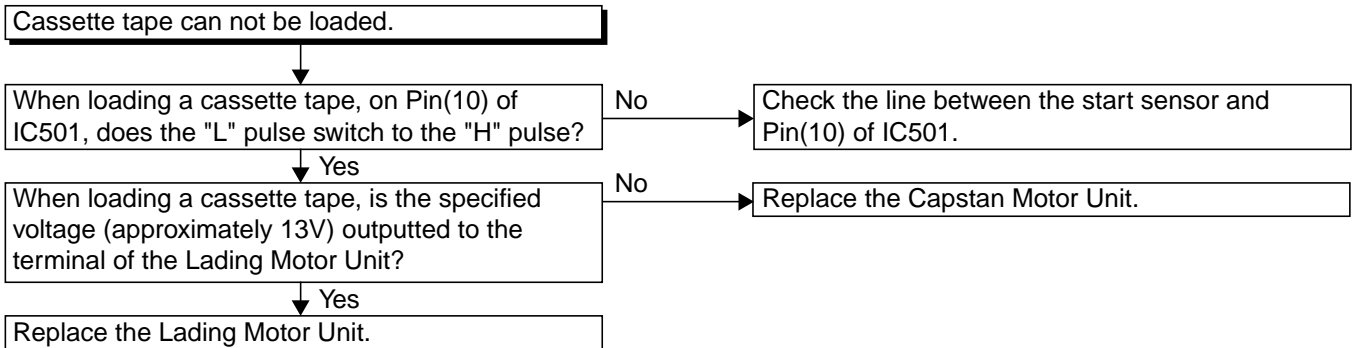
## FLOW CHART NO.1



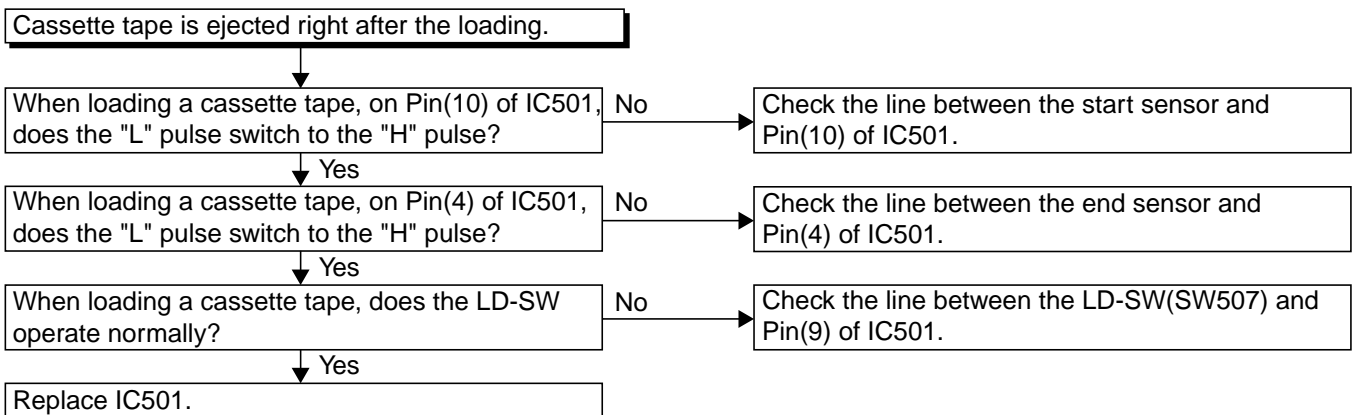
## FLOW CHART NO.2



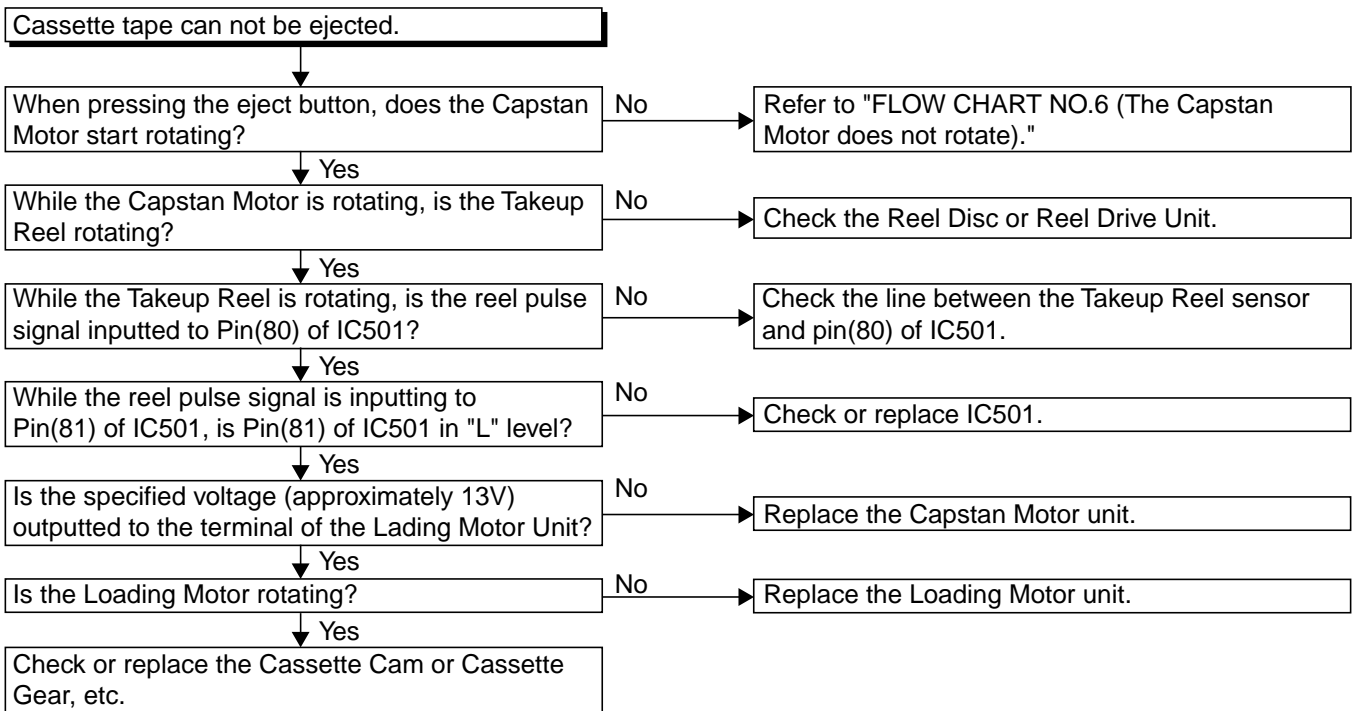
### FLOW CHART NO.3



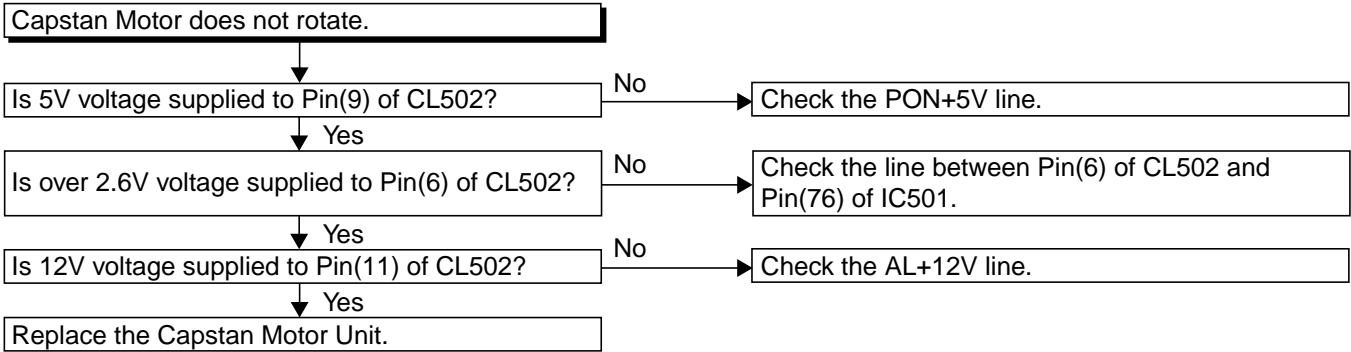
### FLOW CHART NO.4



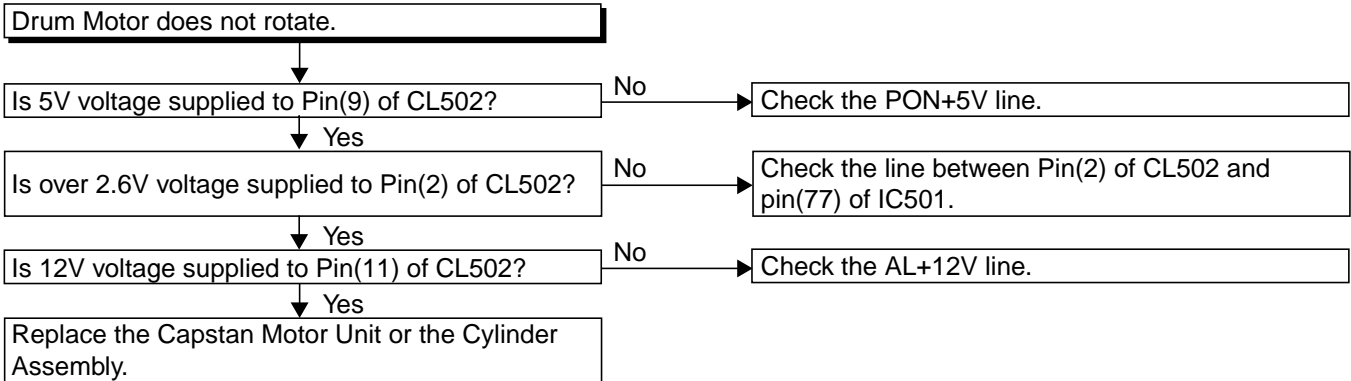
### FLOW CHART NO.5



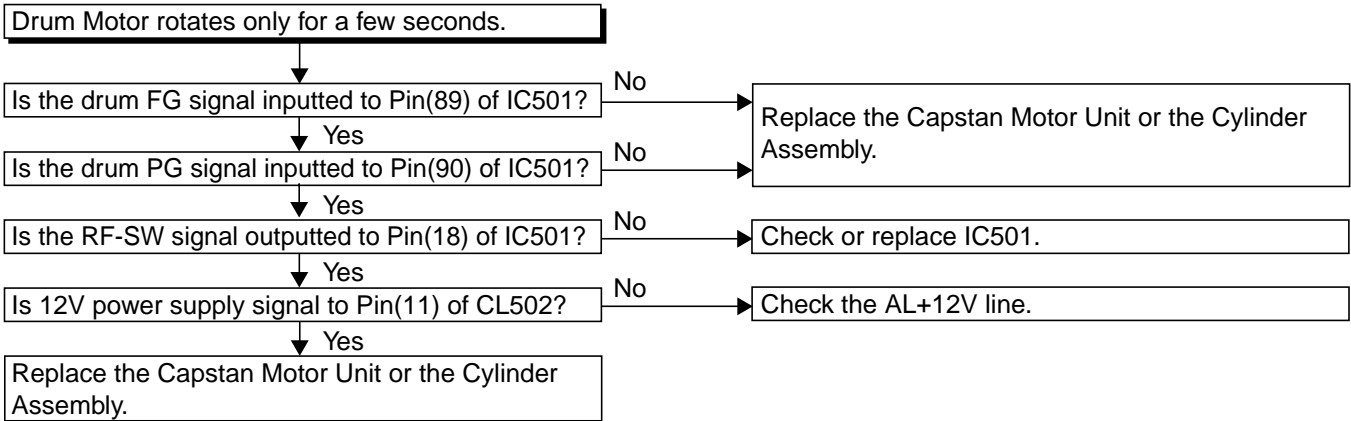
**FLOW CHART NO.6**



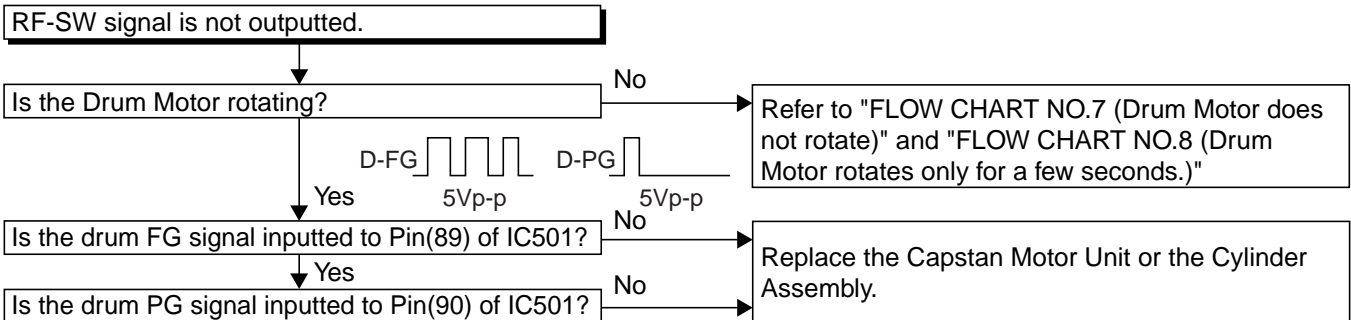
**FLOW CHART NO.7**



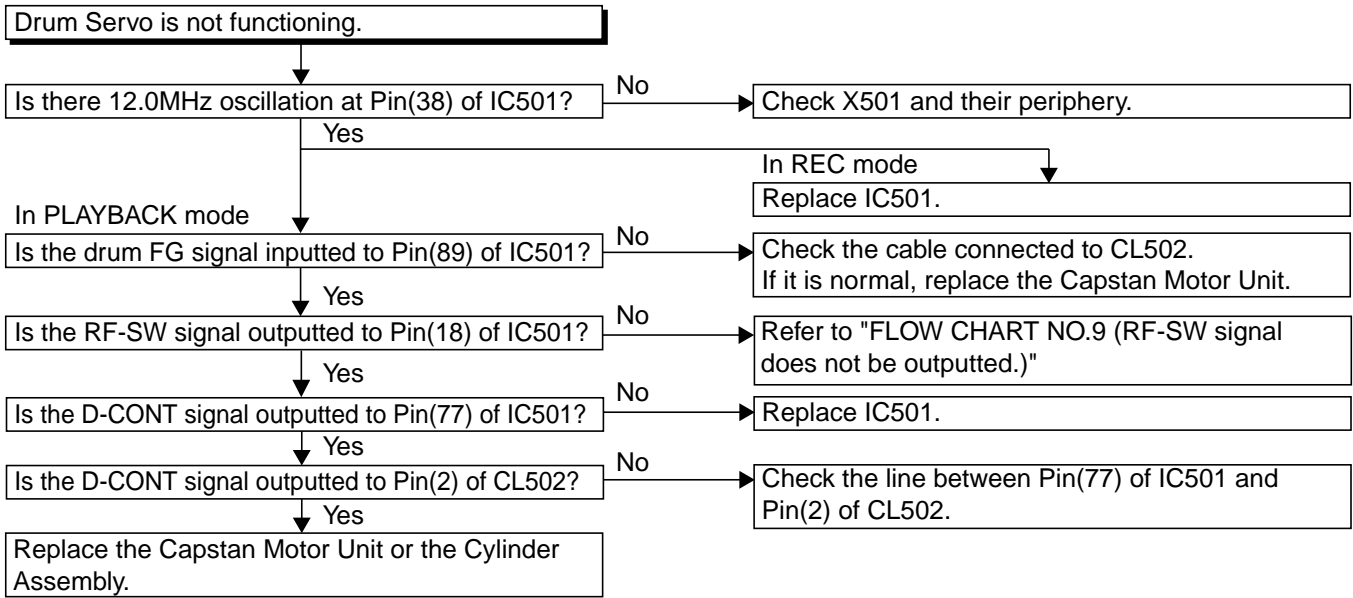
**FLOW CHART NO.8**



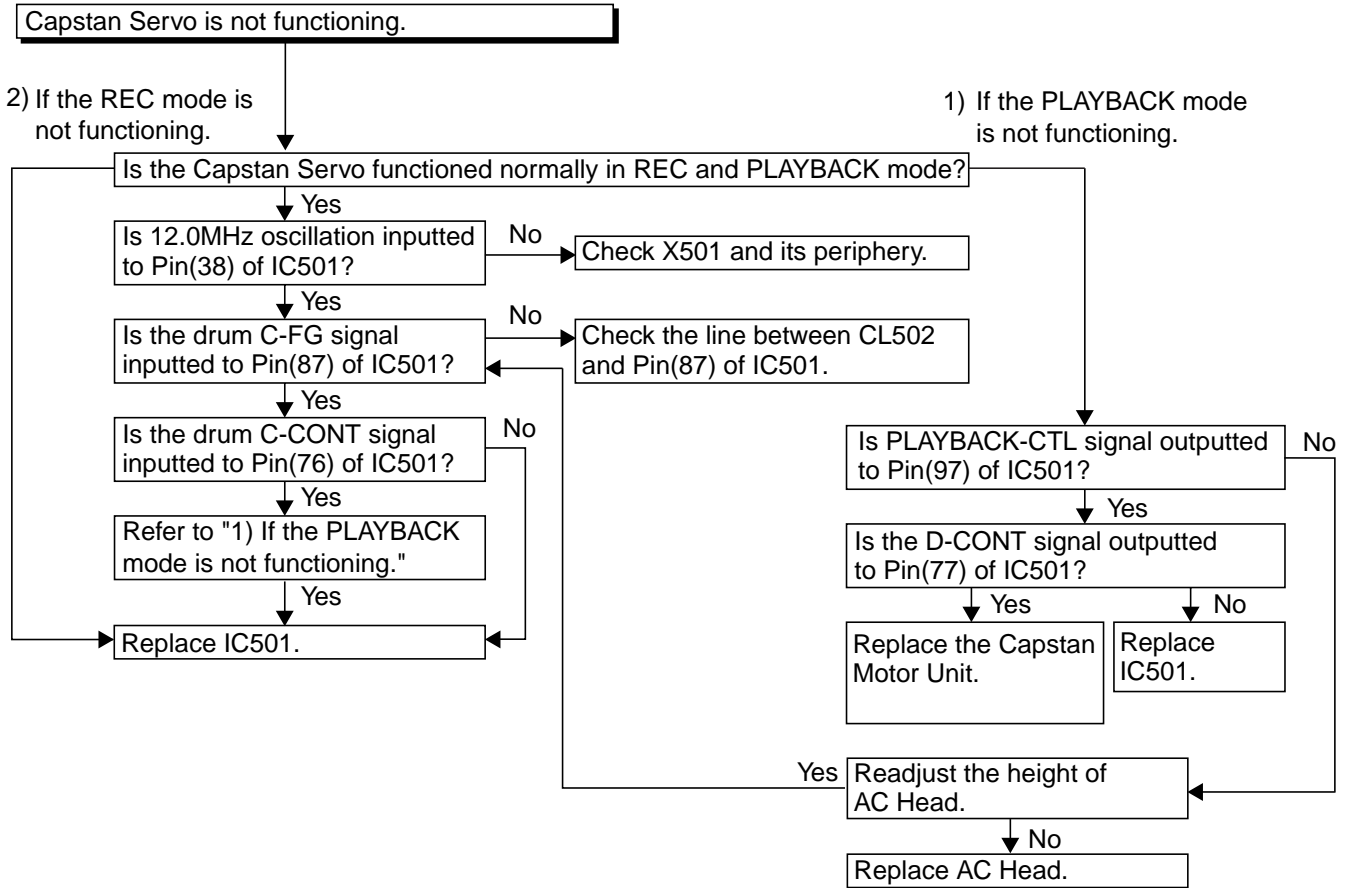
**FLOW CHART NO.9**



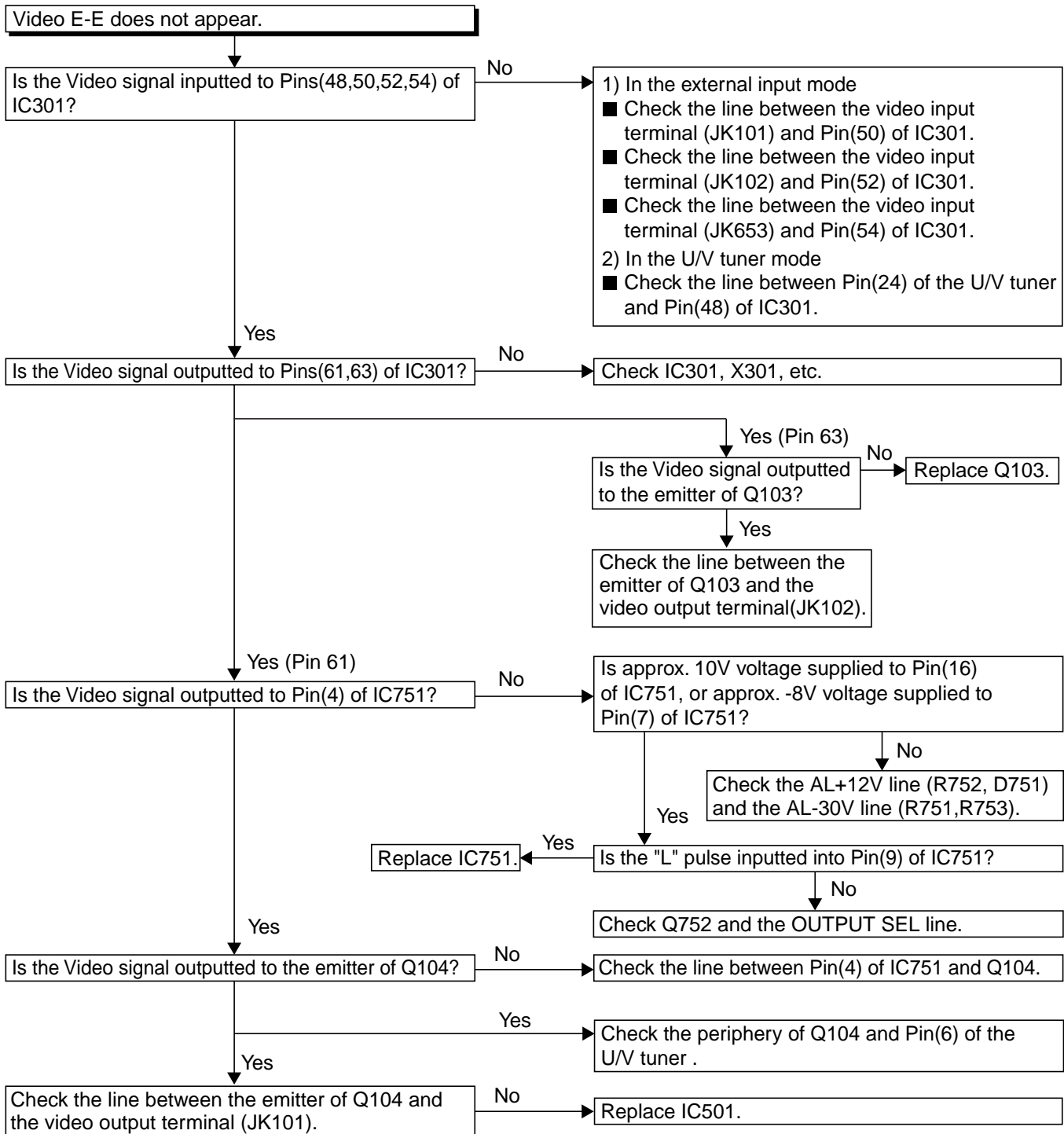
**FLOW CHART NO.10**



**FLOW CHART NO.11**



**FLOW CHART NO.12**

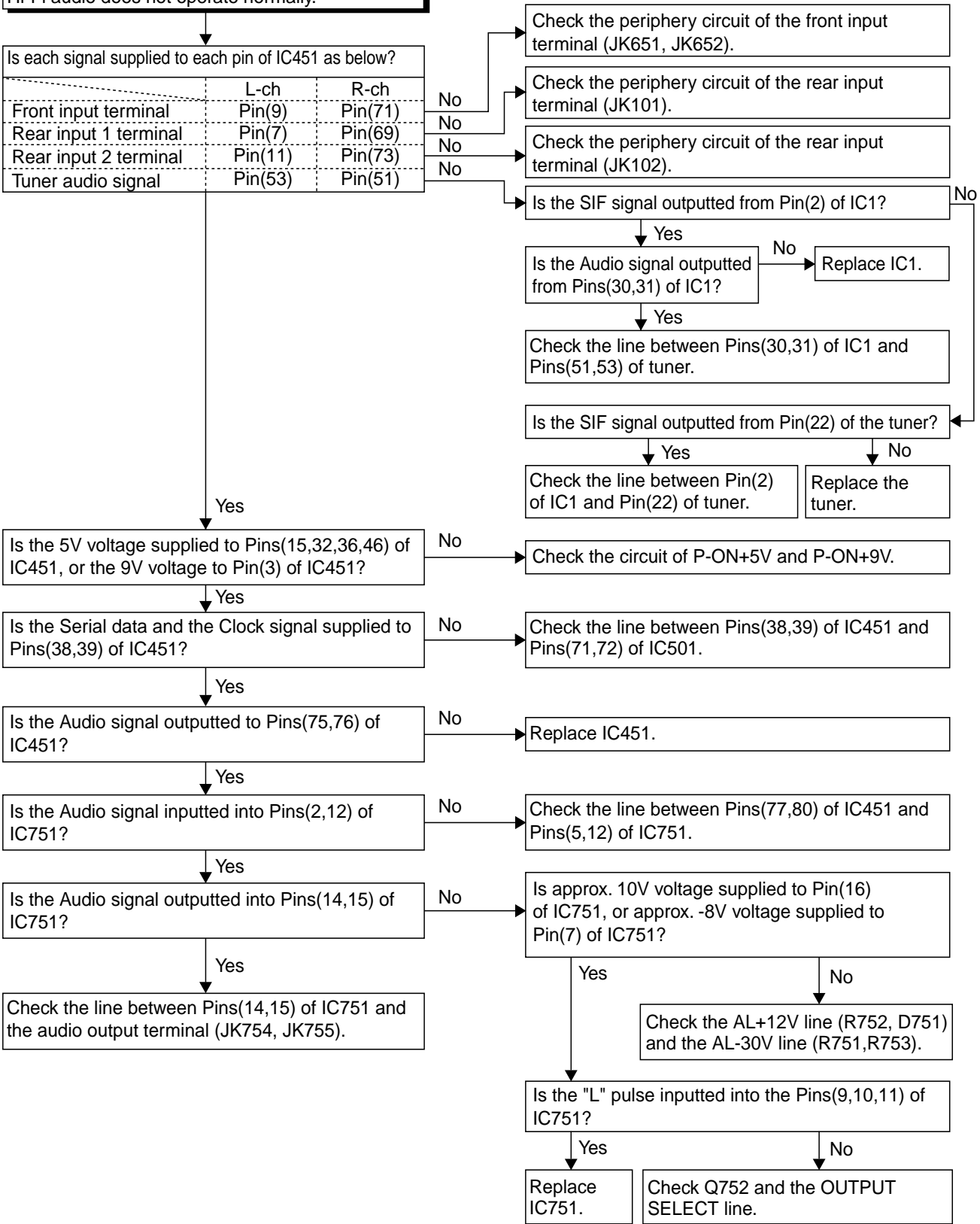




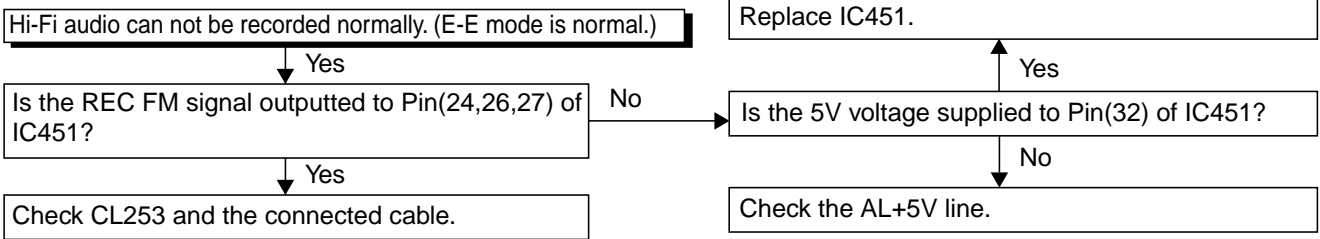
**FLOW CHART NO.13**

Hi-Fi audio does not operate normally.

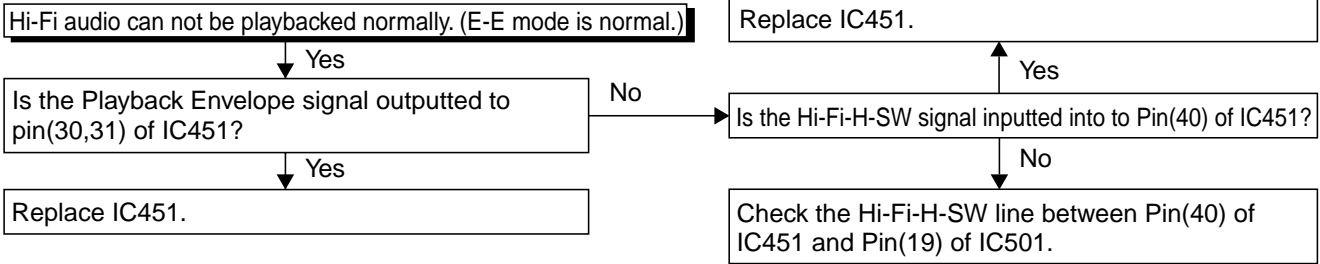
Is each signal supplied to each pin of IC451 as below?		
	L-ch	R-ch
Front input terminal	Pin(9)	Pin(71)
Rear input 1 terminal	Pin(7)	Pin(69)
Rear input 2 terminal	Pin(11)	Pin(73)
Tuner audio signal	Pin(53)	Pin(51)



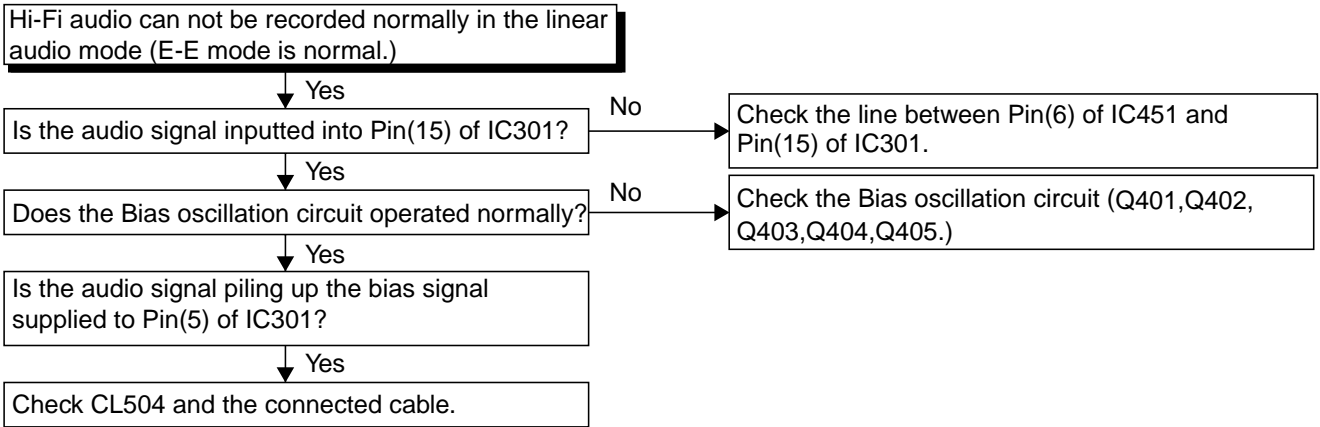
**FLOW CHART NO.14**



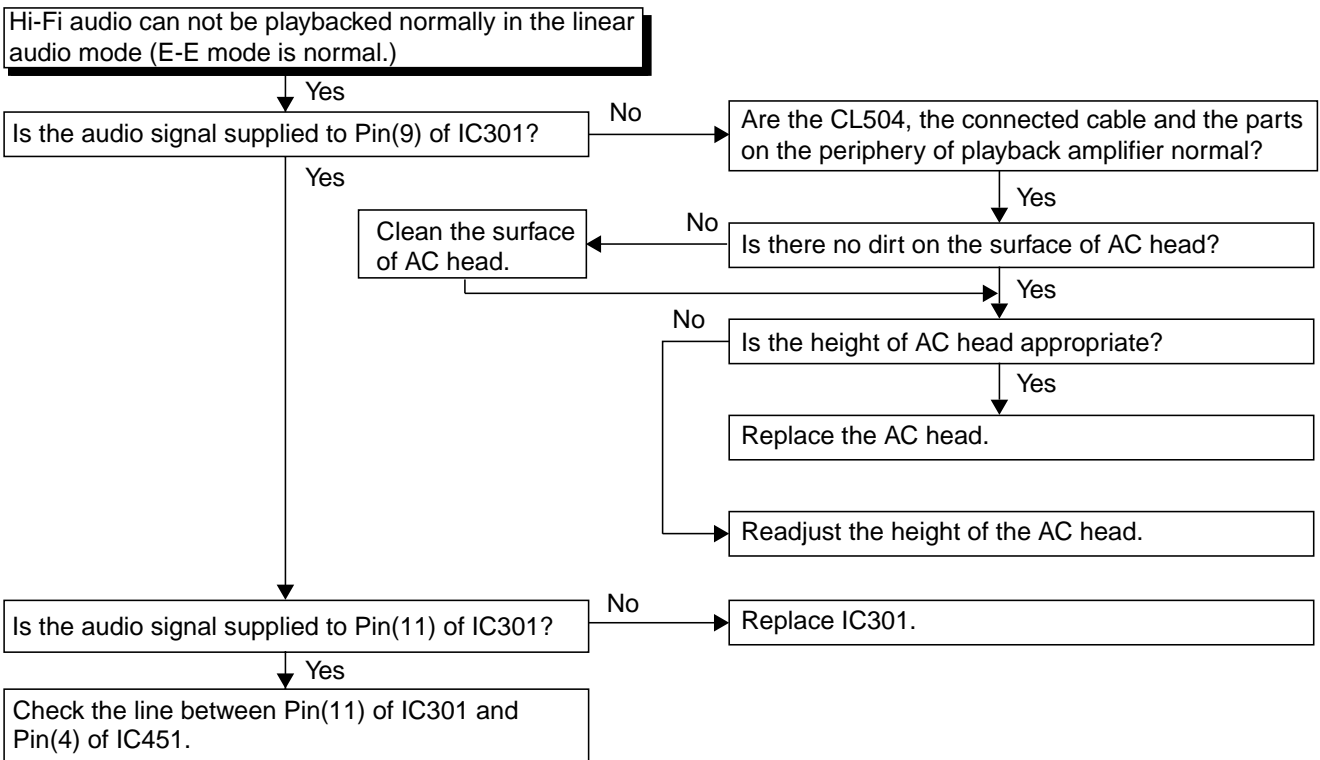
**FLOW CHART NO.15**



**FLOW CHART NO.16**



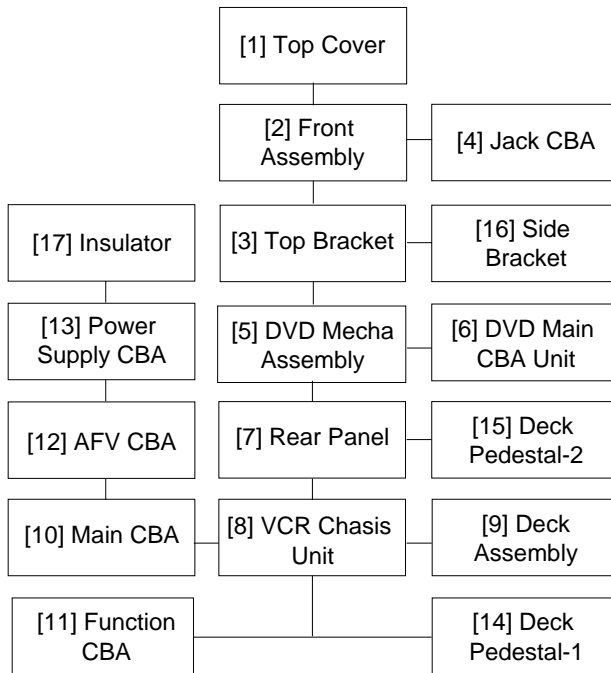
**FLOW CHART NO.17**



## CABINET DISASSEMBLY INSTRUCTIONS

### 1. Disassembly Flowchart

This flowchart indicates the disassembly steps to gain access to item(s) to be serviced. When reassembling, follow the steps in reverse order. Bend, route, and dress the cables as they were originally.



### 2. Disassembly Method

ID/LOC. No.	PART	REMOVAL		
		Fig. No.	REMOVE/*UNHOOK/ UNLOCK/RELEASE/ UNPLUG/DESOLDER	Note
[1]	Top Cover	D1	8(S-1)	-
[2]	Front Assembly	D2	(S-1A), *CN505, *2(L-1), Tray Panel, *7(L-2)	1-1 1-2 1-3 1-4 1-5 1-6 1-7 1-8
[3]	Top Bracket	D2	4(S-2)	-
[4]	Jack CBA	D3	3(S-3)	-
[5]	DVD Mecha Assembly	D4	3(S-4), *CN501, *CN701	-

ID/LOC. No.	PART	REMOVAL		
		Fig. No.	REMOVE/*UNHOOK/ UNLOCK/RELEASE/ UNPLUG/DESOLDER	Note
[6]	DVD Main CBA Unit	D5	3(S-5), *CN101, *CN401	2 2-1 2-2 2-3 3
[7]	Rear Panel	D6	3(S-6), 3(S-7)	-
[8]	VCR Chassis Unit	D7	*CN001, *CN002, 5(S-8), 5(S-9)	-
[9]	Deck Assembly	D8	Desolder, 2(S-10)	4,5
[10]	Main CBA	D8	-----	-
[11]	Function CBA	D8	Desolder, *CN2002	-
[12]	AFV CBA	D8	Desolder	-
[13]	Power Supply CBA	D9	3(S-11), Bracket, *(L-3)	-
[14]	Deck Pedestal-1	D9	6(S-12), 3(W-1)	-
[15]	Deck Pedestal-2	D9	(S-13)	-
[16]	Side Bracket	D9	(S-14)	-
[17]	Insulator	D9	-----	-

↓                      ↓                      ↓                      ↓                      ↓  
(1)                      (2)                      (3)                      (4)                      (5)

#### Note:

- (1): Identification (location) No. of parts in the figures
- (2): Name of the part
- (3): Figure Number for reference
- (4): Identification of parts to be removed, unhooked, unlocked, released, unplugged, unclamped, or desoldered.  
P=Spring, L=Locking Tab, S=Screw,  
CN=Connector, W=Washer  
\*=Unhook, Unlock, Release, Unplug, or Desolder  
e.g. 2(S-2) = two Screws (S-2),  
2(L-2) = two Locking Tabs (L-2)
- (5): Refer to "Reference Notes."

## Reference Notes

**CAUTION 1:** Locking Tabs (L-1) and (L-2) are fragile. Be careful not to break them.

- 1-1. Connect the wall plug to an AC outlet and press the OPEN/CLOSE button to open the Tray.
- 1-2. Remove the Tray Panel by releasing two Locking Tabs (L-1).
- 1-3. Press the OPEN/CLOSE button again to close the Tray.
- 1-4. Press the POWER button to turn the power off.
- 1-5. Unplug an AC cord.
- 1-6. Disconnect connector CN505.
- 1-7. Remove Screw (S-1A).
- 1-8. Release seven Locking Tabs (L-2) (to do this, first release five Locking Tabs (A) at the side and top, and then release two Locking Tabs (B) at the bottom.)

**CAUTION 2:** Electrostatic breakdown of the laser diode in the optical system block may occur as a potential difference caused by electrostatic charge accumulated on cloth, human body etc., during unpacking or repair work.

To avoid damage of pickup follow next procedures.

- 2-1. Slide the pickup unit as shown in Fig. D5.
- 2-2. Short the three short lands of FPC cable with solder before removing the FFC cable (CN101) from it. If you disconnect the FFC cable (CN101), the laser diode of pickup will be destroyed. (Fig. D5)
- 2-3. Disconnect Connector (CN401). Remove three Screws (S-5) and lift the DVD Main CBA Unit. (Fig. D5)

**CAUTION 3:** When reassembling, confirm the FFC cable (CN101) is connected completely. Then remove the solder from the three short lands of FPC cable. (Fig. D5)

4. When reassembling, solder wire jumpers as shown in Fig. D8.
5. Before installing the Deck Assembly, be sure to place the pin of LD-SW on Main CBA as shown in Fig. D8. Then, install the Deck Assembly while aligning the hole of Cam Gear with the pin of LD-SW, the shaft of Cam Gear with the hole of LD-SW as shown in Fig. D8.

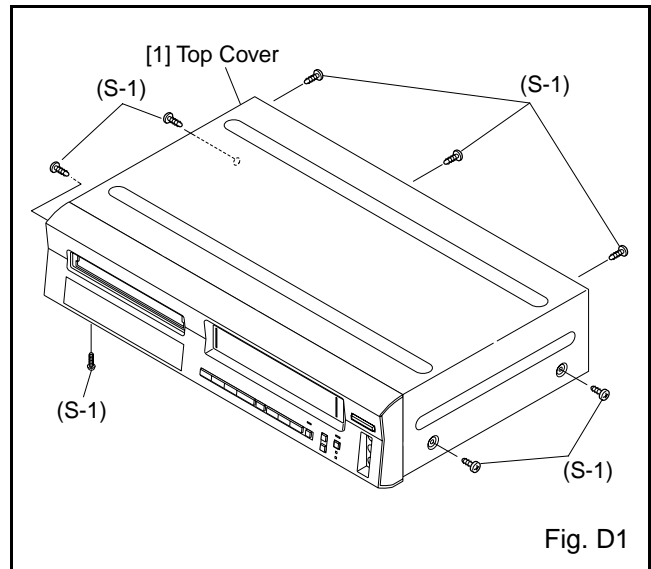


Fig. D1

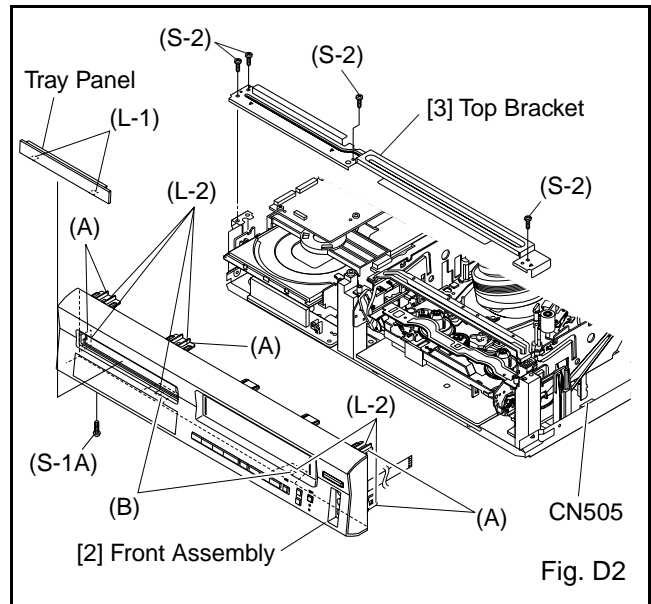


Fig. D2

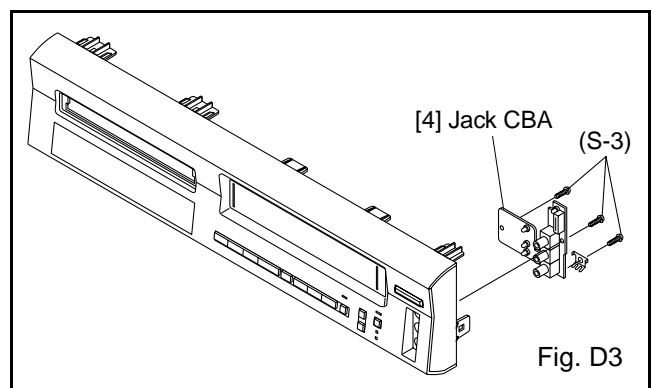
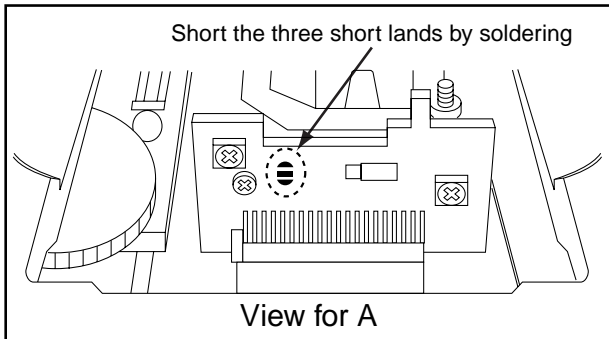
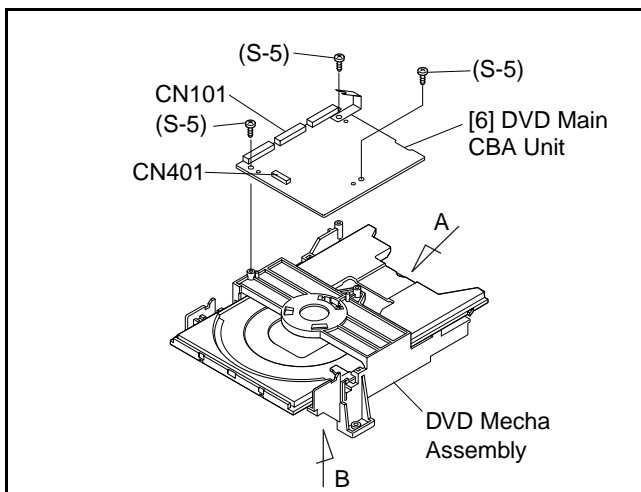
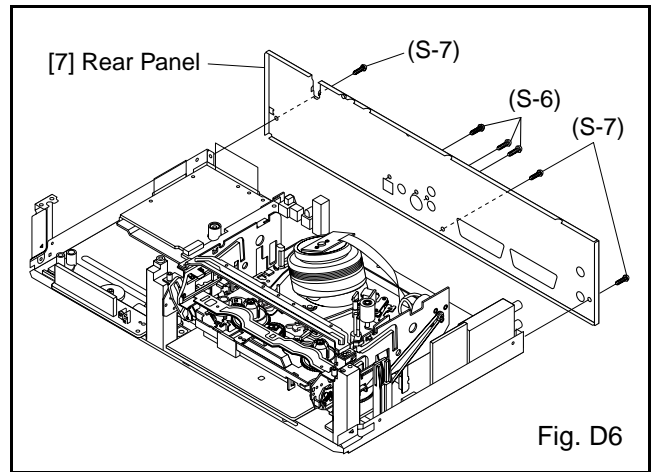
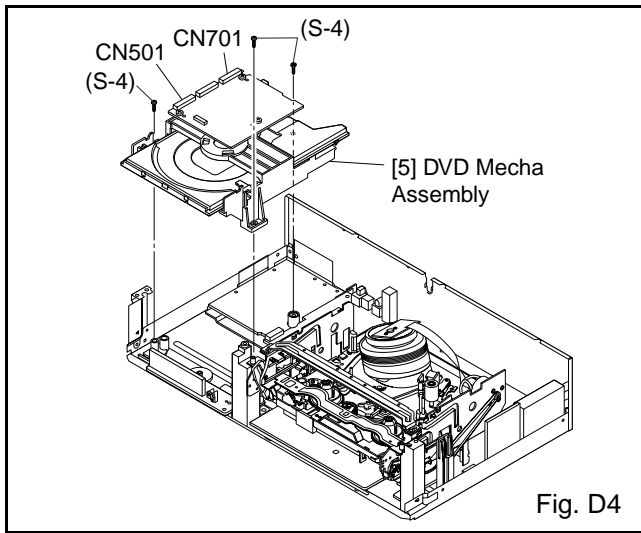


Fig. D3



OR

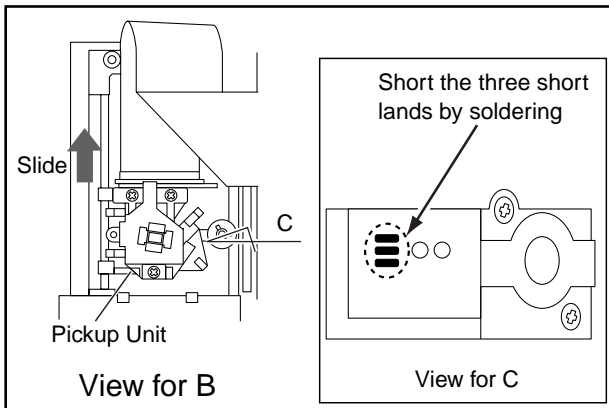
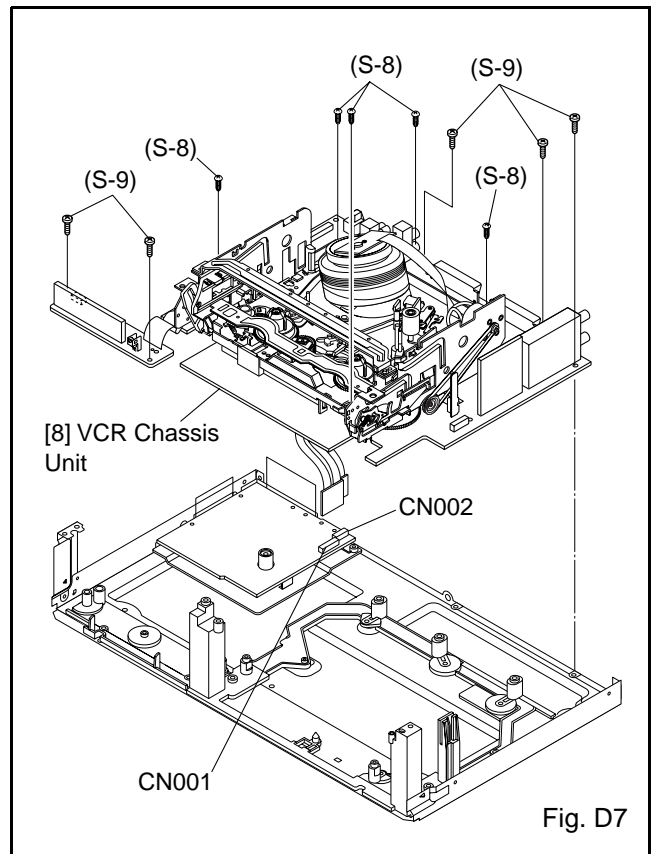


Fig. D5



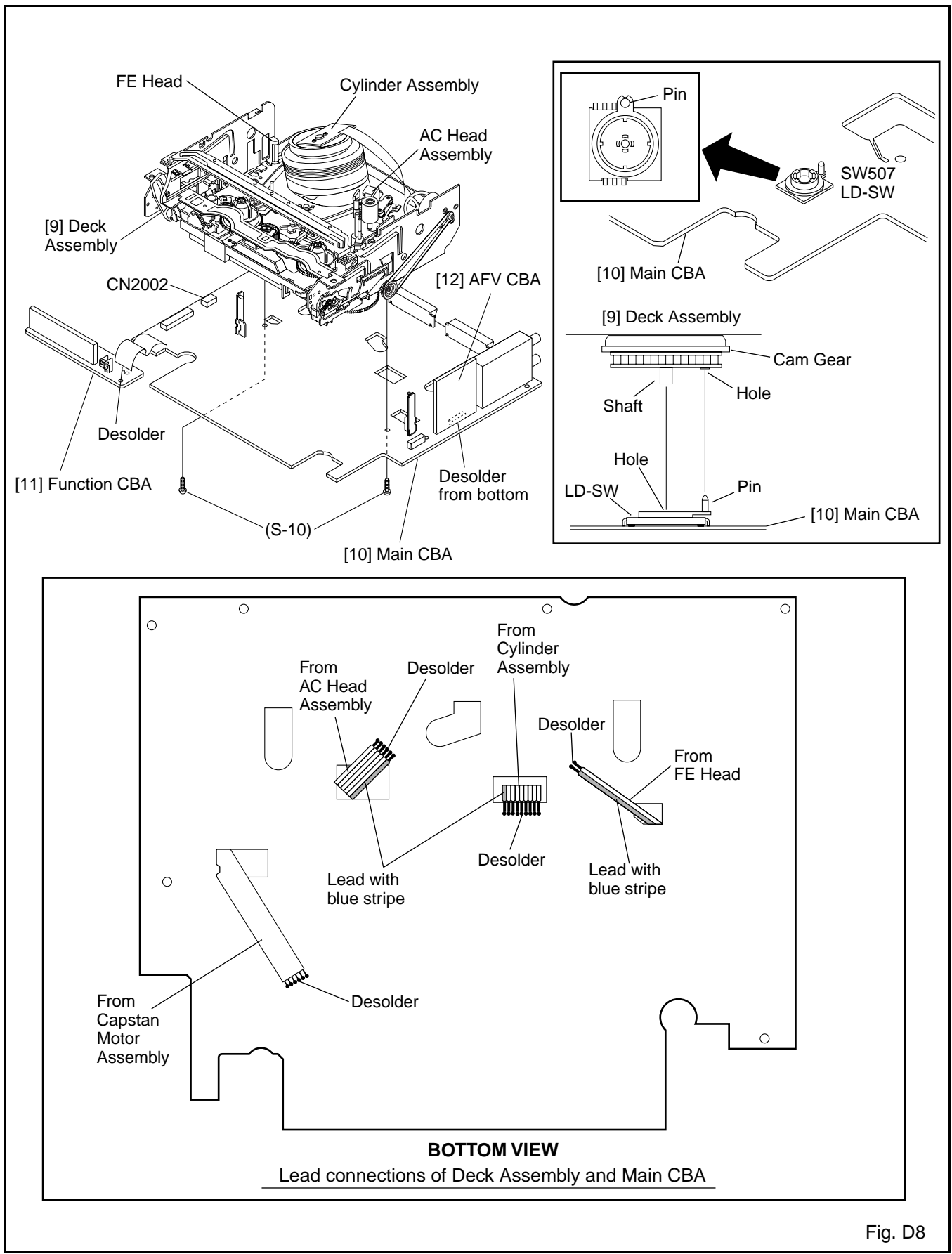


Fig. D8

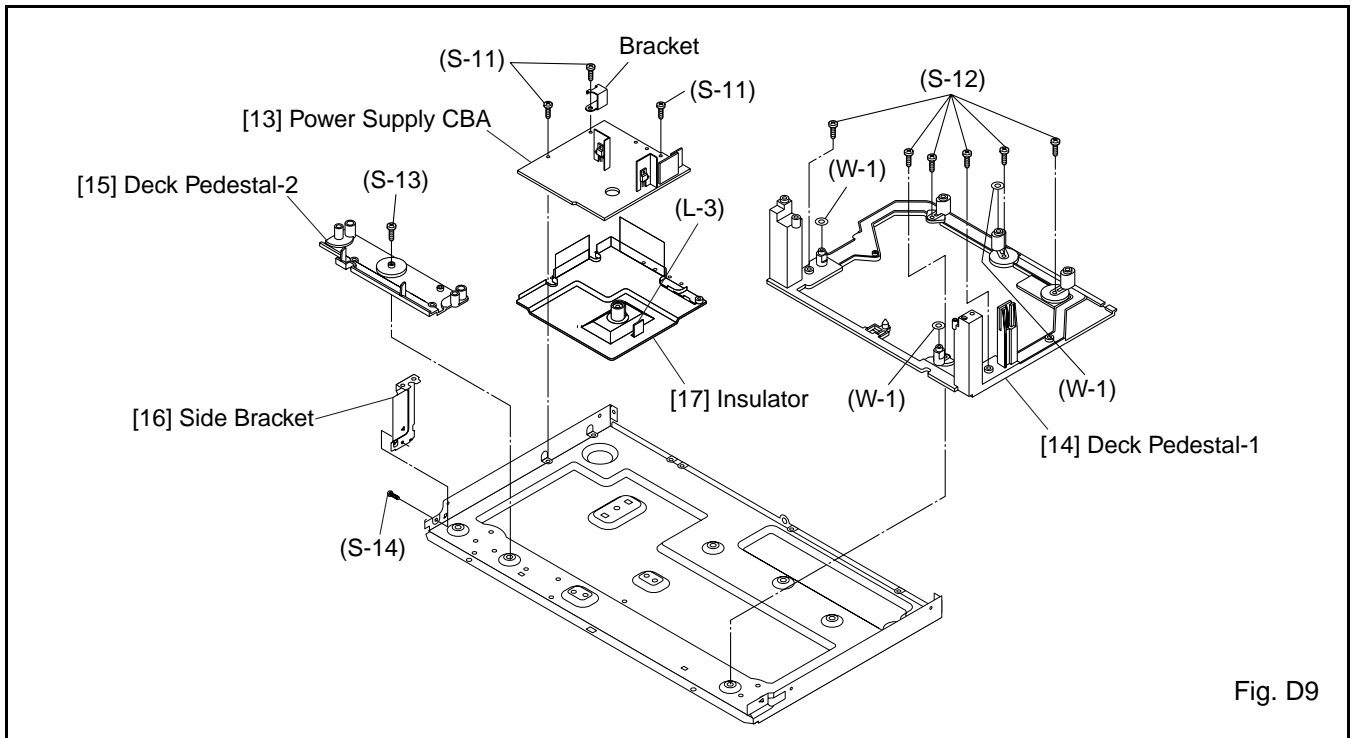
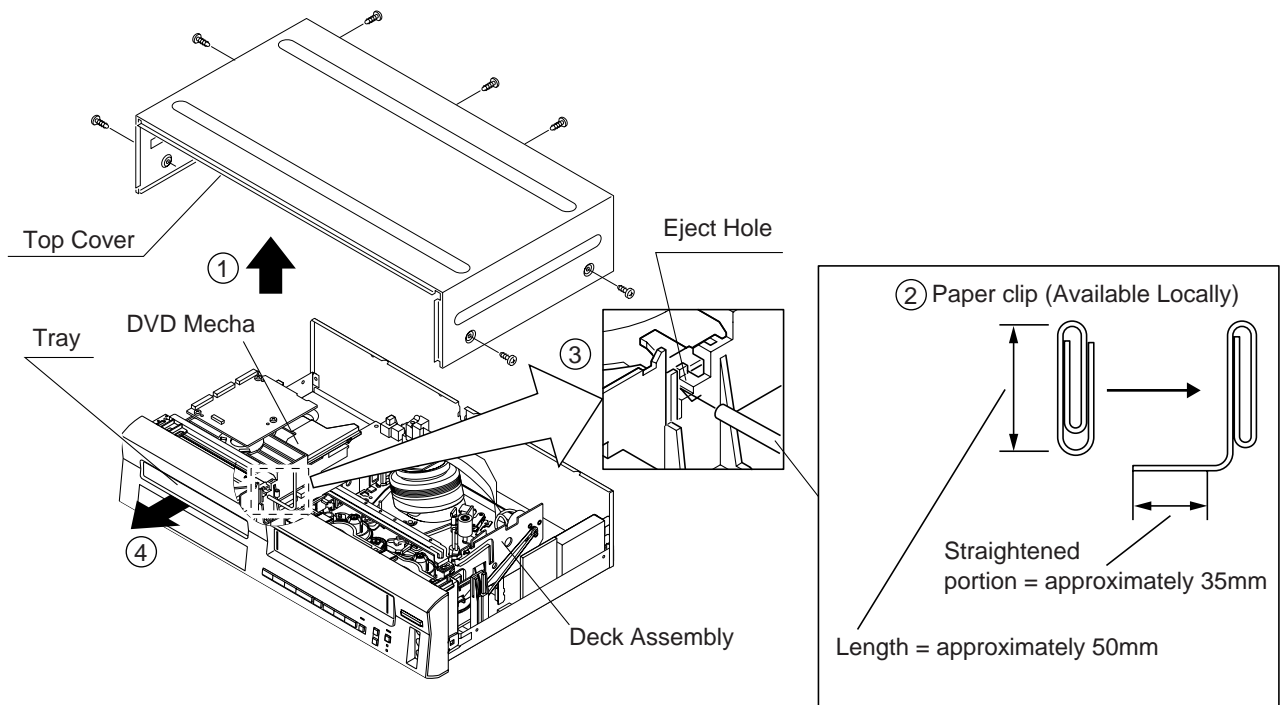


Fig. D9

## HOW TO MANUAL EJECT

1. Remove the Top Case.
2. Make a tool from a paper clip, etc., (length = approximately 50 mm, maximum diameter = approximately 3 mm) as shown below.
3. Insert the tool into the manual eject hole on the DVD Mecha. Then, push it until the tray is ejected.



# DISASSEMBLY/ASSEMBLY PROCEDURES OF DECK MECHANISM

Before following the procedures described below, be sure to remove the deck assembly from the cabinet. (Refer to CABINET DISASSEMBLY INSTRUCTIONS on page E2-1-1.)

All the following procedures, including those for adjustment and replacement of parts, should be done in Eject mode; see the positions of [41] and [42] in Fig.DM1 on page E2-2-3. When reassembling, follow the steps in reverse order.

STEP /LOC. No.	START-ING No.	PART		REMOVAL		INSTALLATION
				Fig. No.	REMOVE/*UNHOOK/ UNLOCK/RELEASE/ UNPLUG/DESOLDER	ADJUSTMENT CONDITION
[1]	[1]	Guide Holder A	T	DM3	2(S-1)	
[2]	[1]	Cassette Holder Assembly	T	DM4		
[3]	[2]	Slider L	T	DM5	(S-2)	
[4]	[2]	Slider R	T	DM5	(S-3)	
[5]	[4]	Lock Lever	T	DM5	(S-4),*(P-1)	
[6]	[2]	C Plate	T	DM5		
[7]	[7]	Cylinder Assembly	T	DM1,DM6	Desolder, 3(S-5)	
[8]	[8]	Loading Motor Assembly	T	DM1,DM7	Desolder, LDG Belt, 2(S-6)	
[9]	[9]	AC Head Assembly	T	DM1,DM7	(S-7)	
[10]	[2]	Tape Guide Assembly	T	DM1,DM8	*(P-2)	
[11]	[10]	Door Opener B	T	DM1,DM8	*(L-1),*(L-2)	
[12]	[11]	Pinch Arm (B)	T	DM1,DM8	*(P-3)	
[13]	[12]	Pinch Arm (A) Assembly	T	DM1,DM8		
[14]	[14]	FE Head	T	DM1,DM9	(S-9)	
[15]	[15]	Prism	T	DM1,DM9	(S-10)	
[16]	[2]	Slider Shaft	T	DM10	(S-11),*(L-3)	
[17]	[16]	C Drive Lever L	T	DM10		
[18]	[16]	C Drive Lever R	T	DM10		
[19]	[7],[10]	Capstan Motor	B	DM2,DM11	3(S-12), Cap Belt	
[20]	[20]	Clutch Assembly(HI)	B	DM2,DM12	(C-1)	
[21]	[20]	Center Gear	B	DM12		
[22]	[22]	Cam Holder F	B	DM2,DM13	(C-2)	
[23]	[22]	Cam Gear (B)	B	DM2,DM13	(C-3),*(P-4)	
[24]	[24]	Mode Gear	B	DM2,DM14	(C-4)	
[25]	[20],[23], [24]	Mode Lever(HI)	B	DM2,DM14	(C-5), *(L-4)	
[26]	[22]	Worm Holder	B	DM2,DM14	(S-15)	
[27]	[26]	Pulley Assembly	B	DM2,DM14		
[28]	[22],[25]	Cam Gear (A)	B	DM2,DM14		(+)Refer to Alignment Sec.Pg.E2-3-2
[29]	[20]	TR Gear C	B	DM2,DM14	(C-6)	
[30]	[29]	TR Gear Spring	B	DM14		
[31]	[30]	TR Gear A/B	B	DM1,DM14		
[32]	[31]	FF Arm(HI)	B	DM1,DM14		
[33]	[21],[25]	Idler Assembly(HI)	B	DM1,DM15	*(L-5)	
[34]	[25]	BT Arm	B	DM2,DM15	*(P-5)	



STEP /LOC. No.	START-ING No.	PART		REMOVAL		INSTALLATION
				Fig. No.	REMOVE/*UNHOOK/ UNLOCK/RELEASE/ UNPLUG/DESOLDER	ADJUSTMENT CONDITION
[35]	[25]	Loading Arm S(B) Assembly	B	DM2,DM15		(+)Refer to Alignment Sec.Pg.E2-3-1
[36]	[35]	Loading Arm T(B) Assembly	B	DM2,DM15		(+)Refer to Alignment Sec.Pg.E2-3-1
[37]	[2],[25]	M Brake T(HI) Assembly	T	DM1,DM16	*(P-6)	
[38]	[2],[25]	M Brake S(HI) Assembly	T	DM1,DM16	*(P-7)	
[39]	[38]	Tension Lever Sub Assembly	T	DM1,DM16		
[40]	[39]	T Lever Holder	T	DM1,DM16	*(L-6)	
[41]	[2]	M Gear(HYT)	T	DM1,DM16	(C-7)	
[42]	[2],[15]	Sensor Gear	T	DM1,DM16	(C-8)	
[43]	[37],[41]	Reel T	T	DM1,DM16		
[44]	[39]	Reel S	T	DM1,DM16		
[45]	[35],[38]	Moving Guide S Preparation	T	DM1,DM17		
[46]	[36]	Moving Guide T Preparation	T	DM1,DM17		
[47]	[19]	TG Post Assembly	T	DM1,DM17	*(L-7)	
[48]	[18],[28]	Rack Assembly	R	DM18		(+)Refer to Alignment Sec.Pg.E2-3-2
[49]	[48]	F Door Opener	R	DM18		
[50]	[46]	Cleaner Lever Assembly	T	DM1,DM6	*(L-8)	

↓                      ↓                      ↓                      ↓                      ↓                      ↓                      ↓  
 (1)                    (2)                    (3)                    (4)                    (5)                    (6)                    (7)

(1): Follow steps in sequence. When reassembling, follow the steps in reverse order.

These numbers are also used as Identification (location) No. of parts in the figures.

(2): Indicates the part to start disassembling with in order to disassemble the part in column (1).

(3): Name of the part

(4): Location of the part: T=Top B=Bottom R=Right L=Left

(5): Figure Number

(6): Identification of parts to be removed, unhooked, unlocked, released, unplugged, unclamped, or desoldered.

P=Spring, W=Washer, C=Cut Washer, S=Screw, \*=Unhook, Unlock, Release, Unplug, or Desolder

e.g., 2(L-2) = two Locking Tabs (L-2).

(7): Adjustment Information for Installation

(+):Refer to Deck Exploded Views for lubrication.

\* In case of some models, the Cleaner Lever Assembly and CL Post is not used.

# Top View

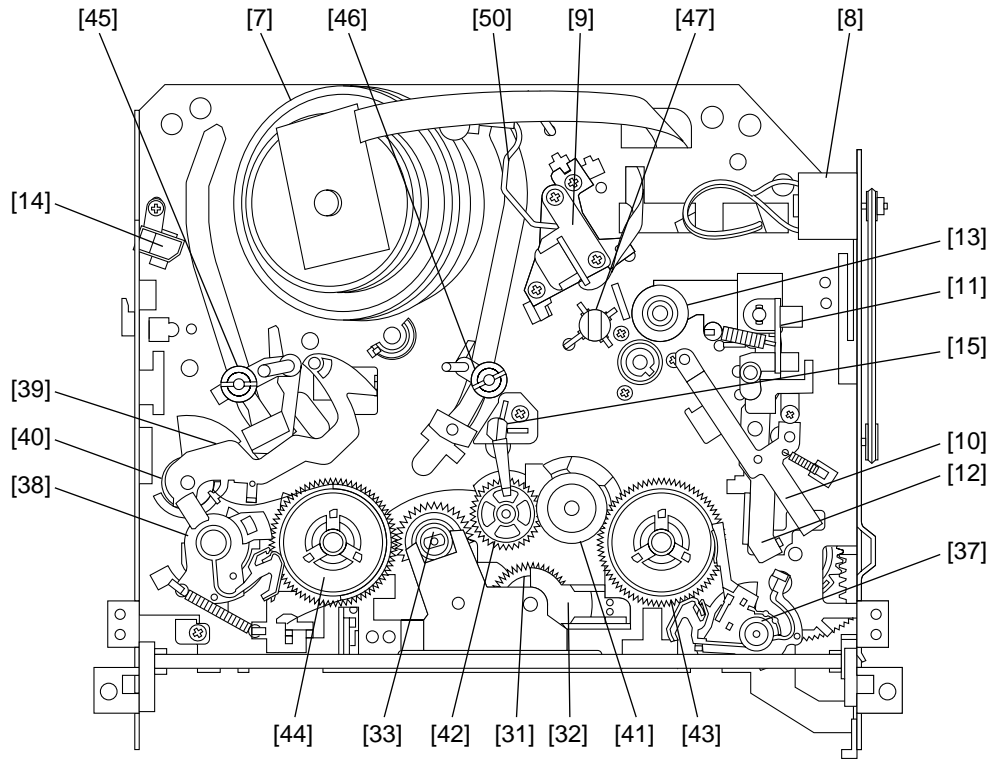


Fig. DM1

# Bottom View

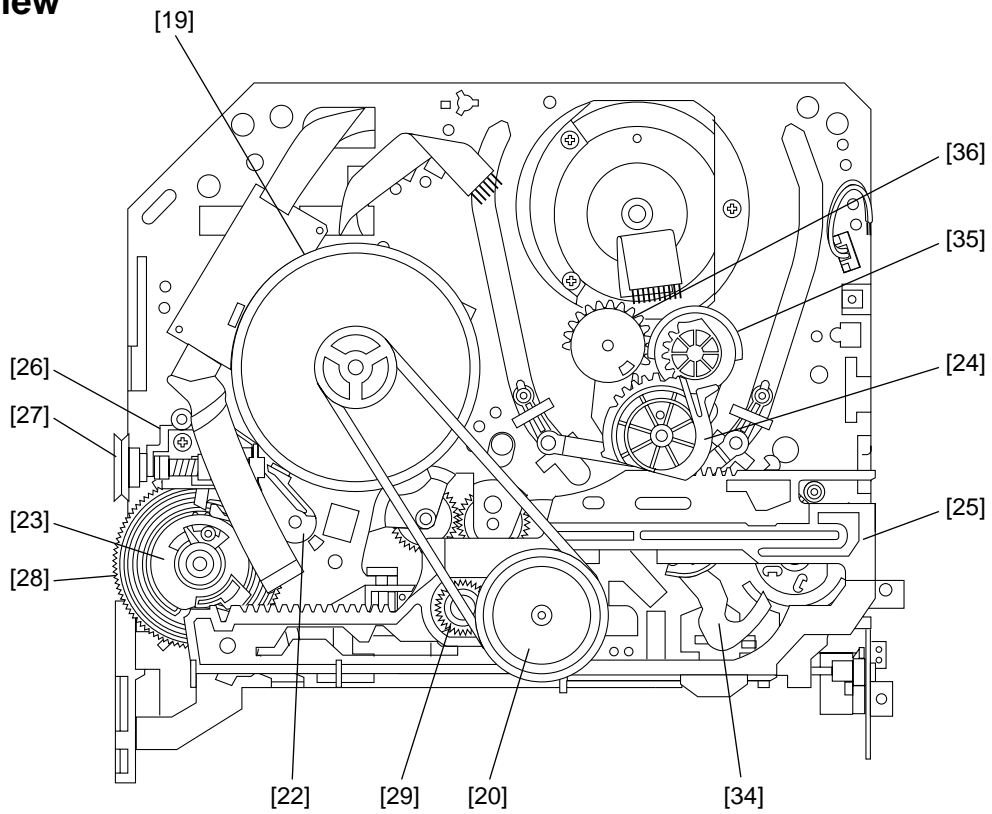
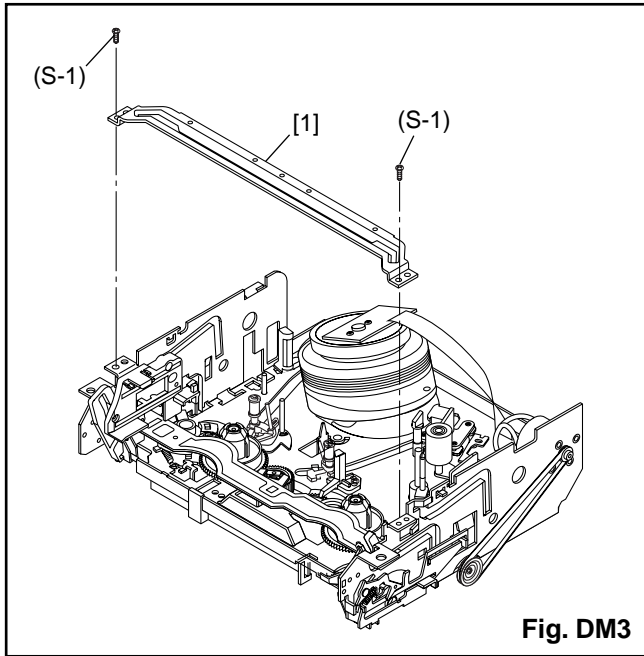
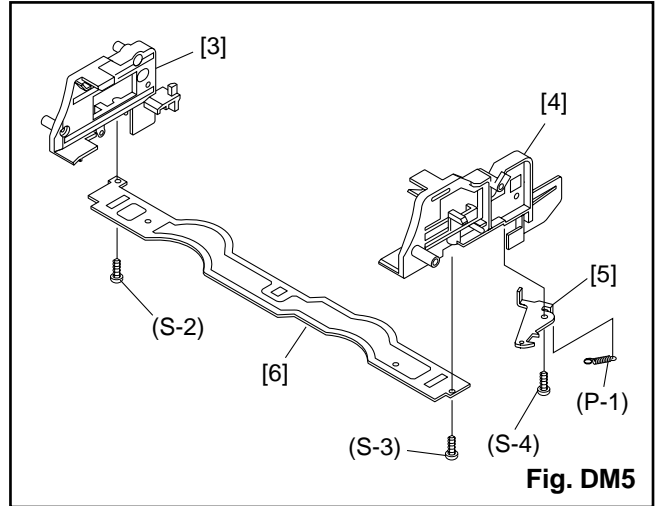


Fig. DM2

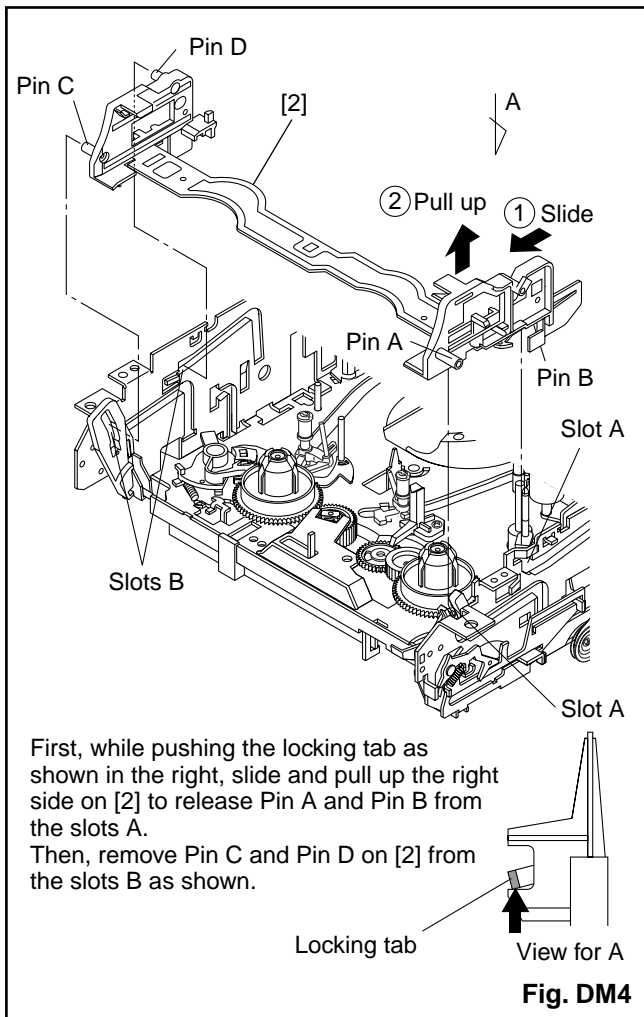


**Fig. DM3**

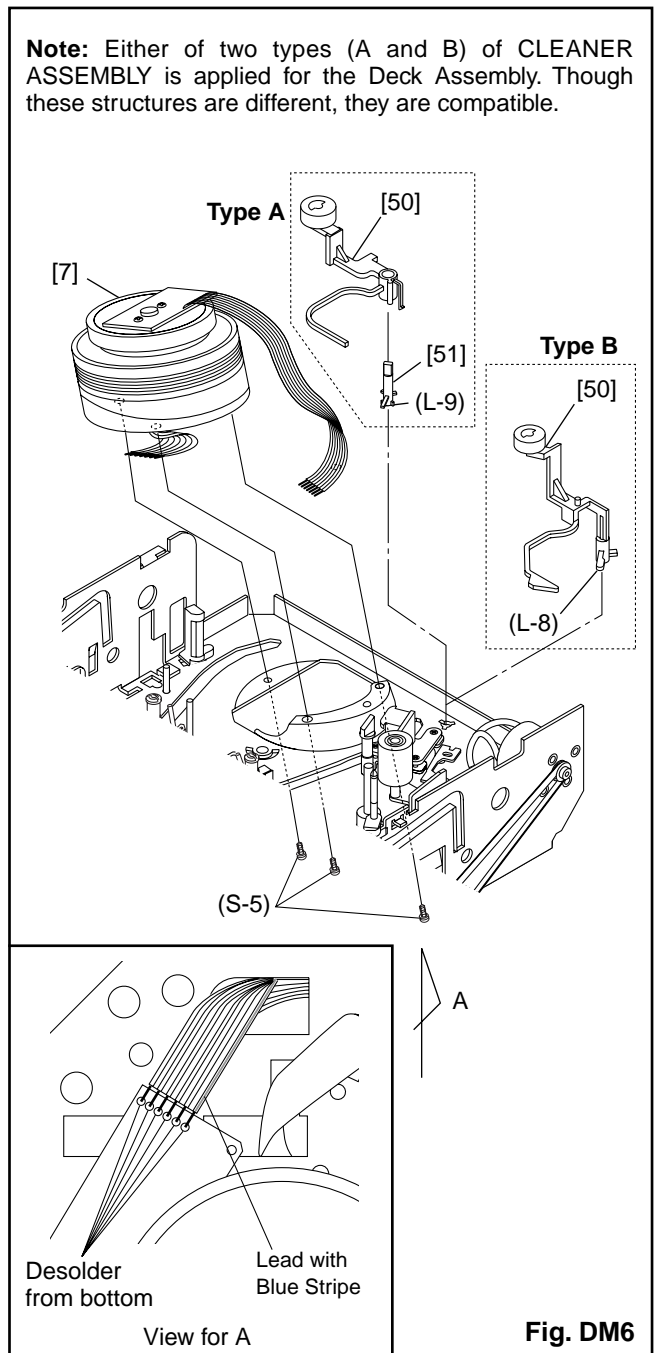


**Fig. DM5**

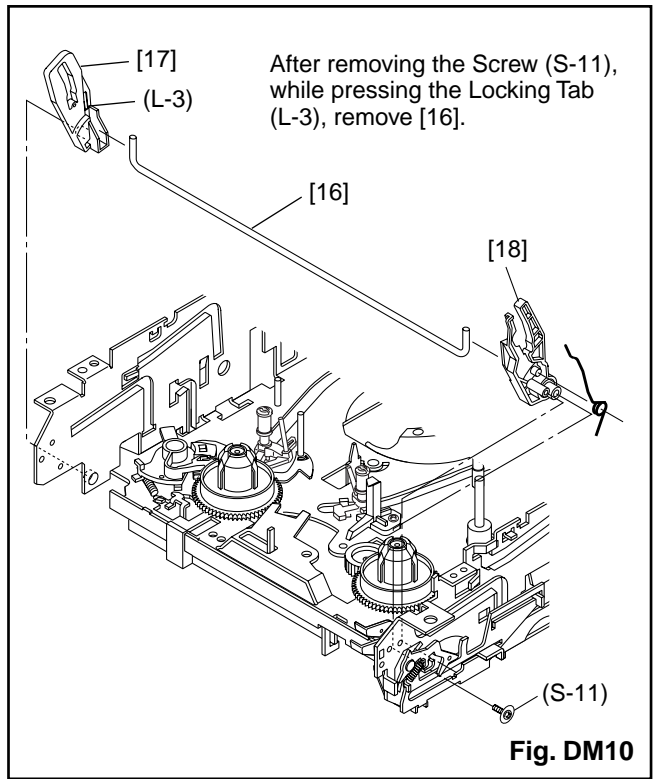
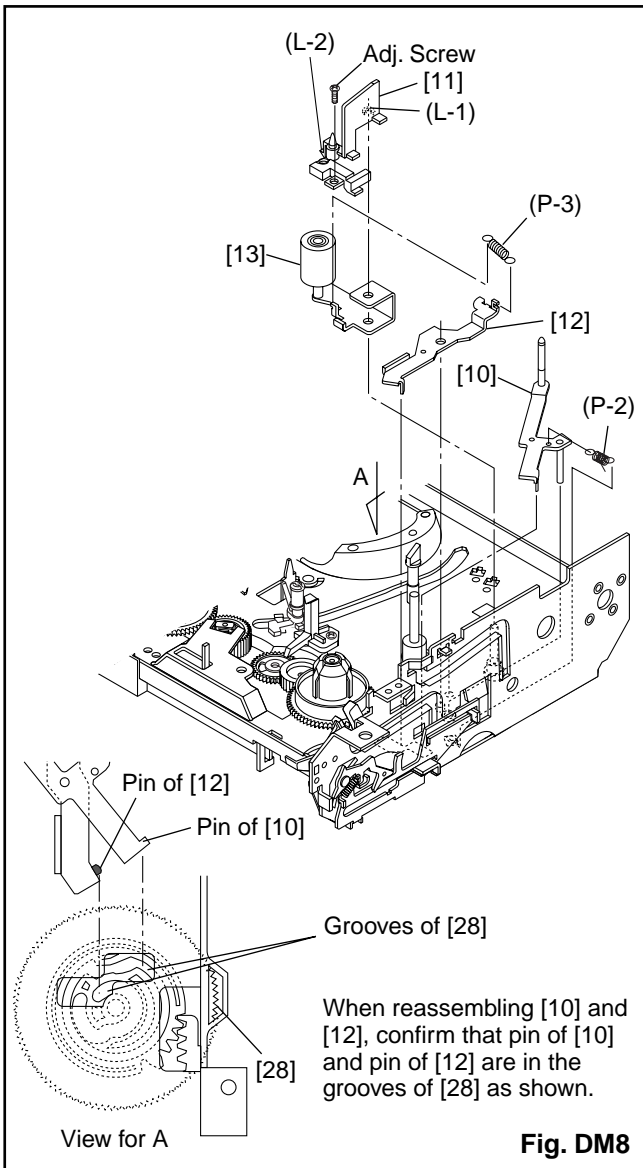
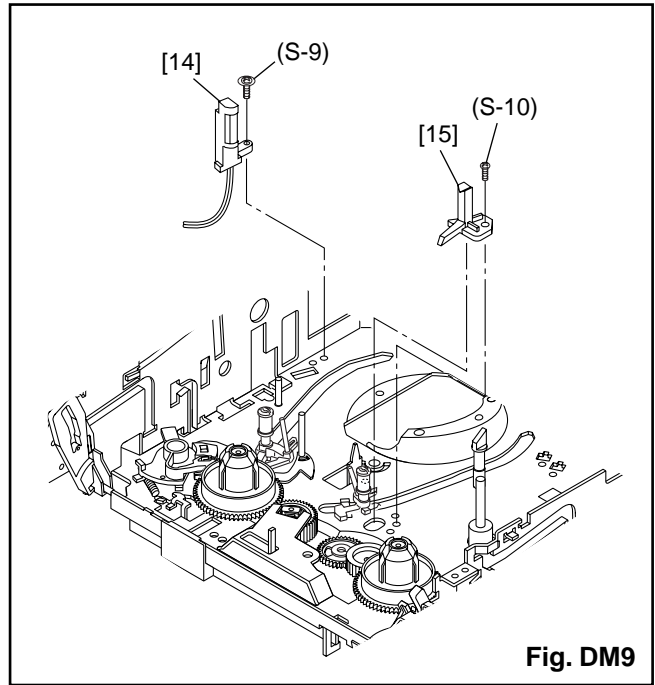
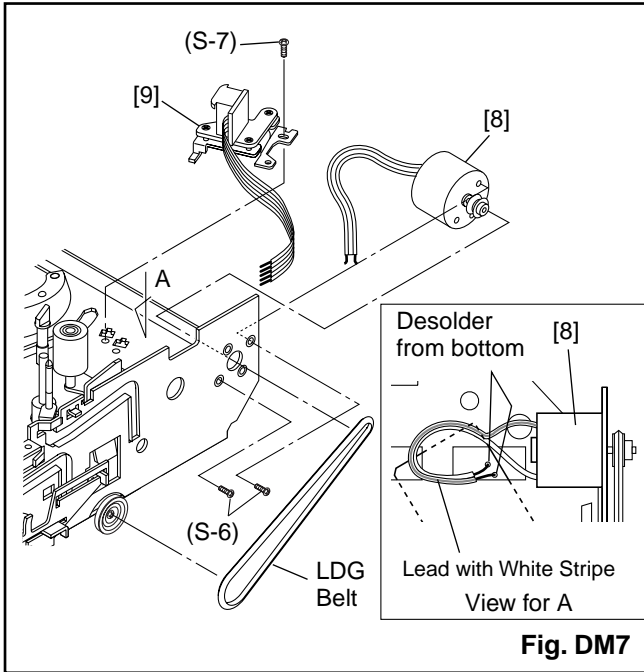
**Note:** Either of two types (A and B) of CLEANER ASSEMBLY is applied for the Deck Assembly. Though these structures are different, they are compatible.

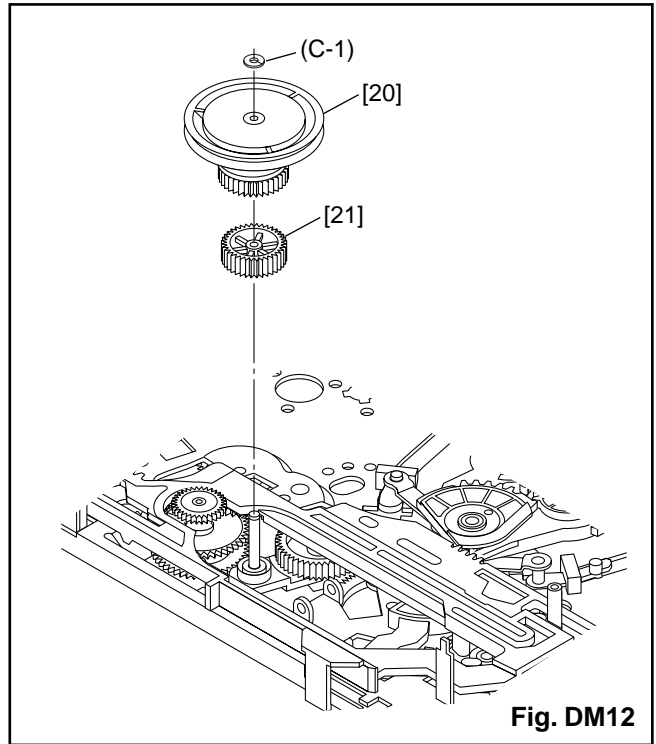
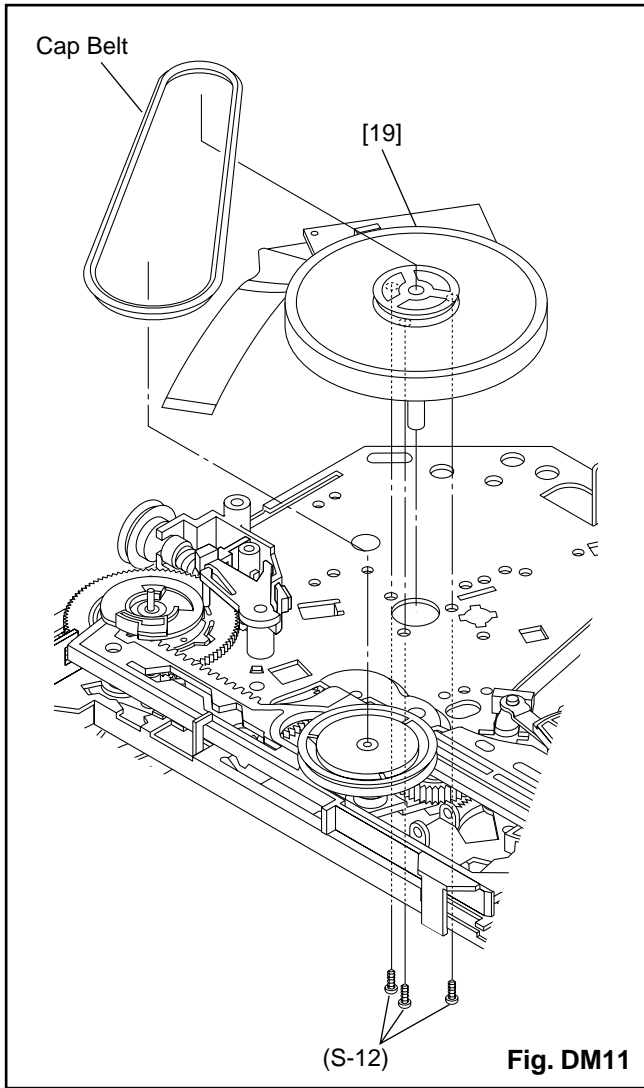


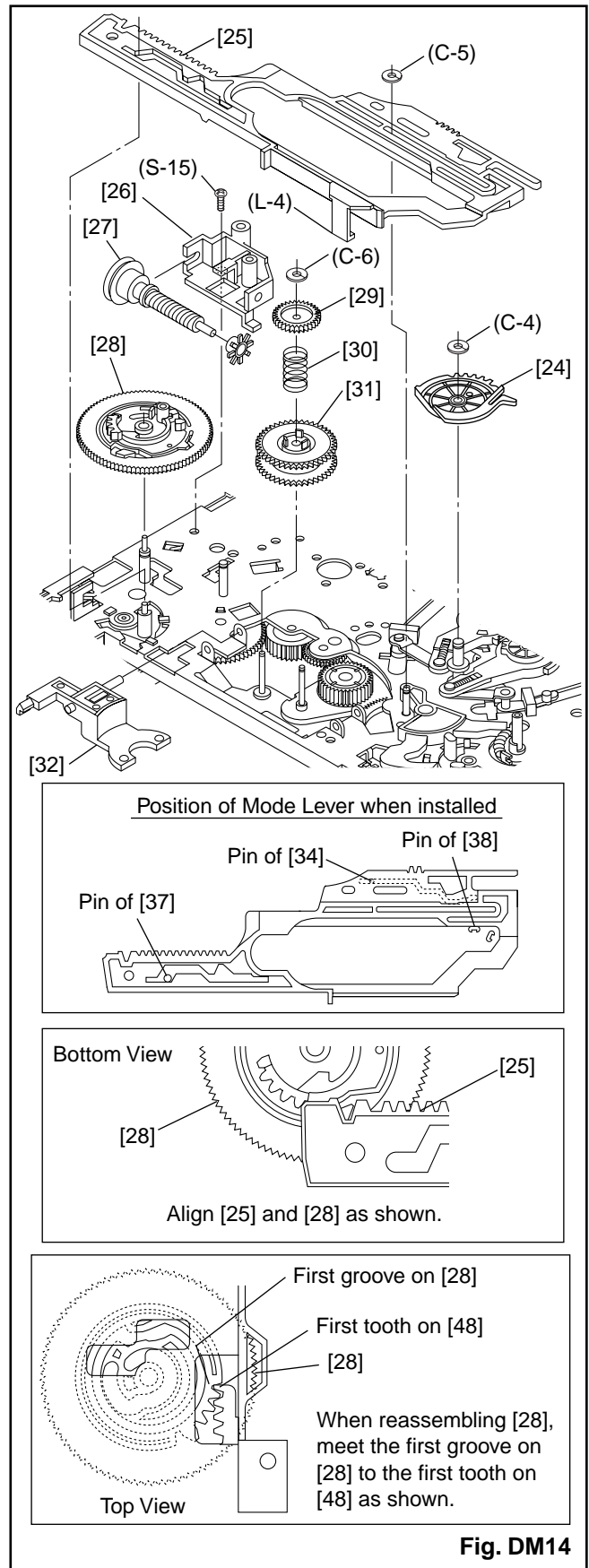
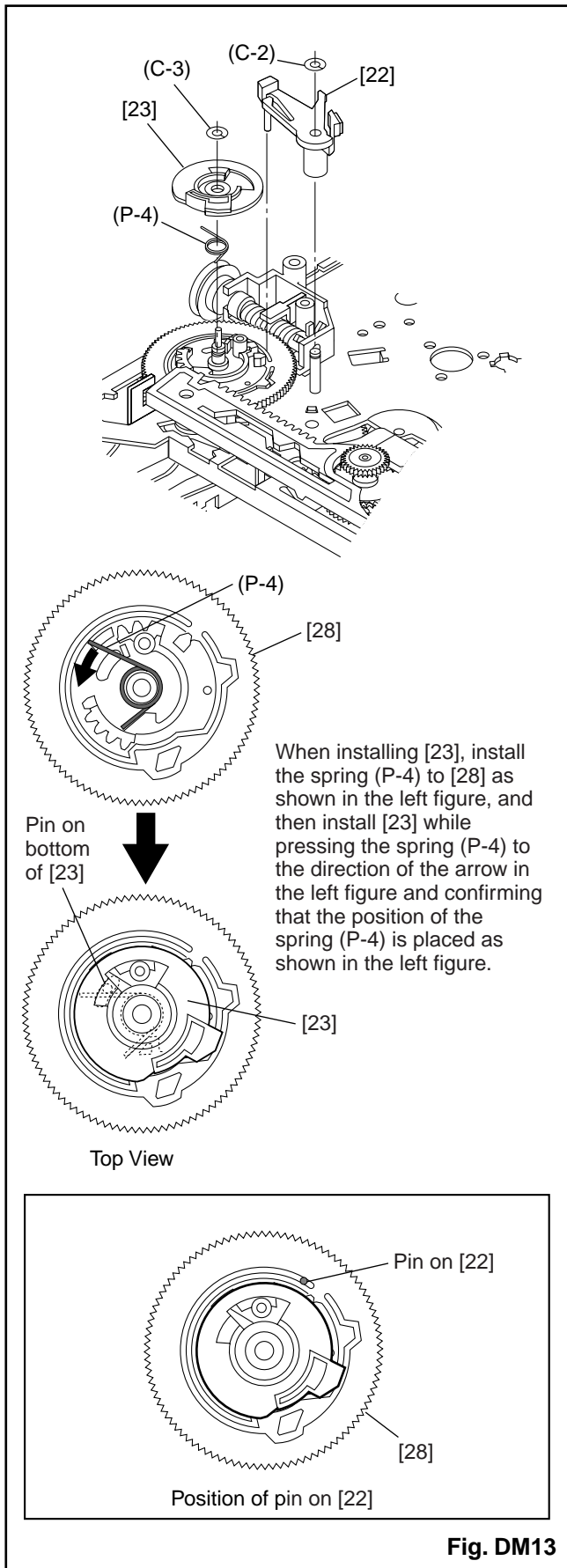
**Fig. DM4**

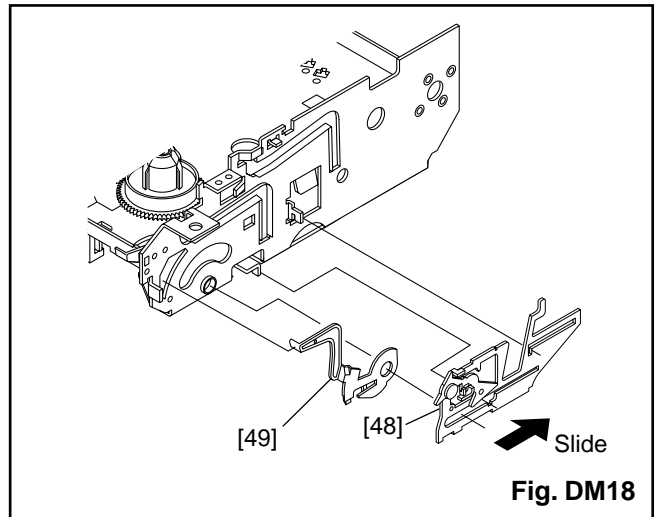
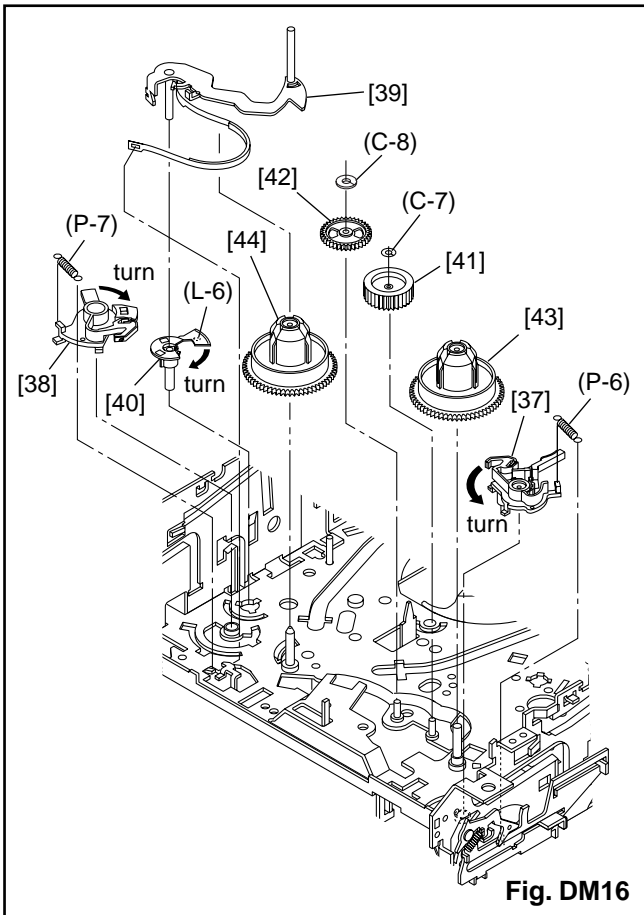
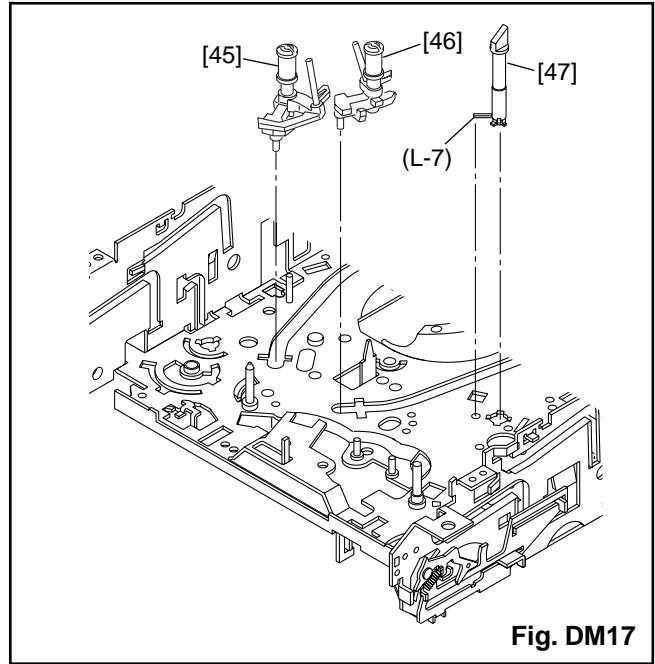
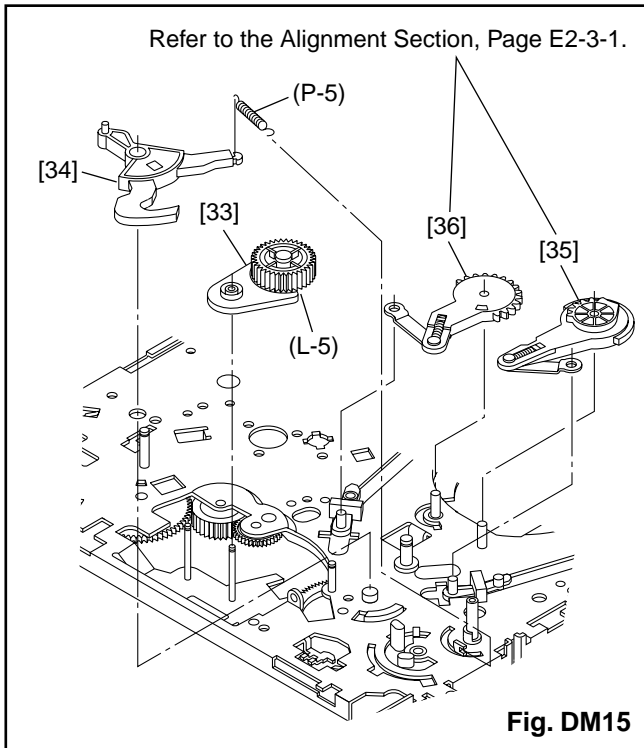


**Fig. DM6**









# ALIGNMENT PROCEDURES OF MECHANISM

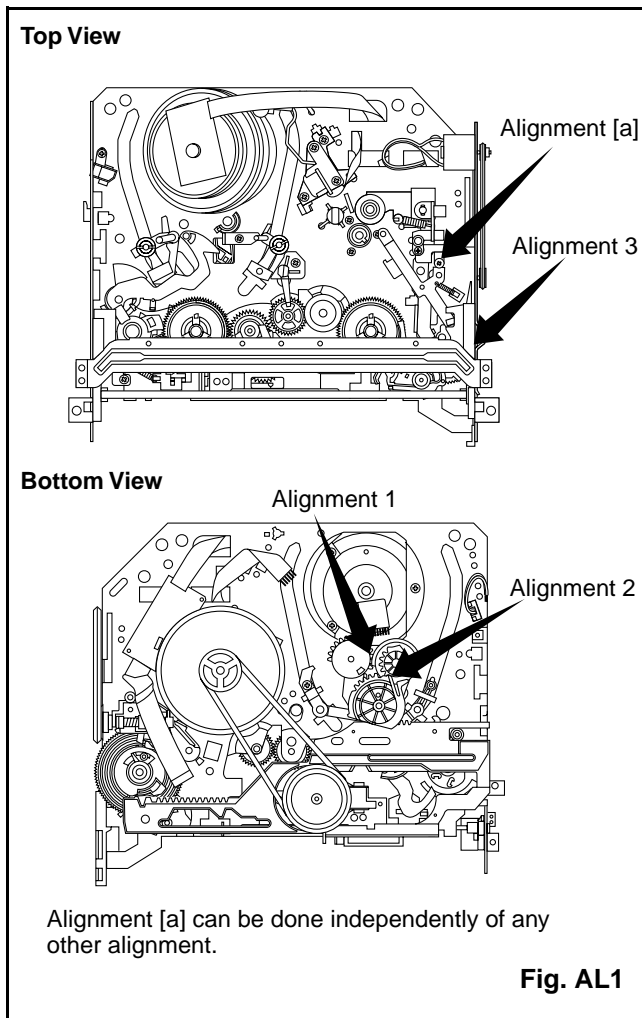
The following procedures describe how to align the individual gears and levers that make up the tape loading/unloading mechanism. Since information about the state of the mechanism is provided to the System Control Circuit only through the Mode Switch, it is essential that the correct relationship between individual gears and levers be maintained.

**All alignments are to be performed with the mechanism in Eject mode**, in the sequence given. Each procedure assumes that all previous procedures have been completed.

## IMPORTANT:

If any one of these alignments is not performed properly, even if off by only one tooth, the unit will unload or stop and it may result in damage to the mechanical or electrical parts.

## Alignment points in Eject Position



## Alignment 1

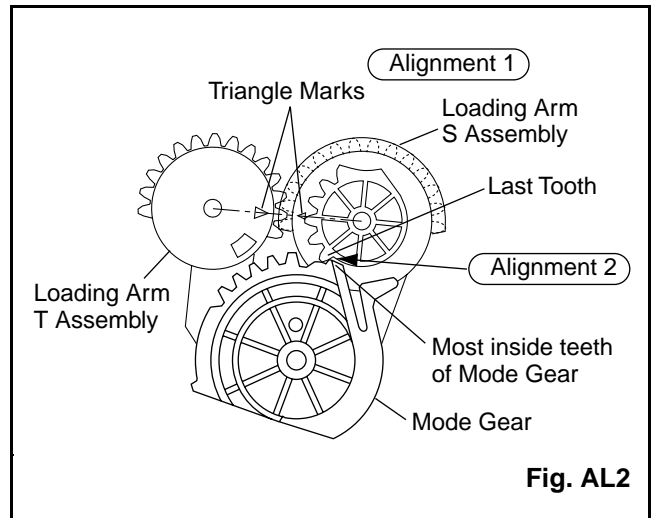
### Loading Arm, S and T Assembly

Install Loading Arm S and T Assembly so that their triangle marks point to each other as shown in Fig. AL2.

## Alignment 2

### Mode Gear

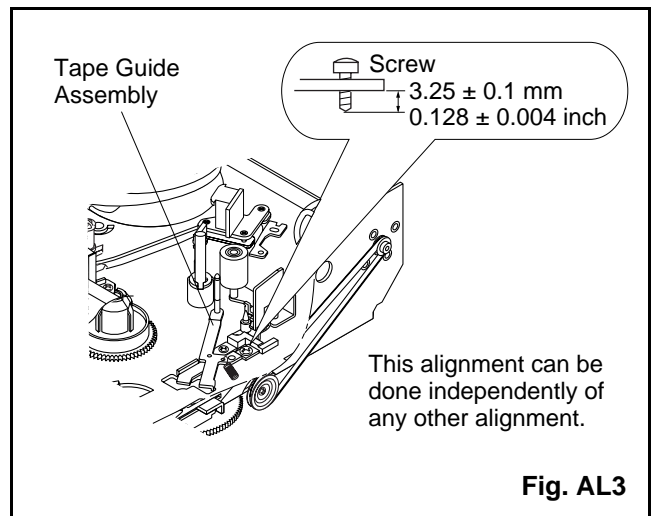
Keeping the two triangles pointing at each other, install the Loading Arm T Assembly so that the last tooth of the gear meets the most inside teeth of the Mode Gear. See Fig. AL2.



## Alignment [a]

### Tape Guide Assembly

Measurement of the screw must be as specified in Fig. AL3.

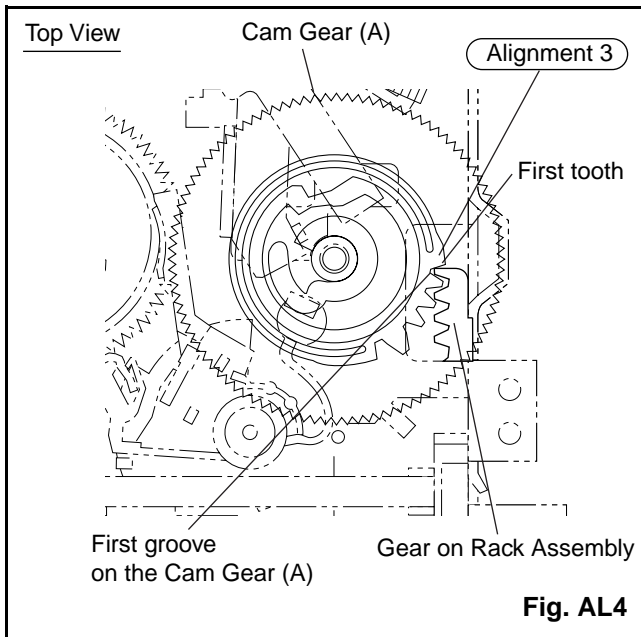




### Alignment 3

#### **Cam Gear (A), Rack Assembly**

Install the Rack Assembly so that the first tooth on the gear of the Rack Assembly meets the first groove on the Cam Gear (A) as shown in Fig. AL4.



# ELECTRICAL ADJUSTMENT INSTRUCTIONS

**General Note:** "CBA" is an abbreviation for "Circuit Board Assembly."

**NOTE:**

1. Electrical adjustments are required after replacing circuit components and certain mechanical parts. It is important to do these adjustments only after all repairs and replacements have been completed. Also, do not attempt these adjustments unless the proper equipment is available.
2. To perform these alignment / confirmation procedures, make sure that the tracking control is set in the center position: Press either "▼" or "▲" button on the remote control unit first, then the "PLAY" button (Front Panel only).

## Test Equipment Required

1. Oscilloscope: Dual-trace with 10:1 probe, V-Range: 0.001~50V/Div., F-Range: DC~AC-20MHz
2. Alignment Tape (MH-2)

## Head Switching Position Adjustment

**Purpose:**

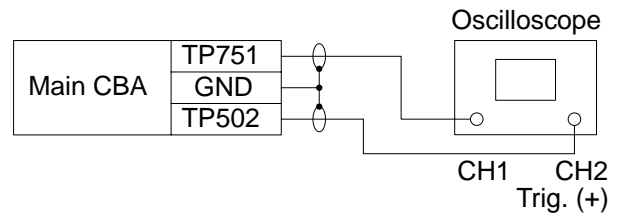
To determine the Head Switching point during playback.

**Symptom of Misadjustment:**

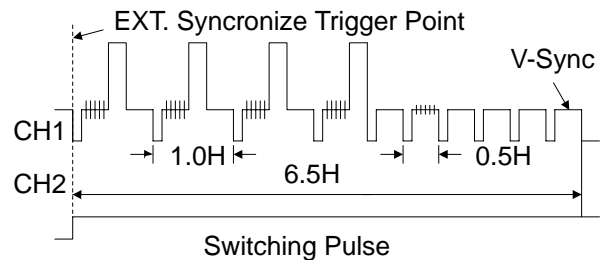
May cause Head Switching noise or vertical jitter in the picture.

Test point	Adj. Point	Mode	Input
TP751(V-OUT) TP504(RF-SW) GND	VR501 (Switching Point) (MAIN CBA)	PLAY (SP)	-----
Tape	Measurement Equipment	Spec.	
MH-2	Oscilloscope	6.5H±1H (412.7µs±60µs)	

**Connections of Measurement Equipment**



**Figure 1**

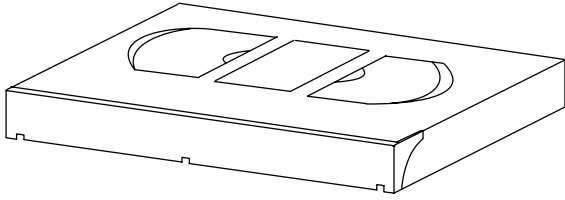


**Reference Notes:**

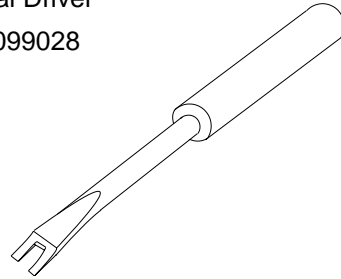
Play back the Alignment tape and adjust VR501 so that the V-sync front edge of the CH1 video output waveform is at the 6.5H(412.7µs) delayed position from the rising edge of the CH2 head switching pulse waveform.

# FIXTURE AND TAPE FOR ADJUSTMENT

1. Alignment Tape  
No. 7099052 (MH-2)



2. Special Driver  
No. 7099028



## How To Use The Fixtures And Tape

Item No.	Name	Part No.	Adjustment
1	Alignment Tape	7099052	<ul style="list-style-type: none"><li>● Head Switching Point</li><li>● Tape Interchangeability Alignment</li></ul>
2	Special Driver	7099028	<ul style="list-style-type: none"><li>● Guide Roller</li></ul>

# MECHANICAL ALIGNMENT PROCEDURES

Explanation of alignment for the tape to correctly run starts on the next page. Refer to the information below on this page if a tape gets stuck, for example, in the mechanism due to some electrical trouble of the unit.

## Service Information

### A. Method for Manual Tape Loading/Unloading

To load a cassette tape manually:

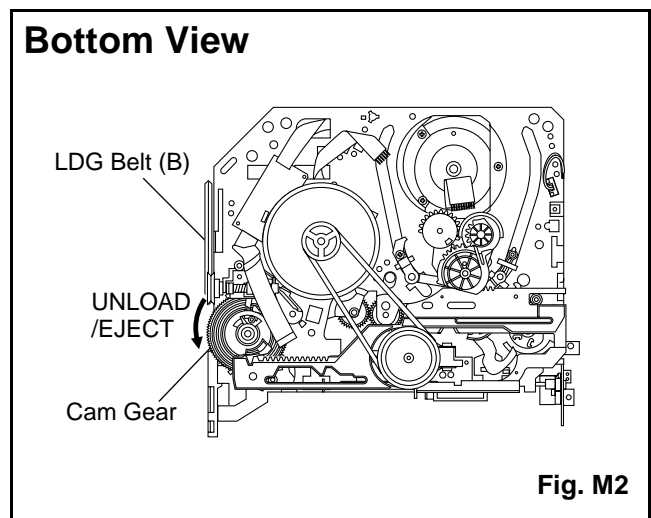
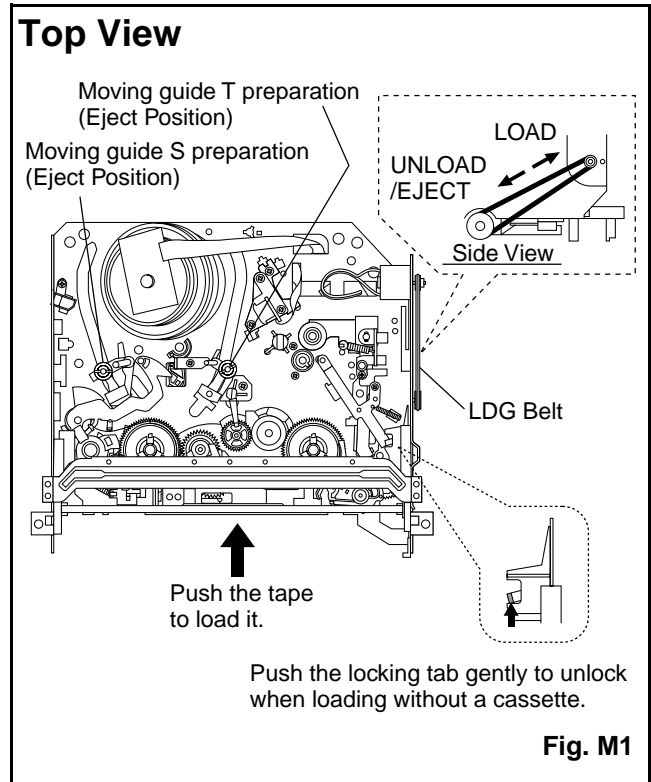
1. Disconnect the AC plug.
2. Remove the Top Case and Front Assembly.
3. Insert a cassette tape. Though the tape will not be automatically loaded, make sure that the cassette tape is all the way in at the inlet of the Cassette Holder. To confirm this, lightly push the cassette tape further in and see if the tape comes back out, by a spring motion, just as much as you have pushed in.
4. Turn the LDG Belt in the appropriate direction shown in Fig. M1 for a minute or two to complete this task.

To unload a cassette tape manually:

1. Disconnect the AC plug.
2. Remove the Top Case and Front Assembly.
3. Make sure that the Moving guide preparations are in the Eject Position.
4. Turn the LDG Belt in the appropriate direction shown in Fig. M1 until the Moving guide preparations come to the Eject Position. Stop turning when the preparations begin clicking or can not be moved further. However, the tape will be left wound around the cylinder.
5. Turn the LDG Belt in the appropriate direction continuously, and the cassette tape will be ejected. Allow a minute or two to complete this task.

### B. Method to place the Cassette Holder in the tape-loaded position without a cassette tape

1. Disconnect the AC Plug.
2. Remove the Top Case and Front Assembly.
3. Turn the LDG Belt in the appropriate direction shown in Fig. M1. Release the locking tabs shown in Fig. M1 and continue turning the LDG Belt until the Cassette Holder comes to the tape-loaded position. Allow a minute or two to complete this task.



# 1.Tape Interchangeability Alignment

Note:

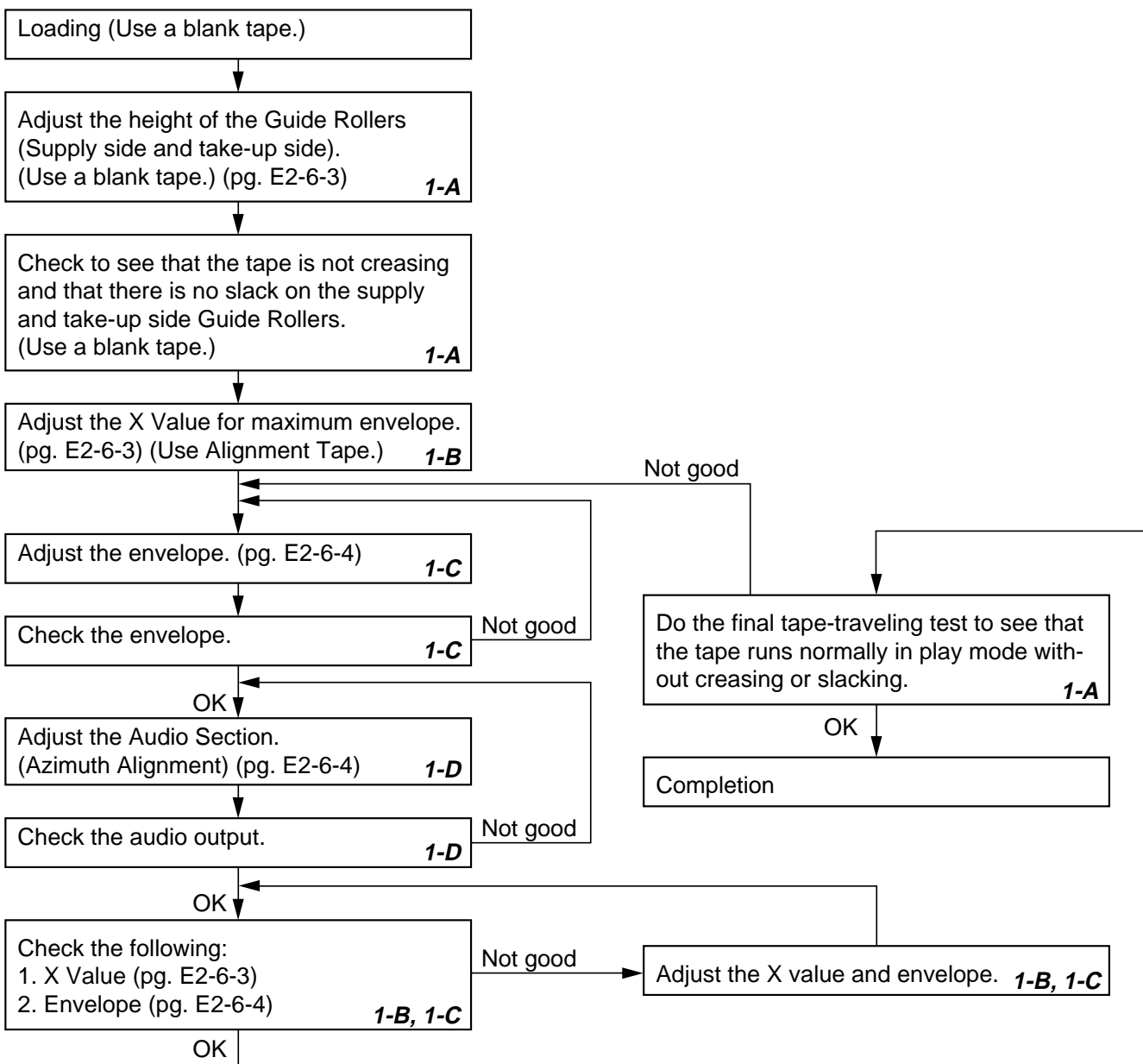
To do these alignment procedures, make sure that the Tracking Control Circuit is set to the center position every time a tape is loaded or unloaded. (Refer to page E2-6-4, procedure 1-C, step 2.)

## Equipment required:

- Dual Trace Oscilloscope
- VHS Alignment Tape (MH-2)
- Guide Roller Adj. Screwdriver
- X-Value Adj. Screwdriver

Note: Before starting this Mechanical Alignment, do all Electrical Adjustment procedures.

## Flowchart of Alignment for tape traveling



## 1-A. Preliminary/Final Checking and Alignment of Tape Path

### Purpose:

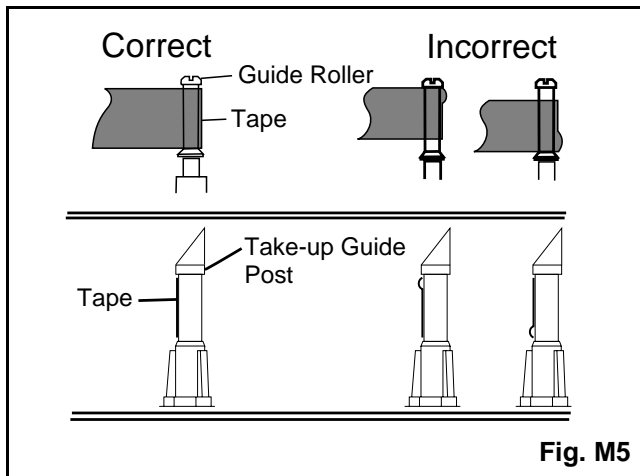
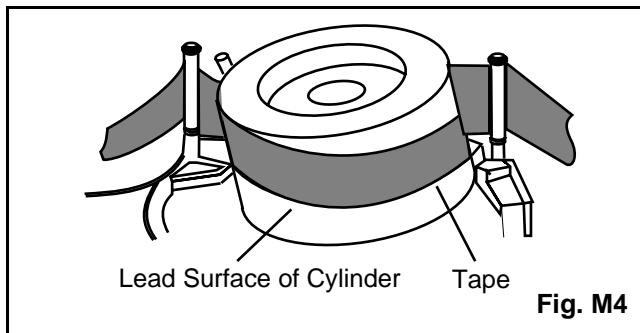
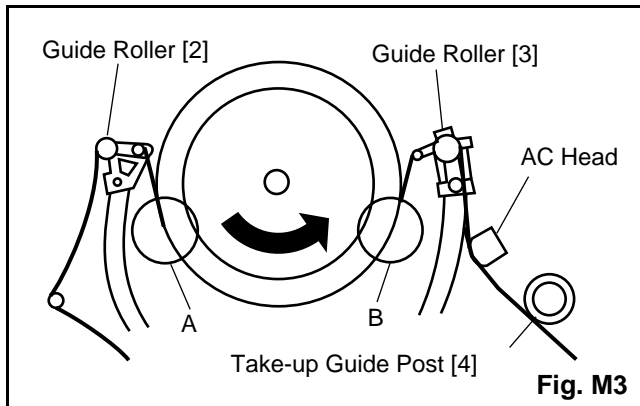
To make sure that the tape path is well stabilized.

### Symptom of Misalignment:

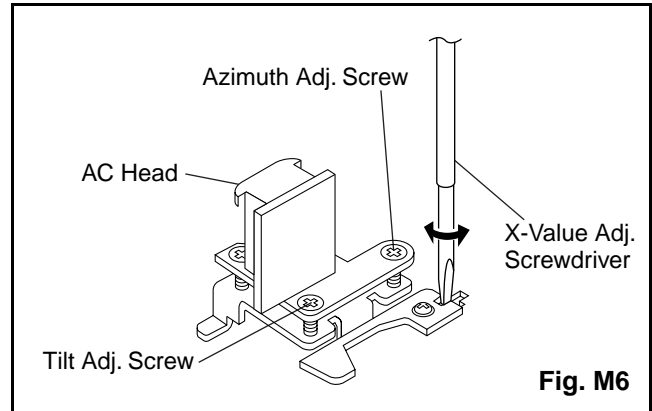
If the tape path is unstable, the tape will be damaged.

**Note:** Do not use an Alignment Tape for this procedure. If the unit is not correctly aligned, the tape may be damaged.

1. Play back a blank cassette tape and check to see that the tape runs without creasing at Guide Rollers [2] and [3], and at points A and B on the lead surface. (Refer to Fig M3 and M4.)
2. If creasing is apparent, align the height of the guide rollers by turning the top of Guide Rollers [2] and [3] with a Guide Roller Adj. Screwdriver. (Refer to Fig. M3 and M5.)



3. Check to see that the tape runs without creasing at Take-up Guide Post [4] or without snaking between Guide Roller [3] and AC Head. (Fig. M3 and M5)
4. If creasing or snaking is apparent, adjust the Tilt Adj. Screw of the AC Head. (Fig. M6)



## 1-B. X Value Alignment

### Purpose:

To align the Horizontal Position of the Audio/Control/ Erase Head.

### Symptom of Misalignment:

If the Horizontal Position of the Audio/Control/Erase Head is not properly aligned, maximum envelope cannot be obtained at the Neutral position of the Tracking Control Circuit.

1. Connect the oscilloscope to TP301 (C-PB) and TP503 (CTL) on the Main CBA. Use TP504 (RF-SW) as a trigger. Connect the oscilloscope to TP301 (C-PB) and TP503 (CTL) on the Main CBA. Use TP504 (RF-SW) as a trigger.
2. Play back the Gray Scale of the Alignment Tape (MH-2) and confirm that the PB FM signal is present.
3. Set the Tracking Control Circuit to the center position by pressing CH UP button then "PLAY" button on the unit. (Refer to note on bottom of page E2-6-4.)
4. Use the X-Value Adj. Screwdriver so that the PB FM signal at TP301 (C-PB) is maximum. (Fig. M6)
5. Press CH UP button on the unit until the CTL waveform has shifted by approx. +2ms. Make sure that the envelope is simply attenuated (shrinks in height) during this process so that you will know the envelope has been at its peak.

6. Press CH DOWN button on the unit until the CTL waveform has shifted from its original position (not the position achieved in step 5, but the position of CTL waveform in step 4) by approximately -2ms. Make sure that the envelope is simply attenuated (shrinks in height) once CTL waveform passes its original position and is further brought in the minus direction.
7. Set the Tracking Control Circuit to the center position by pressing CH UP button and then "PLAY" button.

### 1-C. Checking/Adjustment of Envelope Waveform

**Purpose:**

To achieve a satisfactory picture and precise tracking.

**Symptom of Misalignment:**

If the envelope output is poor, noise will appear in the picture. The tracking will then lose precision and the playback picture will be distorted by any slight variation of the Tracking Control Circuit.

1. Connect the oscilloscope to TP301 (C-PB) on the Main CBA. Use TP504 (RF-SW) as a trigger.
2. Play back the Gray Scale on the Alignment Tape (MH-2). Set the Tracking Control Circuit to the center position by pressing CH UP button and then "PLAY" button on the unit. Adjust the height of Guide Rollers [2] and [3] (Fig. M3, Page E2-6-3) watching the oscilloscope display so that the envelope becomes as flat as possible. To do this adjustment, turn the top of the Guide Roller with the Guide Roller Adj. Screwdriver.
3. If the envelope is as shown in Fig. M7, adjust the height of Guide Roller [2] (Refer to Fig. M3) so that the waveform looks like the one shown in Fig. M9.
4. If the envelope is as shown in Fig. M8, adjust the height of Guide Roller [3] (Refer to Fig. M3) so that the waveform looks like the one shown in Fig. M9.
5. When Guide Rollers [2] and [3] (Refer to Fig. M3) are aligned properly, there is no envelope drop either at the beginning or end of track as shown in Fig. M9.

Note: Upon completion of the adjustment of Guide Rollers [2] and [3] (Refer to Fig. M3), check the X Value by pushing the CH UP or DOWN buttons alternately, to check the symmetry of the envelope. Check the number of pushes to ensure center position. The number of pushes CH UP button to achieve 1/2 level of envelope should match the number of pushes CH DOWN button from center. If required, redo the "X Value Alignment."

### 1-D. Azimuth Alignment of Audio/Control/ Erase Head

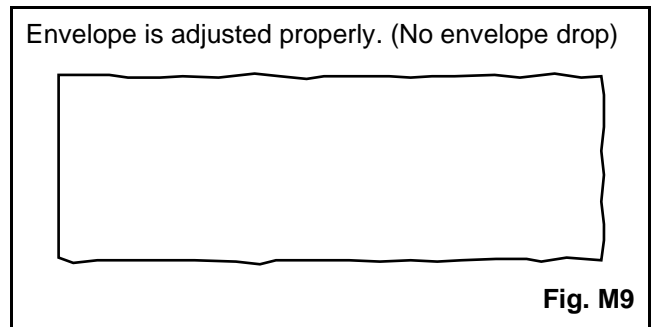
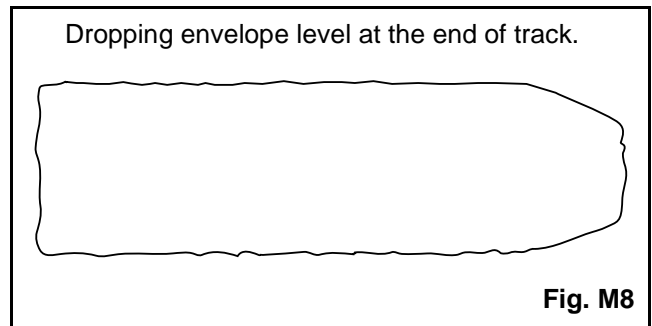
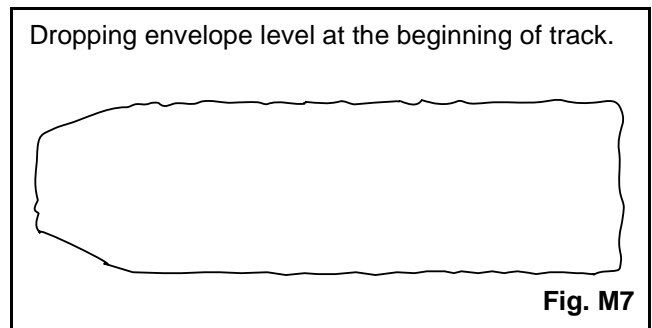
**Purpose:**

To correct the Azimuth alignment so that the Audio/Control/Erase Head meets tape tracks properly.

**Symptom of Misalignment:**

If the position of the Audio/Control/Erase Head is not properly aligned, the Audio S/N Ratio or Frequency Response will be poor.

1. Connect the oscilloscope to the audio output jack on the rear side of the deck.
2. Play back the alignment tape (MH-2) and confirm that the audio signal output level is 8kHz.
3. Adjust Azimuth Adj. Screw so that the output level on the AC Voltmeter or the waveform on the oscilloscope is at maximum. (Fig. M6)



# STANDARD MAINTENANCE

## Service Schedule of Components

h: Hours ○: Check ●: Change

Deck		Periodic Service Schedule			
Ref.No.	Part Name	1,000 h	2,000 h	3,000 h	4,000 h
B2	Cylinder Assembly	○	●	○	●
B3	Loading Motor Assembly			●	
B8	Pulley Assembly		●		●
B27	Tension Lever Sub Assembly		●		●
B31	AC Head Assembly			●	
B573,B574	Reel S, Reel T			●	
B37	Capstan Motor		●		●
B52	Cap Belt		●		●
*B73	FE Head			●	
B133	Idler Assembly		●		●
B410	Pinch Arm (A) Assembly		●		●
B414	M Brake S Assembly		●		●
B416	M Brake T Assembly		●		●
B525	LDG Belt		●		●

### Notes:

- 1.Clean all parts for the tape transport (Upper Drum with Video Head / Pinch Roller / Audio Control Head / Full Erase Head) using 90% Isopropyl Alcohol.
  - 2.After cleaning the parts, do all DECK ADJUSTMENTS.
  - 3.For the reference numbers listed above, refer to Deck Exploded Views.
- \* B73 ----- Recording Model only



## Cleaning

### Cleaning of Video Head

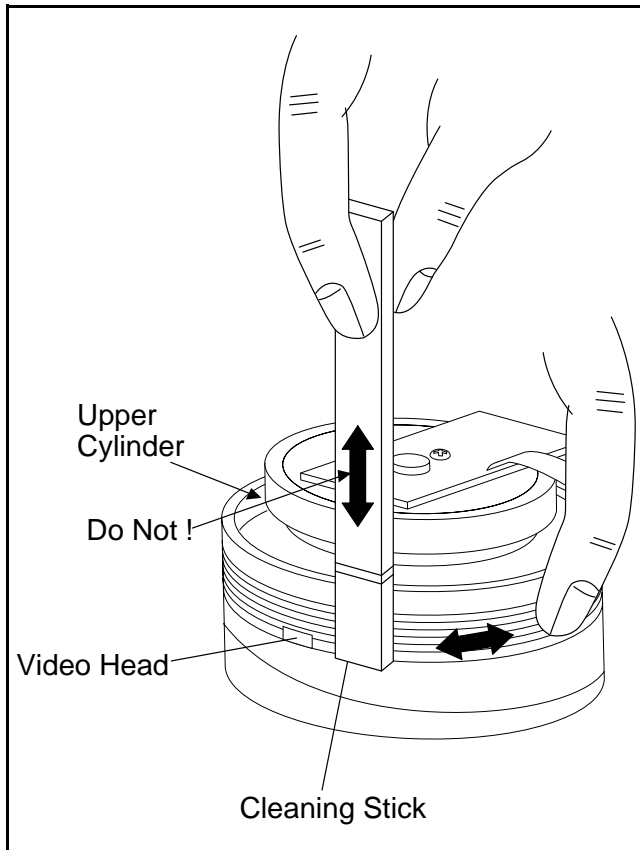
Clean the head with a head cleaning stick or chamois cloth.

#### Procedure

1. Remove the top cabinet.
2. Put on a glove (thin type) to avoid touching the upper and lower drum with your bare hand.
3. Put a few drops of 90% Isopropyl alcohol on the head cleaning stick or on the chamois cloth and, by slightly pressing it against the head tip, turn the upper drum to the right and to the left.

#### Notes:

1. The video head surface is made of very hard material, but since it is very thin, avoid cleaning it vertically.
2. Wait for the cleaned part to dry thoroughly before operating the unit.
3. Do not reuse a stained head cleaning stick or a stained chamois cloth.



### Cleaning of Audio Control Head

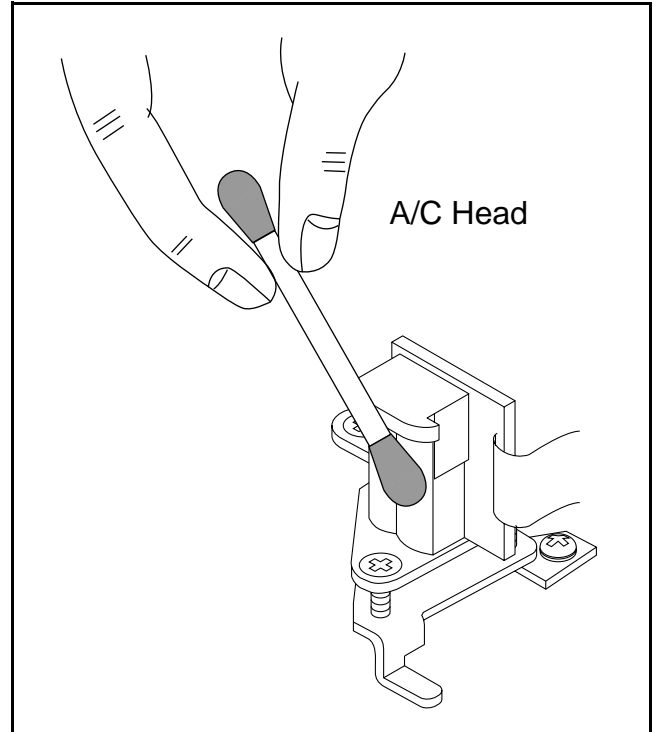
Clean the head with a cotton swab.

#### Procedure

1. Remove the top cabinet.
2. Dip the cotton swab in 90% isopropyl alcohol and clean the audio control head. Be careful not to damage the upper drum and other tape running parts.

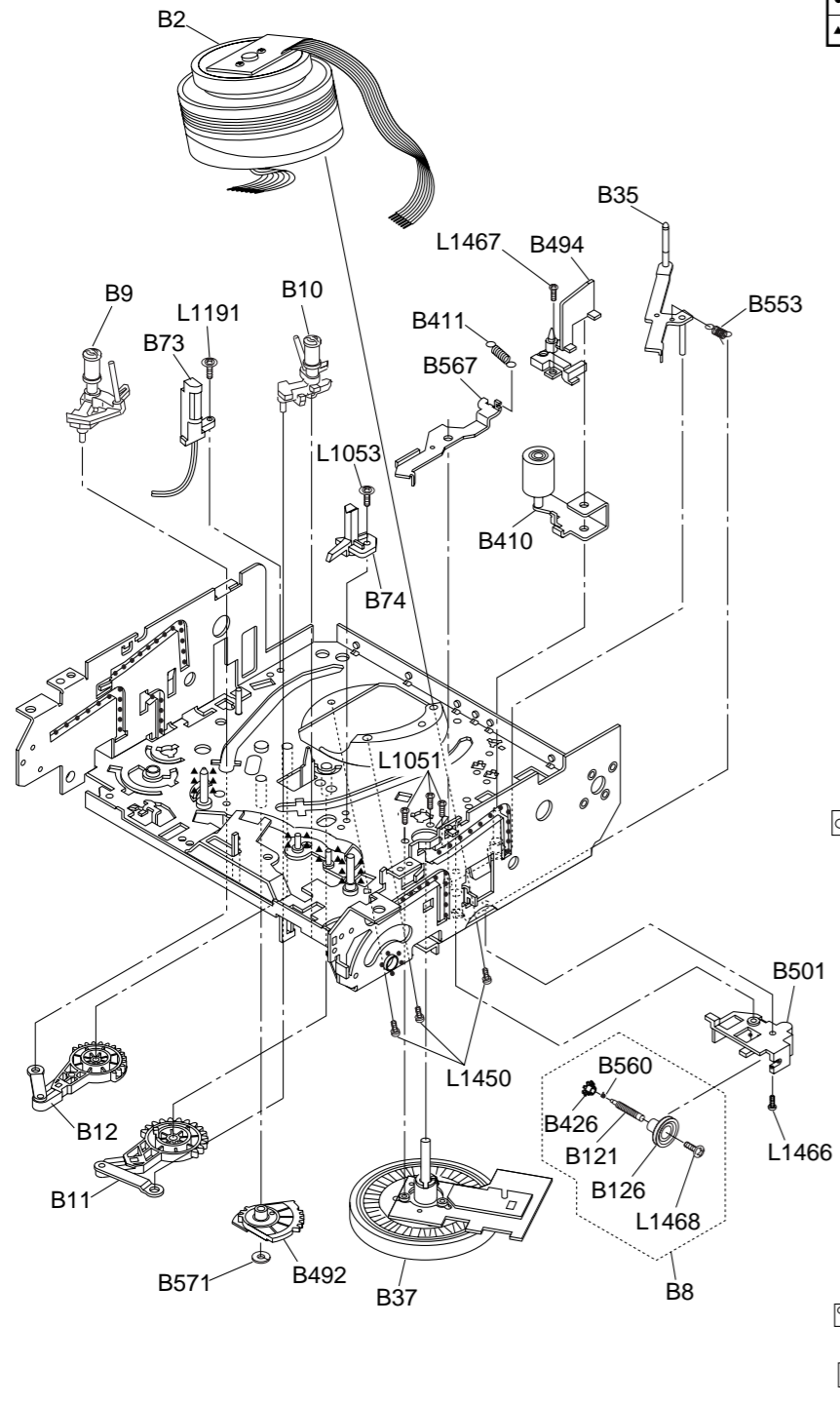
#### Notes:

1. Avoid cleaning the audio control head vertically.
2. Wait for the cleaned part to dry thoroughly before operating the unit or damage may occur.

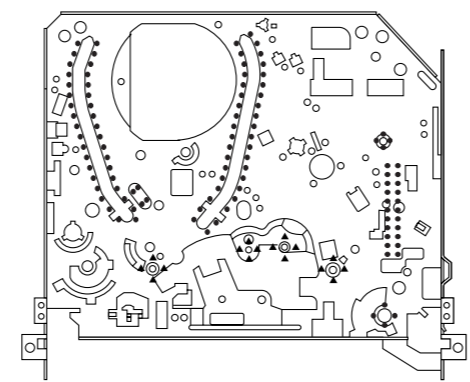




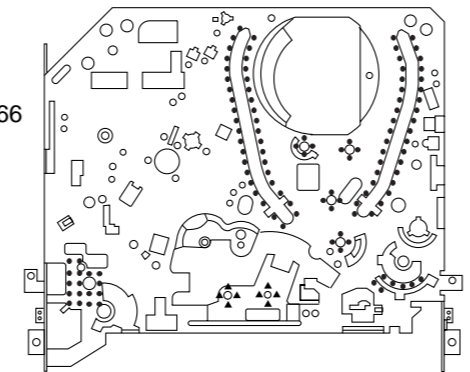
## Deck Mechanism View 1



Mark	Description
•••••	Floil G-374G (Blue grease)
▲▲▲▲▲	SLIDUS OIL #150



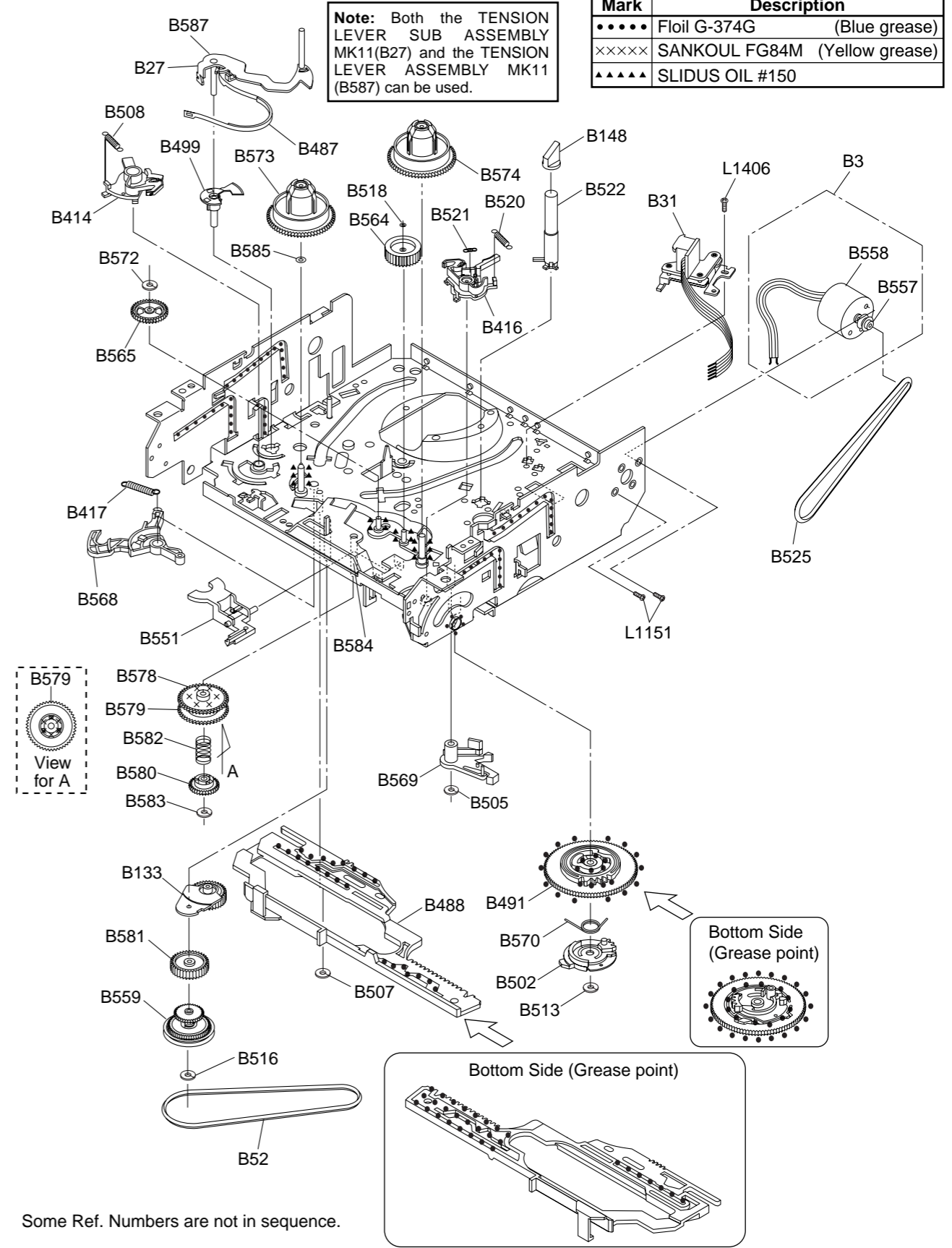
Chassis Assembly  
Top View (Lubricating Point)



Chassis Assembly  
Bottom View (Lubricating Point)

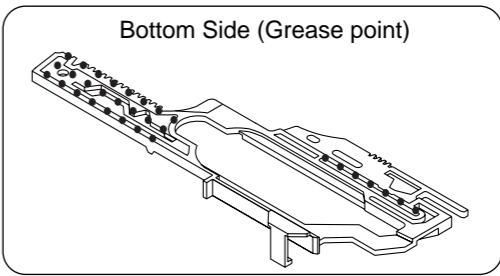
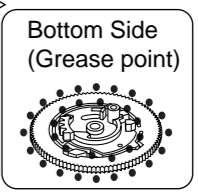
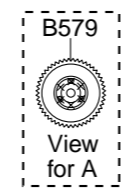
Some Ref. Numbers are not in sequence.

## Deck Mechanism View 2



Mark	Description
•••••	Floil G-374G (Blue grease)
xxxxx	SANKOUL FG84M (Yellow grease)
▲▲▲▲▲	SLIDUS OIL #150

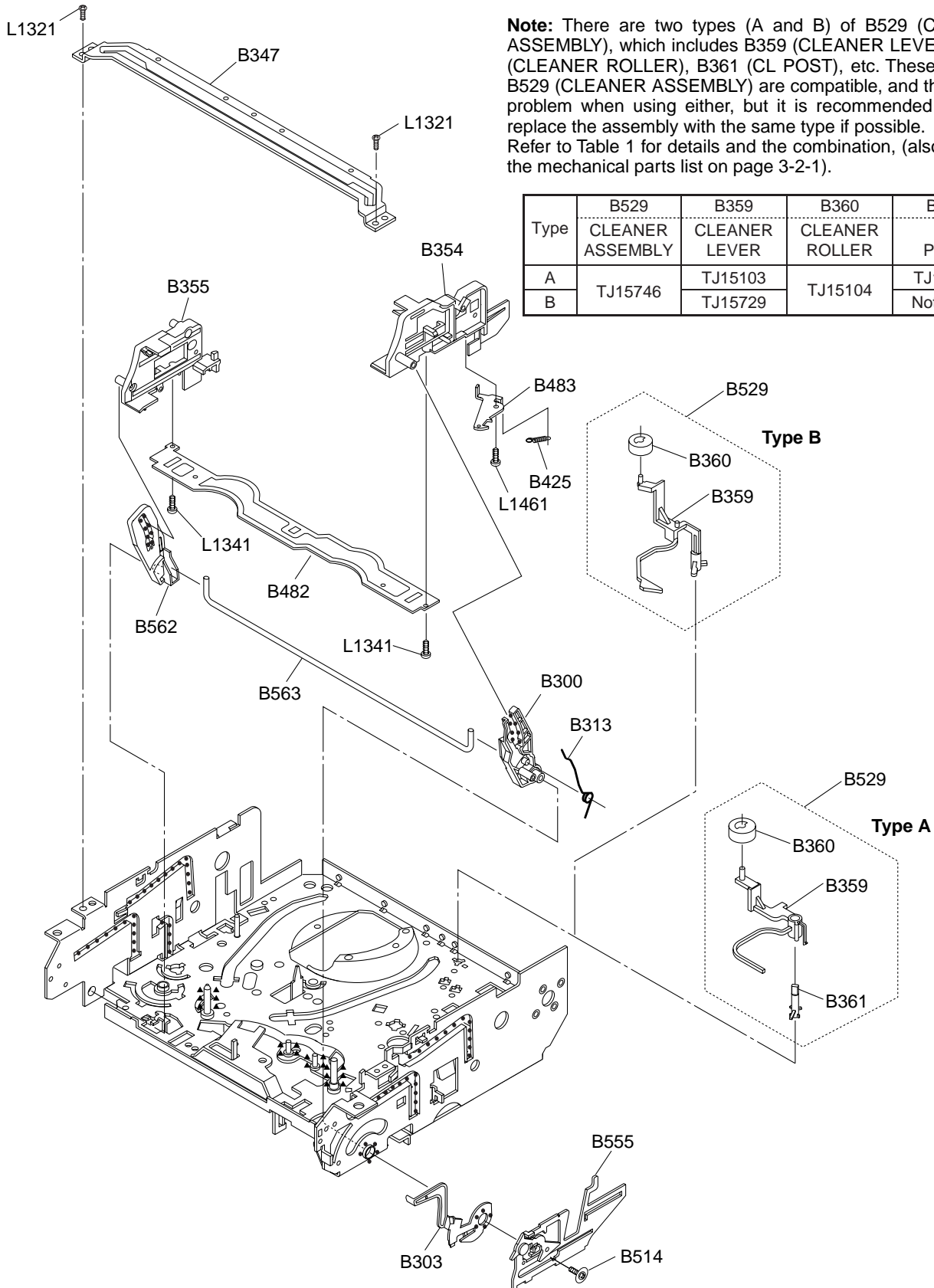
Note: Both the TENSION LEVER SUB ASSEMBLY MK11(B27) and the TENSION LEVER ASSEMBLY MK11 (B587) can be used.



Some Ref. Numbers are not in sequence.

# Deck Mechanism View 3

Mark	Description
•••••	Floil G-374G (Blue grease)
▲▲▲▲▲	SLIDUS OIL #150



**Note:** There are two types (A and B) of B529 (CLEANER ASSEMBLY), which includes B359 (CLEANER LEVER), B360 (CLEANER ROLLER), B361 (CL POST), etc. These types of B529 (CLEANER ASSEMBLY) are compatible, and there is no problem when using either, but it is recommended that you replace the assembly with the same type if possible. Refer to Table 1 for details and the combination, (also, refer to the mechanical parts list on page 3-2-1).

Type	B529 CLEANER ASSEMBLY	B359 CLEANER LEVER	B360 CLEANER ROLLER	B361 CL POST
A	TJ15746	TJ15103	TJ15104	TJ15105
B	TJ15746	TJ15729	TJ15104	Not Used

Some Ref. Numbers are not in sequence.

# REPLACEMENT PARTS LIST

## Mechanical Parts List

SYMBOL-NO	P-NO	DESCRIPTION	SYMBOL-NO	P-NO	DESCRIPTION
<b>MECHANISM SECTION</b>			B52	TJ15161	CAP BELT
A1X	TJ16231	FRONT ASSEMBLY [DV-PF2E(UK)]	B73	TS17499	FE HEAD
A1X	TJ16232	FRONT ASSEMBLY [DV-PF2E]	B74	TJ15163	PRISM
A2	TJ15941	TOP COVER	B121	TJ15982	WORM
A4	TJ16233	PANEL, REAR [DV-PF2E(UK)]	B126	TJ15983	PULLEY
A4	TJ16234	PANEL, REAR [DV-PF2E]	B133	TJ15288	IDLER ASSEMBLY
A6	TS17312	INSULATOR ASSEMBLY	B148	TE12612	TG CAP
A20	TS17313	TRAY ASSEMBLY	B300	TJ15169	CASSETTE DRIVE LEVER (R)
A29	TJ15943	FOOT	B303	TJ15986	F DOOR OPENER
△ AC1001	TE15021	AC CORD [DV-PF2E(UK)]	B313	TJ15172	CASSETTE DRIVE SPRING
△ AC1001	TE15022	AC CORD [DV-PF2E]	B347	TJ15987	GUIDE HOLDER (A)
1B2	TS17001	DVD MECHA	B354	TJ15988	SLIDER (R)
2B1	TJ15944	DECK PEDESTAL	B355	TJ15989	SLIDER (L)
2B2	TJ15945	TOP BRACKET	B359	TJ15103	CLEANER LEVER [Type A]
2B3	TJ15946	SIDE BRACKET	B359	TJ15729	CLEANER LEVER [Type B]
2B6	TJ15944	DECK PEDESTAL	B360	TJ15104	CLEANER ROLLER
2B11	TJ16237	SHIELD ASSEMBLY	B361	TJ15105	CL POST
2B13	TE13012	BUSH, LED(E)	B410	TS17511	PINCH ARM (A) ASSEMBLY
2B15	TJ15122	BUSH, LED(F)	B411	TJ15181	PINCH SPRING
2B33	TJ15971	HEATSINK	B414	TJ16238	BRAKE (S) ASSEMBLY
2B40	TJ16235	INSULATOR	B416	TS17513	BRAKE (T) ASSEMBLY
2B41	TJ16236	BRACKET	B417	TJ16171	TENSION SPRING
2L021	TJ15951	SCREW	B425	TJ15185	LOCK LEVER SPRING
2L022	TJ15952	SCREW (3X8)	B426	TJ15186	KICK PULLEY
2L023	TJ10176	SCREW (M3X6)	B482	TJ15992	CASSETTE PLATE
2L031	TJ10176	SCREW (M3X6)	B483	TJ15292	LOCK LEVER
2L032	TJ10176	SCREW (M3X6)	B487	TJ15293	BAND BRAKE
2L034	TJ10176	SCREW (M3X6)	B488	TJ16239	MODE LEVER
2L035	TJ15953	SCREW (M3X8)	B491	TJ15994	CAM GEAR (A)
2L036	TJ15954	SCREW (M3X8)	B492	TJ15995	MODE GEAR
2L037	TJ10176	SCREW (M3X6)	B494	TJ15996	DOOR OPENER (B)
2L041	TJ16023	SCREW (M3X5)	B499	TJ15196	LEVER HOLDER (T)
2L051	TJ10177	SCREW (3X8)	B501	TJ15997	WORM HOLDER
2L052	TJ10177	SCREW (3X8)	B502	TJ15198	CAM GEAR(B)
2L053	TJ15956	SCREW (3X8)	B505	TJ15998	WASHER
2L054	TJ10177	SCREW (3X8)	B507	TJ14034	WASHER
2L062	TJ15892	SCREW (M3X8)	B508	TJ16241	BRAKE SPRING (S)
2L071	TJ10119	SCREW (M3X10)	B513	TJ15201	WASHER
B2	TS17693	CYLINDER ASSEMBLY	B514	TJ15202	SCREW RACK
B3	TS17442	LOADING MOTOR ASSEMBLY	B516	TJ14034	WASHER
B8	TS17443	PULLEY ASSEMBLY	B518	TJ15203	WASHER
B9	TJ15152	MOVING GUIDE (S)	B520	TJ16033	BRAKE SPRING (T)
B10	TJ15153	MOVING GUIDE (T)	B521	TJ15209	SOFT SPRING
B11	TS17444	LOADING ARM (T) ASSEMBLY	B522	TJ15206	TG POST
B12	TS17712	LOADING ARM (S) ASSEMBLY	B525	TJ16001	LDG BELT
B27	TS17446	TENSION LEVER SUB ASSEMBLY	B529	TJ15746	CLEANER ASSEMBLY
B31	TS17447	AC HEAD	B551	TJ15301	FF ARM
B35	TS17448	TAPE GUIDE	B553	TJ16003	REV SPRING
B37	TJ16031	CAPSTAN MOTOR	B555	TS17713	RACK ASSEMBLY
			B557	TJ15215	MOTOR PULLEY

SYMBOL-NO	P-NO	DESCRIPTION	SYMBOL-NO	P-NO	DESCRIPTION
B558	TJ16004	LOADING MOTOR			
B559	TS17515	CLUTCH ASSEMBLY			
B560	TJ15303	KICK SPRING			
B562	TJ15221	CASSETTE DRIVE LEVER (L)			
B563	TJ15222	SLIDER SHAFT			
B564	TJ16034	M GEAR			
B565	TJ16005	SENSOR GEAR			
B567	TJ15226	PINCH ARM (B)			
B568	TJ15304	BT ARM			
B569	TJ16006	CAM HOLDER			
B570	TJ16035	CAM RACK SPRING			
B571	TJ10229	WASHER			
B572	TJ15203	WASHER			
B573	TJ16007	REEL (S)			
B574	TJ16008	REEL (T)			
B578	TJ15306	TR GEAR (A)			
B579	TJ15307	TR GEAR (B)			
B580	TJ16036	TR GEAR (C)			
B581	TJ16172	CENTER GEAR			
B582	TJ15311	TR GEAR SPRING			
B583	TJ14034	REEL WASHER			
B584	TJ15312	TR GEAR SHAFT			
B585	TJ16009	WASHER			
B587	TS17714	TENSION LEVER ASSEMBLY			
L1051	TJ14055	SCREW (M2.6X6)			
L1053	TJ15313	SCREW (M2.6X8)			
L1151	TJ15236	SCREW (M2.6X4)			
L1191	TJ15313	SCREW (M2.6X8)			
L1321	TJ10176	SCREW (M3X6)			
L1341	TE13298	SCREW (M2.6X6)			
L1406	TJ15238	AC HEAD SCREW			
L1450	TE12971	SCREW (M2.6X5)			
L1461	TJ14061	SCREW (M2.6X6)			
L1466	TJ14066	SCREW (M2.6X6)			
L1467	TJ15958	SCREW (M2.6X5)			
L1468	TJ15959	SCREW (M1.7X12)			
001	TS17731	DVD MAIN CBA UNIT			
<b>ACCESSORIES</b>					
X1	TE15311	REMOTE CONTROL UNIT [DV-PF2E(UK)]			
X1	TE15321	REMOTE CONTROL UNIT [DV-PF2E]			
X3	TE15231	RF CORD			

# Electrical Parts List

**Note:** Although some parts in the schematic diagrams have different names from those in the parts list, there is no problem in replacing parts.

SYMBOL-NO	P-NO	DESCRIPTION	SYMBOL-NO	P-NO	DESCRIPTION
<b>RESISTOR</b>			D1008	TJ14082	SCHOTTKY BARRIER DIODE SB340
VR501	TJ13934	CARBON P.O.T. 100K OHM B	D1009	TJ15128	RECTIFIER DIODE FR202
<b>SEMI-CONDUCTORS</b>			D1010	TC10753	RECTIFIER DIODE ERA18-04
D2	TC10112	SWITCHING DIODE 1SS133(T-77)	D1011	TC12441	RECTIFIER DIODE BA159
D013	TC10753	RECTIFIER DIODE ERA18-04	D1012	TC10112	SWITCHING DIODE 1SS133(T-77)
D015	TJ15128	RECTIFIER DIODE FR202	D1013	TC10604	ZENER DIODE MTZJT-779.1C
D052	TC10877	SCHOTTKY BARRIER DIODE SB140	D1014	TJ13896	ZENER DIODE MTZJT-775.1C
D053	TC10752	RECTIFIER DIODE 1N4005	D1015	TC12191	ZENER DIODE DZ-6.8BSBT265
D054	TJ13919	ZENER DIODE MTZJT-7710B	D1016	TJ15333	RECTIFIER DIODE FR101
D055	TC10752	RECTIFIER DIODE 1N4005	D1017	TC12654	ZENER DIODE DZ-18BSCT265
D056	TC10112	SWITCHING DIODE 1SS133(T-77)	D1018	TC10112	SWITCHING DIODE 1SS133(T-77)
D057	TC10877	SCHOTTKY BARRIER DIODE SB140	D1022	TC10112	SWITCHING DIODE 1SS133(T-77)
D101	TC12613	ZENER DIODE DZ-11BSAT265	D1024	TC10112	SWITCHING DIODE 1SS133(T-77)
D102	TC12613	ZENER DIODE DZ-11BSAT265	D1025	TC10112	SWITCHING DIODE 1SS133(T-77)
D103	TC12613	ZENER DIODE DZ-11BSAT265	D1030	TJ15128	RECTIFIER DIODE FR202
D104	TC12613	ZENER DIODE DZ-11BSAT265	D1041	TC10752	RECTIFIER DIODE 1N4005
D105	TC12613	ZENER DIODE DZ-11BSAT265	D1042	TC10752	RECTIFIER DIODE 1N4005
D106	TC12613	ZENER DIODE DZ-11BSAT265	D1043	TC10752	RECTIFIER DIODE 1N4005
D107	TC12613	ZENER DIODE DZ-11BSAT265	D1052	TC12201	ZENER DIODE DZ-13BSBT265
D108	TC12613	ZENER DIODE DZ-11BSAT265	D1060	TC10112	SWITCHING DIODE 1SS133(T-77)
D109	TC12613	ZENER DIODE DZ-11BSAT265	D1401	TC12613	ZENER DIODE DZ-11BSAT265
D110	TC12613	ZENER DIODE DZ-11BSAT265	D1402	TC12613	ZENER DIODE DZ-11BSAT265
D112	TC12613	ZENER DIODE DZ-11BSAT265	D2001	TC10112	SWITCHING DIODE 1SS133(T-77)
D113	TC12613	ZENER DIODE DZ-11BSAT265	D2003	TC10112	SWITCHING DIODE 1SS133(T-77)
D115	TC12613	ZENER DIODE DZ-11BSAT265	D2004	TC10112	SWITCHING DIODE 1SS133(T-77)
D118	TC12613	ZENER DIODE DZ-11BSAT265	D2005	TC10112	SWITCHING DIODE 1SS133(T-77)
D119	TC12613	ZENER DIODE DZ-11BSAT265	IC1	TC12622	IC MSP3417G-QG-B8
D121	TC12613	ZENER DIODE DZ-11BSAT265	IC301	TC12616	IC LA71750AM-MTB
D301	TC10112	SWITCHING DIODE 1SS133(T-77)	IC451	TC12617	IC LA72646M-A-MPB
D506	TC12491	LED(GREEN) 204-10GD/S957	IC501	TC12652	IC M37762MCA-1C4GP
D507	TC12491	LED(GREEN) 204-10GD/S957	IC502	TJ15338	IC BR24C02F-W
D508	TJ15414	LED(RED) 204HD/E	IC631	TC12653	IC LC74793JM-TRM
D510	TC10112	SWITCHING DIODE 1SS133(T-77)	IC751	TC12531	IC TC4053BF(N)
D511	TC12651	ZENER DIODE DZ-7.5BSAT265	△ IC1001	TE13224	PHOTOCOUPLER LTV-817B-F
D512	TC10112	SWITCHING DIODE 1SS133(T-77)	IC1002	TC12241	IC KIA431-AT
D555	TJ13898	LED SIR-563ST3F P	△ IC1041	TC12541	IC KIA78R33PI
D651	TJ15414	LED(RED) 204HD/E	△ IC1052	TC12231	IC PQ018EF01SZ
D652	TJ15414	LED(RED) 204HD/E	IC1053	TC12241	IC KIA431-AT
D653	TC12491	LED(GREEN) 204-10GD/S957	IC1201	TC12251	IC KIA4558P
D654	TJ15414	LED(RED) 204HD/E	IC1204	TC12261	TRANS.MODULE OC-0805T-002
D701	TC10607	ZENER DIODE MTZJT-7733D	IC1402	TC12661	IC MM1567AJBE
D751	TJ14691	ZENER DIODE MTZJT-778.2A	IC2001	TC12281	IC PT6315-S(-TP)
D1001	TC10752	RECTIFIER DIODE 1N4005	Q051	TC12581	TRANSISTOR KTA1281(Y)
D1002	TC10752	RECTIFIER DIODE 1N4005	Q052	TC12591	TRANSISTOR KRC103M
D1003	TC10752	RECTIFIER DIODE 1N4005	Q053	TJ15342	TRANSISTOR KRA104M
D1004	TC10752	RECTIFIER DIODE 1N4005	Q054	TC12591	TRANSISTOR KRC103M
D1005	TC12631	SCHOTTKY BARRIER DIODE SB350	Q055	TC10778	TRANSISTOR KTC3199(Y)
D1006	TC10112	SWITCHING DIODE 1SS133(T-77)	Q056	TE13235	TRANSISTOR KTC3203(Y)
			Q057	TJ13923	TRANSISTOR KRA103M
			Q101	TC10778	TRANSISTOR KTC3199(Y)

SYMBOL-NO	P-NO	DESCRIPTION	SYMBOL-NO	P-NO	DESCRIPTION
Q102	TC10778	TRANSISTOR KTC3199(Y)	L3	TJ15421	INDUCTOR 18UH
Q103	TC10784	TRANSISTOR KTA1266(GR)	L4	5121287	INDUCTOR 10UH
Q104	TC10784	TRANSISTOR KTA1266(GR)	L008	TJ13909	CHOKE COIL 47UH
Q105	TC10778	TRANSISTOR KTC3199(Y)	L052	TJ13909	CHOKE COIL 47UH
Q301	TC10784	TRANSISTOR KTA1266(GR)	L053	TA12561	INDUCTOR 100UH
Q302	TC10778	TRANSISTOR KTC3199(Y)	L101	TA12047	BEAD CORE
Q401	TC10778	TRANSISTOR KTC3199(Y)	L102	TA12047	BEAD CORE
Q402	TC10778	TRANSISTOR KTC3199(Y)	L251	TJ15419	INDUCTOR 5.6UH
Q403	TE13235	TRANSISTOR KTC3203(Y)	L401	TJ13909	CHOKE COIL 47UH
Q404	TC10784	TRANSISTOR KTA1266(GR)	L402	TJ13915	INDUCTOR 47UH
Q405	TJ13923	TRANSISTOR KRA103M	L451	TJ13909	CHOKE COIL 47UH
Q406	TC10778	TRANSISTOR KTC3199(Y)	L452	TJ13909	CHOKE COIL 47UH
Q451	TC12591	TRANSISTOR KRC103M	L501	TA12561	INDUCTOR 100UH
Q501	TC10778	TRANSISTOR KTC3199(Y)	L503	TJ15138	INDUCTOR 1.8UH
Q502	TC10778	TRANSISTOR KTC3199(Y)	L701	TA12556	INDUCTOR 15UH
Q503	TJ15141	TRANSISTOR PT204-6B-12	L703	TJ13909	CHOKE COIL 47UH
Q504	TJ15141	TRANSISTOR PT204-6B-12	L704	5121287	INDUCTOR 10UH
Q506	TJ15141	TRANSISTOR PT204-6B-12	L1001	TA12575	BEAD CORE
Q507	TC10778	TRANSISTOR KTC3199(Y)	L1002	TA12575	BEAD CORE
Q508	TC10778	TRANSISTOR KTC3199(Y)	△ L1003	TJ14696	LINE FILTER 50MH
Q509	TC10778	TRANSISTOR KTC3199(Y)	L1004	TA12575	BEAD CORE
Q510	TC12591	TRANSISTOR KRC103M	L1006	TJ13909	CHOKE COIL 47UH
Q511	TC10778	TRANSISTOR KTC3199(Y)	L1007	TJ13909	CHOKE COIL 47UH
Q513	TC12591	TRANSISTOR KRC103M	L1008	TJ13909	CHOKE COIL 47UH
Q514	TE13243	TRANSISTOR KTC3199(BL)	L1009	TJ13909	CHOKE COIL 47UH
Q515	TE13243	TRANSISTOR KTC3199(BL)	L1251	TA14481	INDUCTOR 0.47UH
Q752	TC12591	TRANSISTOR KRC103M	L1521	TJ13909	CHOKE COIL 47UH
Q1001	TJ15249	MOS FET FS2KM-18A	L2001	TA12561	INDUCTOR 100UH
Q1003	TC10778	TRANSISTOR KTC3199(Y)	<b>CRYSTALS</b>		
Q1008	TC10778	TRANSISTOR KTC3199(Y)	X1	TC12623	X'TAL 18.432MHZ
Q1051	TC12411	TRANSISTOR KRA110M	X301	TJ14708	X'TAL 4.433619MHZ
Q1052	TC10778	TRANSISTOR KTC3199(Y)	X501	TE15284	X'TAL 12.000MHZ
Q1053	TC12311	TRANSISTOR KRC110M-AT	X502	TJ15148	X'TAL 32.768KHZ(20PPM)
Q1054	TC12301	TRANSISTOR KTC3205(Y)	<b>MISCELLANEOUS</b>		
Q1055	TC12321	TRANSISTOR KTA1273(Y)	CN1	TE15287	ANGLE PIN HEADER, (9P)
Q1057	TJ15283	TRANSISTOR 2SC2001(K)	CN001	TE15329	CONNECTOR (14P)
Q1201	TC10778	TRANSISTOR KTC3199(Y)	CN002	TE15331	CONNECTOR (6P)
Q1202	TC10778	TRANSISTOR KTC3199(Y)	CN050	TE15327	CONNECTOR (14P)
Q1203	TC10784	TRANSISTOR KTA1266(GR)	CN051	TE15328	CONNECTOR (6P)
Q1204	TC10784	TRANSISTOR KTA1266(GR)	CN505	TE15171	CONNECTOR (10P)
Q1351	TC10778	TRANSISTOR KTC3199(Y)	CN651	TE15171	CONNECTOR (10P)
Q1501	TC12591	TRANSISTOR KRC103M	CN701	TS17736	AFV PCB ASSEMBLY
Q1502	TC12591	TRANSISTOR KRC103M	CN1001	TE15101	FMN CONNECTOR (26P)
Q2022	TC10784	TRANSISTOR KTA1266(GR)	CN1601	TE15031	FMN CONNECTOR (21P)
PS502	TJ15282	PHOTO INTERRUPTER RPI-302C70	CN2001	TE15161	FMN CONNECTOR (10P)
<b>TRANSFORMER</b>			CN2002	TE15161	FMN CONNECTOR (10P)
△ T001	TA14611	PULSE TRANS CSA-SW0120A	△ F1001	TJ14705	FUSE T1.6AL/250V
<b>COILS</b>			FH1001	TE11084	FUSE HOLDER
L1	5121287	INDUCTOR 10UH	FH1002	TE11084	FUSE HOLDER



SYMBOL-NO	P-NO	DESCRIPTION	SYMBOL-NO	P-NO	DESCRIPTION
FL2001	TE14801	V.F.D. 20U29100SAN			
J922	TA12575	BEAD CORE			
JK101	TE15322	21P RGB JACK			
JK102	TE15322	21P RGB JACK			
JK651	TE15183	RCA JACK(RE D)			
JK652	TE15182	RCA JACK(WHITE)			
JK653	TE15181	RCA JACK(YELLOW)			
JK751	TE15133	RCA JACK			
JK1202	TE15134	RCA JACK(BLACK)			
JK1401	TE14821	JACK			
JW002	TE15291	FFC CABLE			
JW003	TE15151	FFC CABLE (26P)			
JW004	TE15323	FFC CABLE (21P)			
JW005	TE15154	FFC CABLE (10P)			
JW006	TE15155	PARALLEL WIRE (10P)			
JW007	TE15324	PARALLEL WIRE (7P)			
JW008	TE15324	PARALLEL WIRE (7P)			
JW009	TE15325	PARALLEL WIRE (6P)			
RM2001	TC12331	REMOTE RECEIVER PIC-37043LU			
SW501	TE11957	TACT SWITCH			
SW502	TE11957	TACT SWITCH			
SW503	TE11957	TACT SWITCH			
SW504	TE11957	TACT SWITCH			
SW505	TE11957	TACT SWITCH			
SW506	TE15326	LEAF SWITCH			
SW507	TJ15142	ROTARY MODE SWITCH			
SW508	TE11957	TACT SWITCH			
SW651	TE11957	TACT SWITCH			
SW652	TE11957	TACT SWITCH			
SW653	TE11957	TACT SWITCH			
SW654	TE11957	TACT SWITCH			
SW2011	TE11957	TACT SWITCH			
SW2012	TE11957	TACT SWITCH			
SW2014	TE11957	TACT SWITCH			
SW2016	TE11957	TACT SWITCH			
SW2017	TE11957	TACT SWITCH			
TU701	TE15283	TUNER UNIT TMDG2-632A [DV-PF2E(UK)]			
TU701	TE15332	TUNER UNIT TMDG2-631A [DV-PF2E]			

## SCHEMATIC DIAGRAMS / CBA'S AND TEST POINTS

### Standard Notes

#### WARNING

Many electrical and mechanical parts in this chassis have special characteristics. These characteristics often pass unnoticed and the protection afforded by them cannot necessarily be obtained by using replacement components rated for higher voltage, wattage, etc. Replacement parts that have these special safety characteristics are identified in this manual and its supplements; electrical components having such features are identified by the mark "  $\triangle$  " in the schematic diagram and the parts list. Before replacing any of these components, read the parts list in this manual carefully. The use of substitute replacement parts that do not have the same safety characteristics as specified in the parts list may create shock, fire, or other hazards.

#### Capacitor Temperature Markings

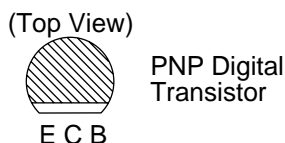
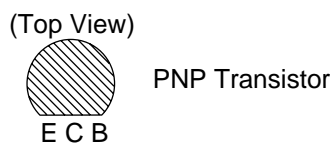
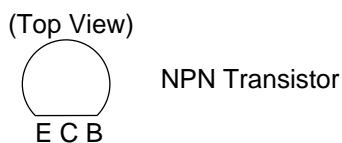
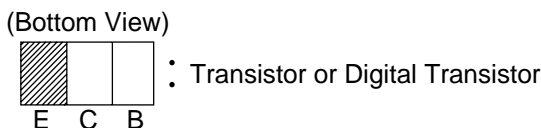
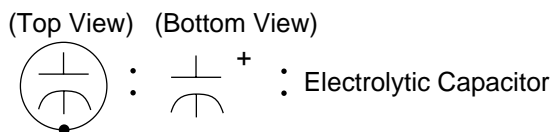
Mark	Capacity change rate	Standard temperature	Temperature range
(B)	$\pm 10\%$	20°C	-25~+85°C
(F)	+30 - 80%	20°C	-25~+85°C
(SR)	$\pm 15\%$	20°C	-25~+85°C
(Z)	+30 - 80%	20°C	-10~+70°C

### Notes:

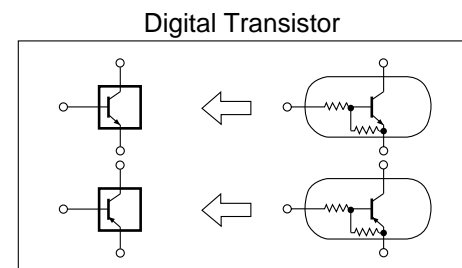
1. Do not use the part number shown on these drawings for ordering. The correct part number is shown in the parts list, and may be slightly different or amended since these drawings were prepared.
2. All resistance values are indicated in ohms ( $K=10^3$ ,  $M=10^6$ ).
3. Resistor wattages are 1/4W or 1/6W unless otherwise specified.
4. All capacitance values are indicated in  $\mu F$  ( $P=10^{-6} \mu F$ ).
5. All voltages are DC voltages unless otherwise specified.
6. Electrical parts such as capacitors, connectors, diodes, IC's, transistors, resistors, switches, and fuses are identified by four digits. The first two digits are not shown for each component. In each block of the diagram, there is a note such as shown below to indicate these abbreviated two digits.

Capacitors and transistors are represented by the following symbols.

#### CBA Symbols



#### Schematic Diagram Symbols



**LIST OF CAUTION, NOTES, AND SYMBOLS USED IN THE SCHEMATIC DIAGRAMS ON THE FOLLOWING PAGES:**

**1. CAUTION:**

FOR CONTINUED PROTECTION AGAINST FIRE HAZARD, REPLACE ONLY WITH THE SAME TYPE FUSE.

**2. CAUTION:**

Fixed Voltage (or Auto voltage selectable) power supply circuit is used in this unit.

If Main Fuse (F001) is blown, first check to see that all components in the power supply circuit are not defective before you connect the AC plug to the AC power supply. Otherwise it may cause some components in the power supply circuit to fail.

**3. Note:**

(1) Do not use the part number shown on the drawings for ordering. The correct part number is shown in the parts list, and may be slightly different or amended since the drawings were prepared.

(2) To maintain original function and reliability of repaired units, use only original replacement parts which are listed with their part numbers in the parts list section of the service manual.

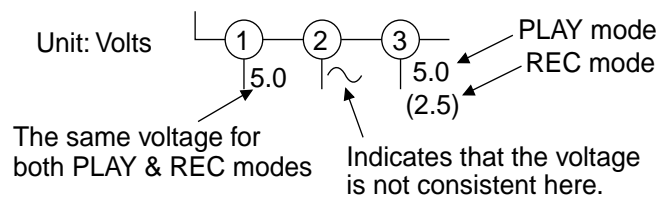
**4. Wire Connectors**

(1) Prefix symbol "CN" means "connector" (can disconnect and reconnect).

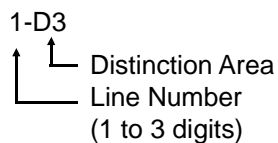
(2) Prefix symbol "CL" means "wire-solder holes of the PCB" (wire is soldered directly).

**5. Mode: SP/REC**

6. Voltage indications for PLAY and REC modes on the schematics are as shown below:

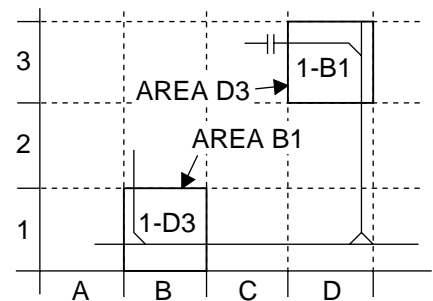


**7. How to read converged lines**



Examples:

1. "1-D3" means that line number "1" goes to area "D3".
2. "1-B1" means that line number "1" goes to area "B1".



**8. Test Point Information**

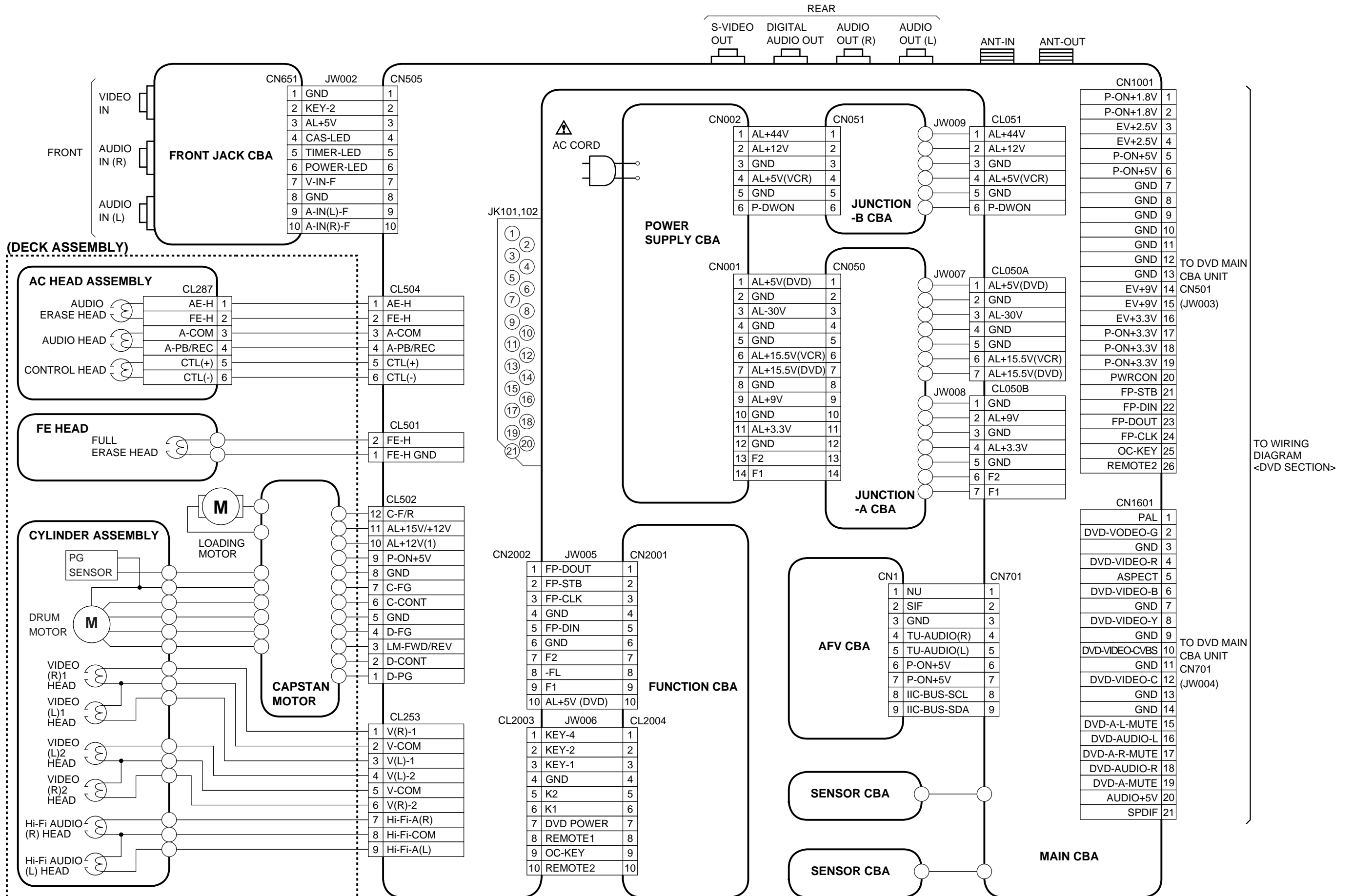
⊙ : Indicates a test point with a jumper wire across a hole in the PCB.

□→ : Used to indicate a test point with a component lead on foil side.

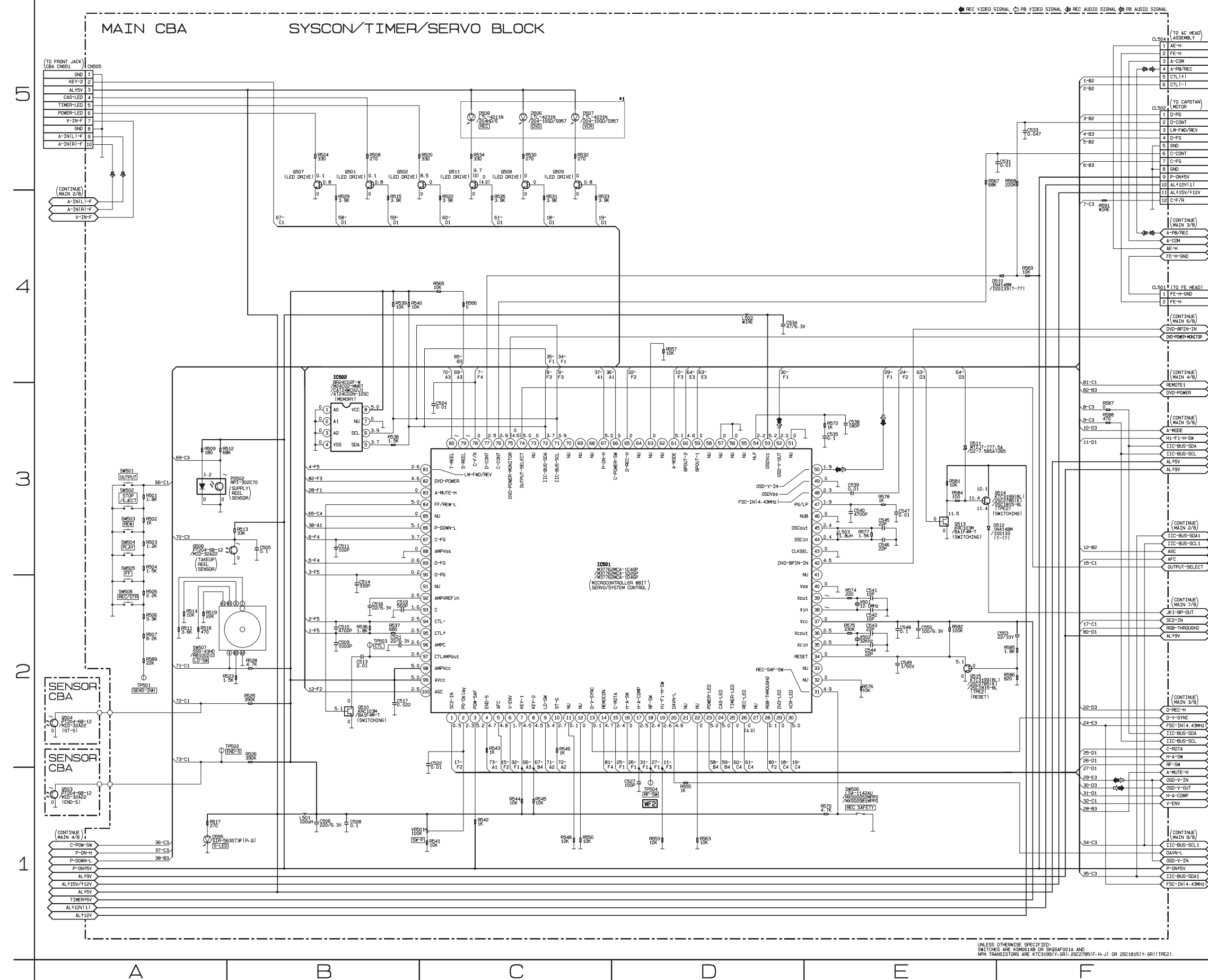
⊘ : Used to indicate a test point with no test pin.

● : Used to indicate a test point with a test pin.

# VCR SECTION Wiring Diagram

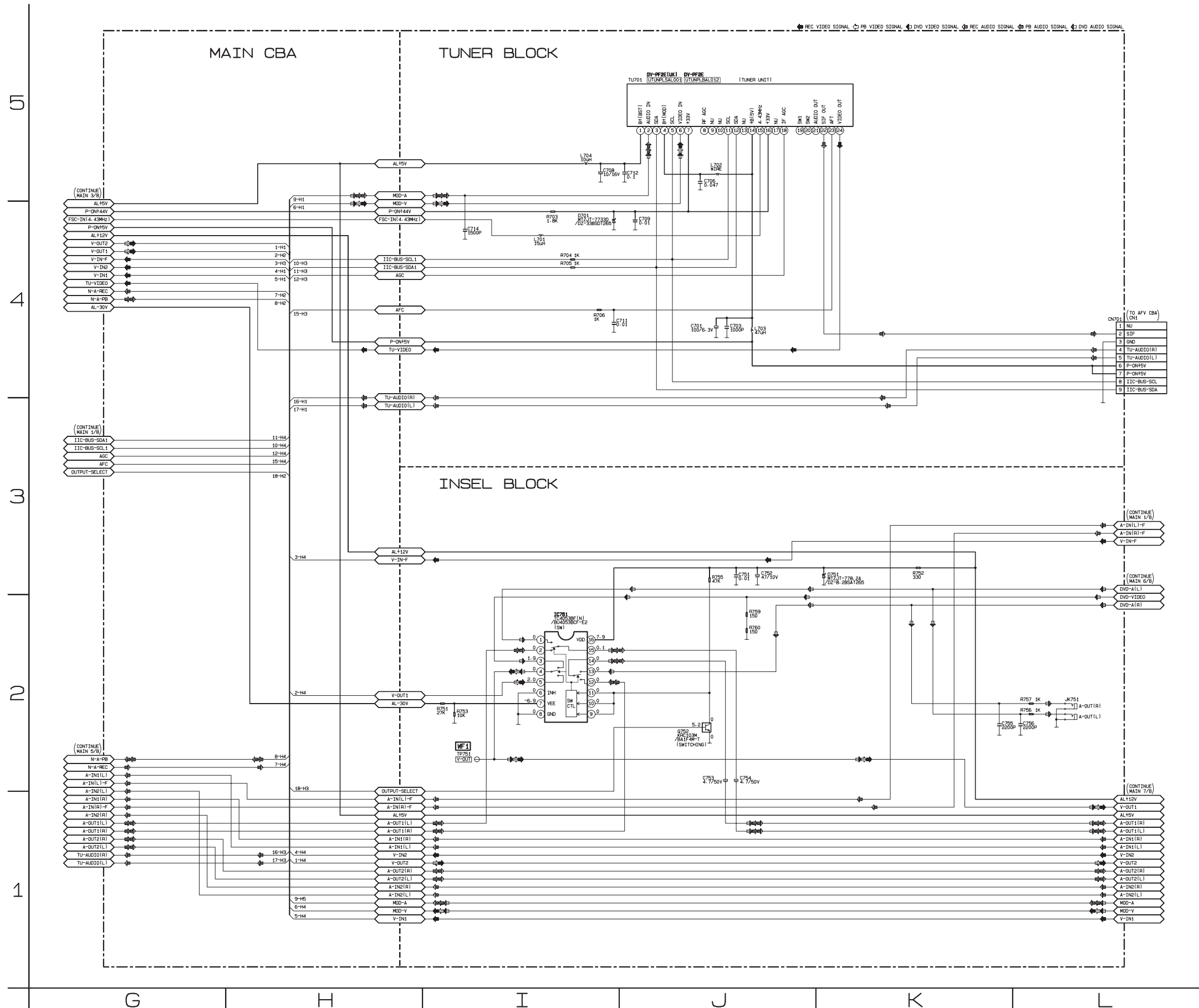


# Main 1/8 Schematic Diagram

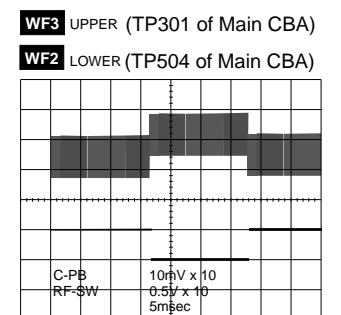
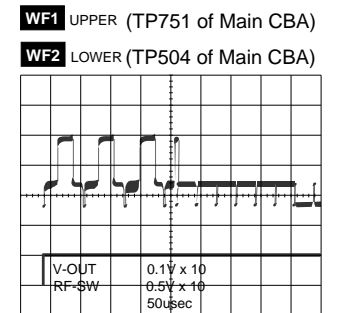
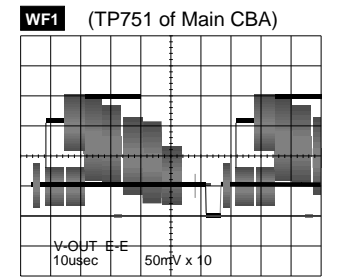


UNLESS OTHERWISE SPECIFIED:  
 SWITCHES ARE K506148 OR SK05AF014 AND  
 NPN TRANSISTORS ARE KTC1591(Y,GR), 2SC2795(F,H,J) OR 2SC1815(Y,GR) (1P2).

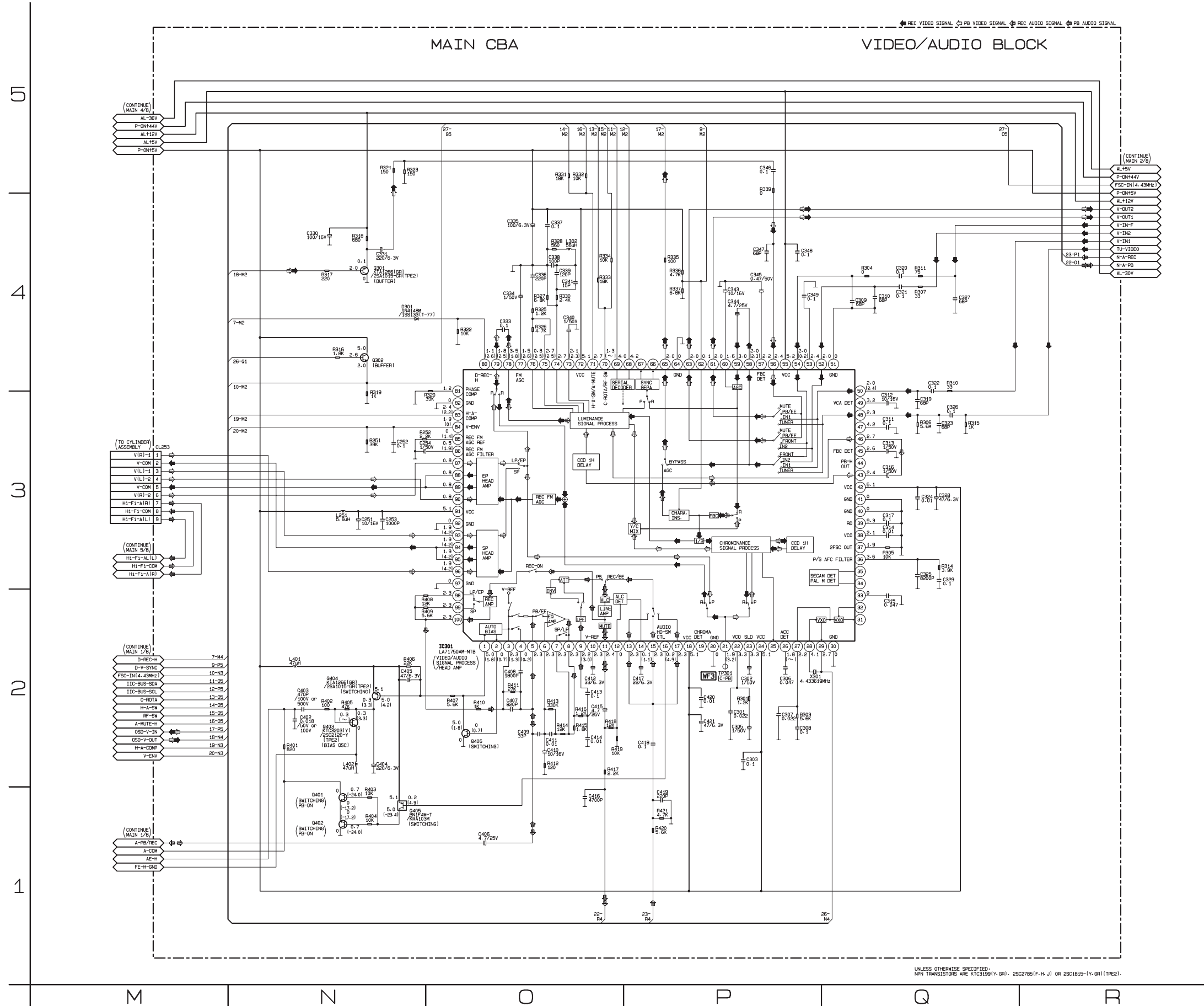
# Main 2/8 Schematic Diagram



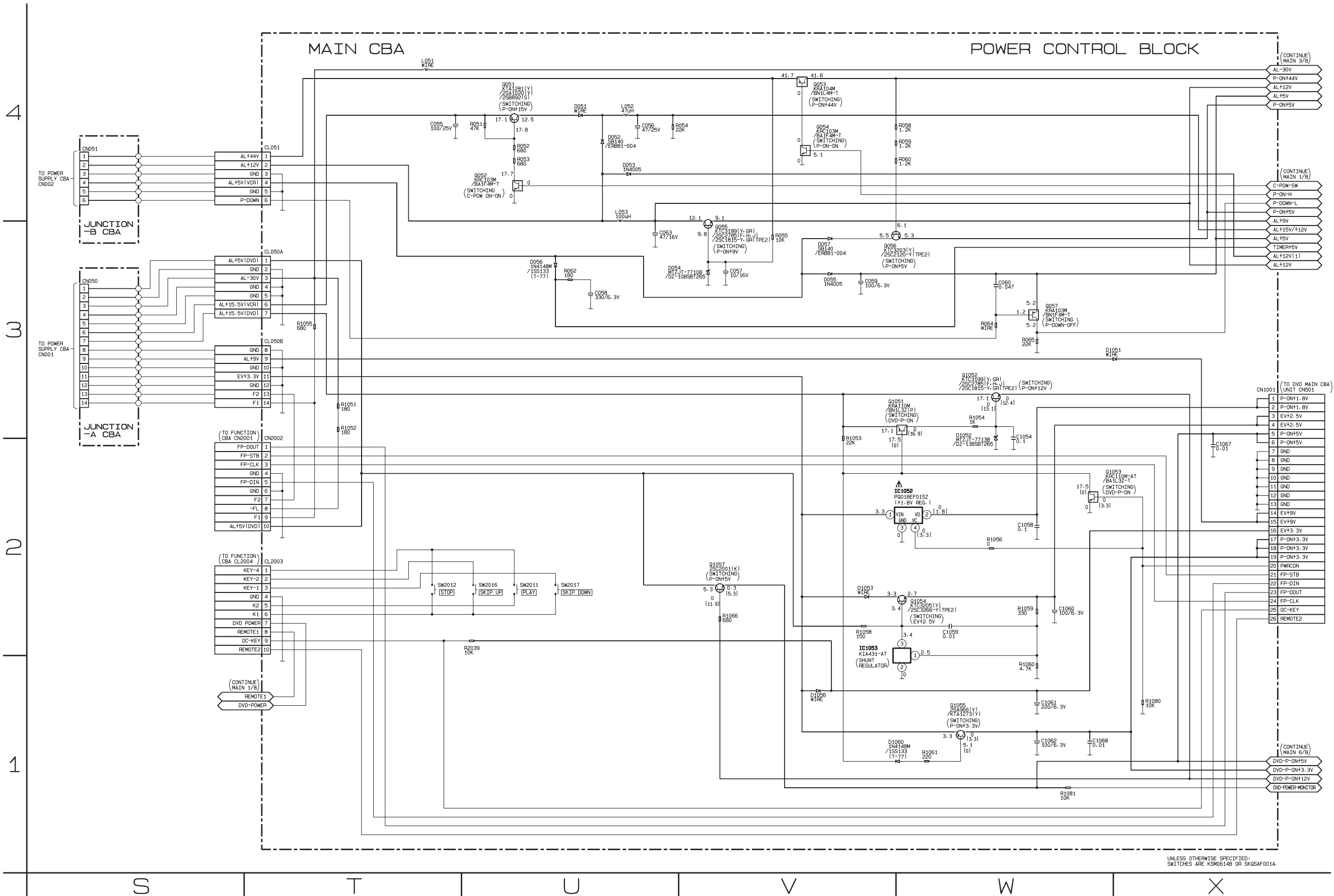
## Waveforms



# Main 3/8 Schematic Diagram



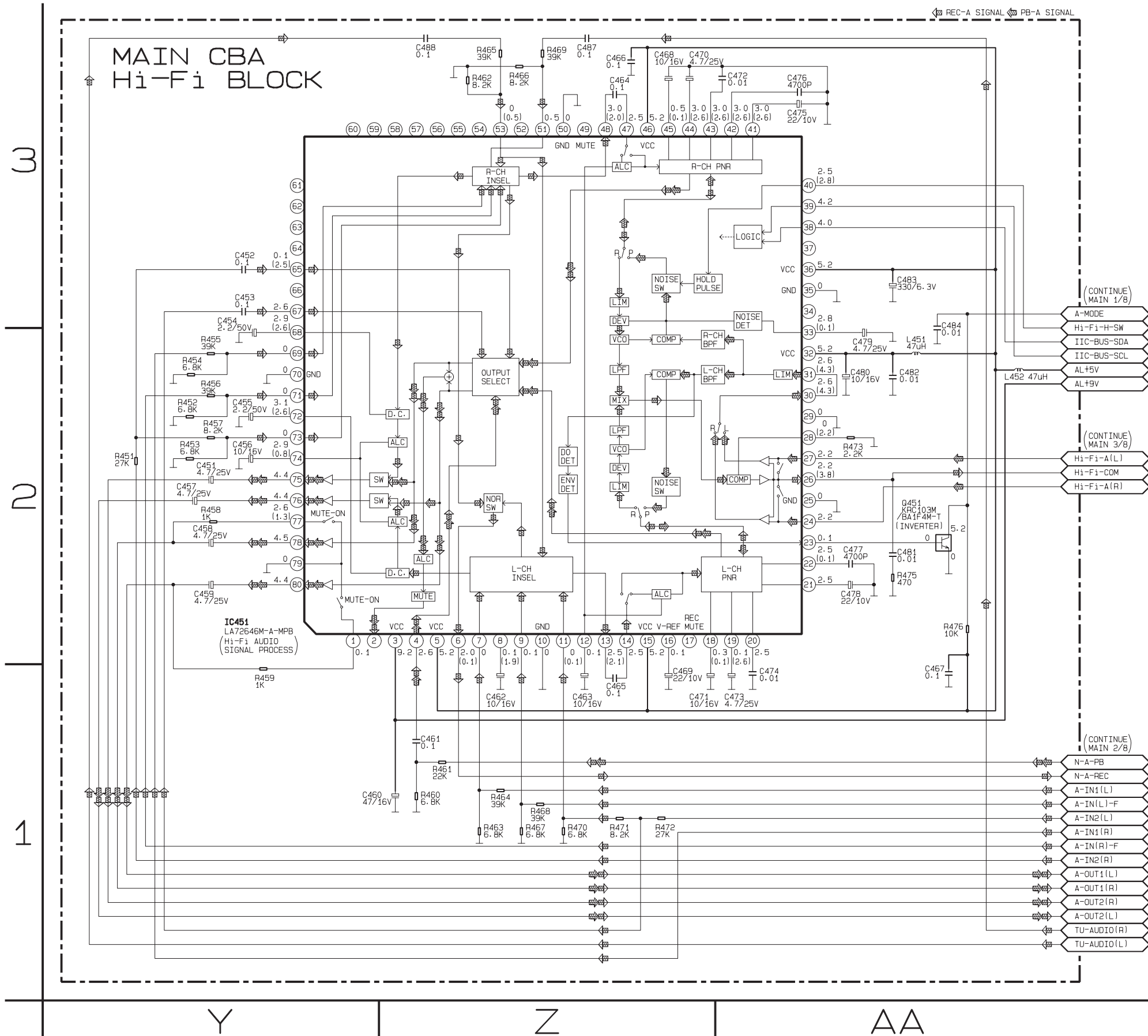
# Main 4/8 Schematic Diagram



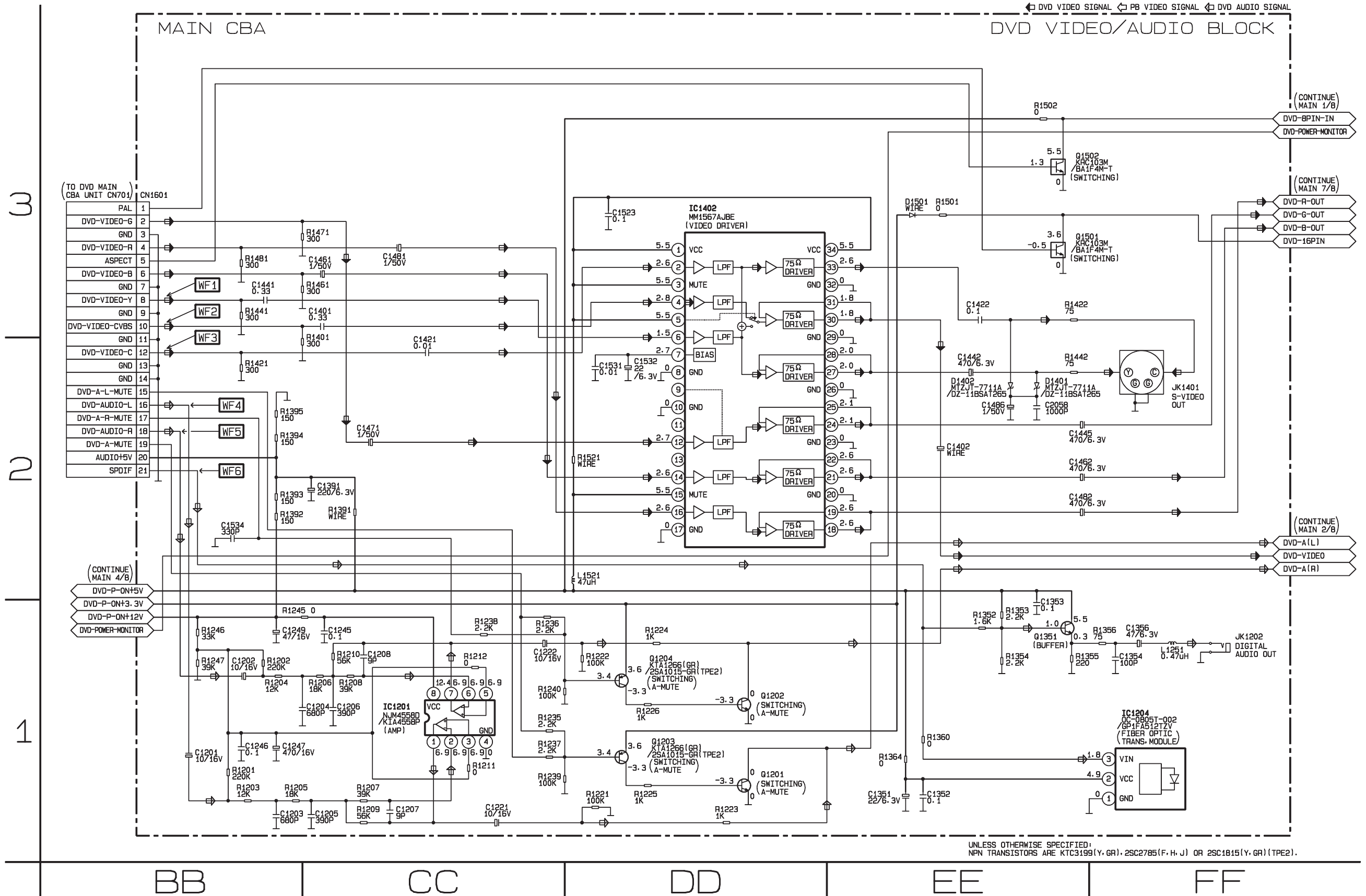
UNLESS OTHERWISE SPECIFIED:  
SWITCHES ARE K5M0614B OR SK05AF001A.



# Main 5/8 Schematic Diagram

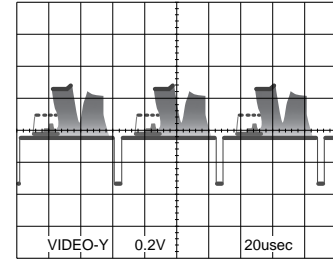


# Main 6/8 Schematic Diagram

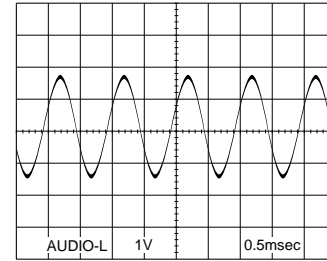


# Waveforms

**WF1** Pin 8 of CN1601

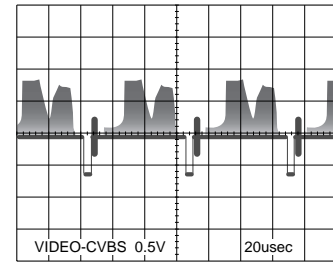


**WF4** Pin 16 of CN1601

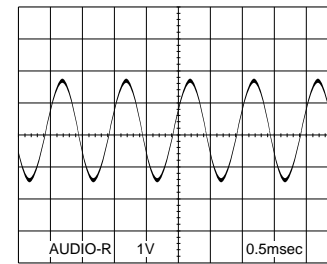


**NOTE:**  
Input  
CD: 1kHz PLAY  
(WF4~WF6)  
DVD: POWER ON (STOP) MODE  
(WF1~WF3)

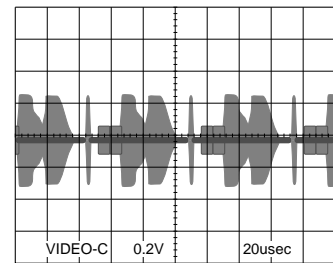
**WF2** Pin 10 of CN1601



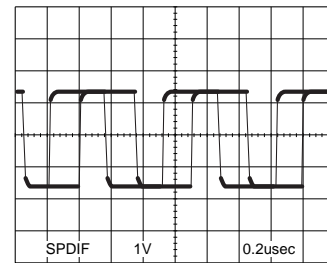
**WF5** Pin 18 of CN1601



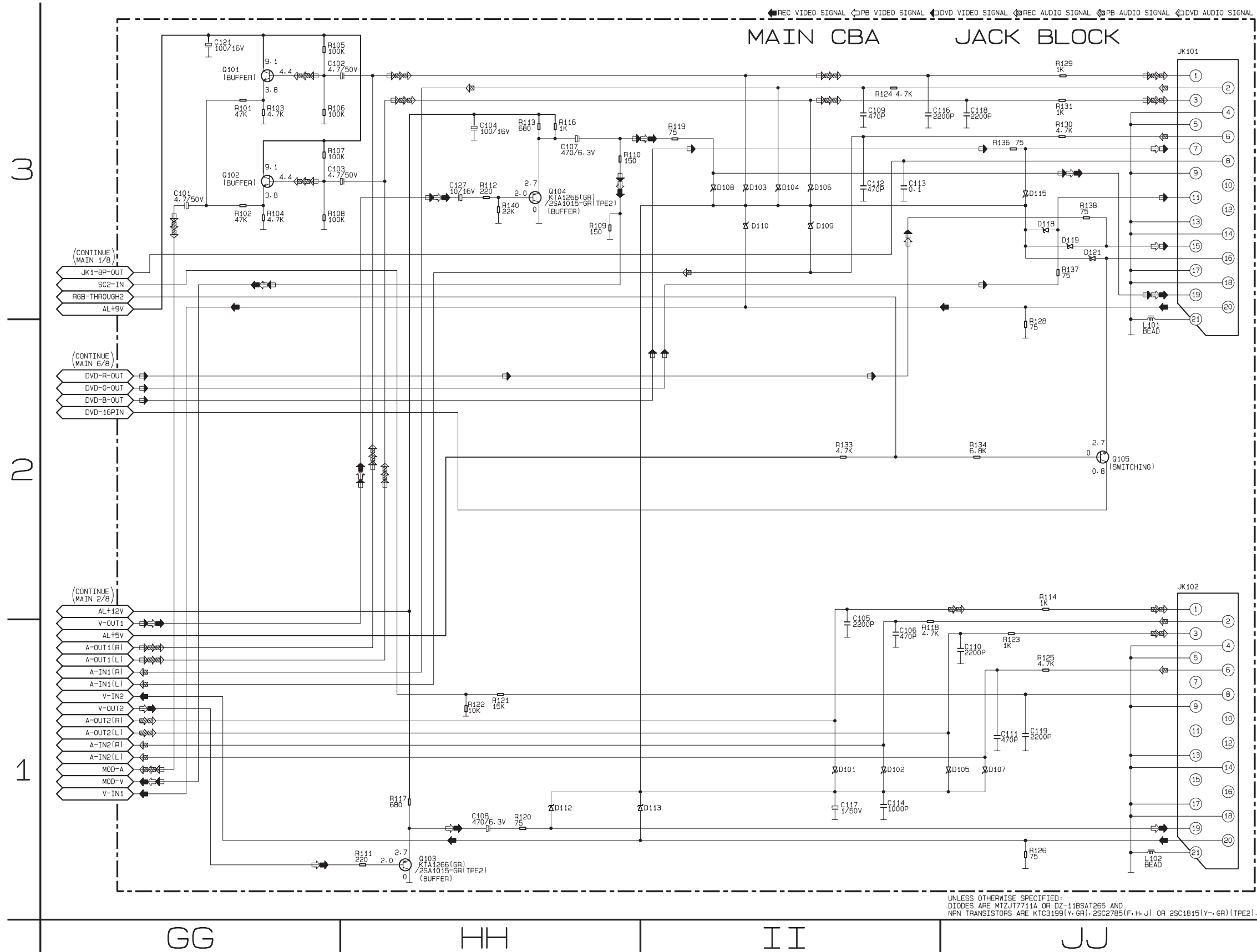
**WF3** Pin 12 of CN1601



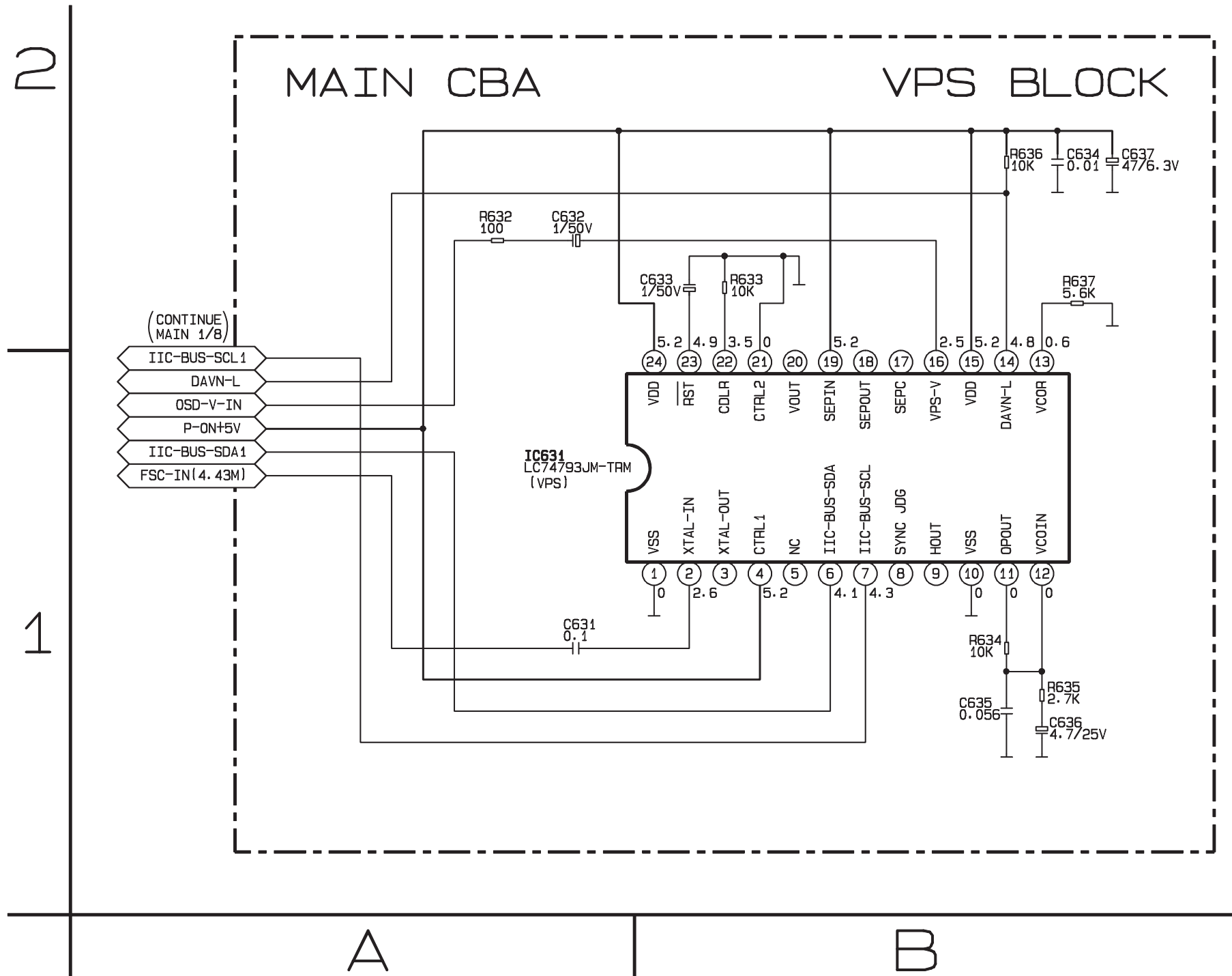
**WF6** Pin 21 of CN1601



# Main 7/8 Schematic Diagram



# Main 8/8 Schematic Diagram

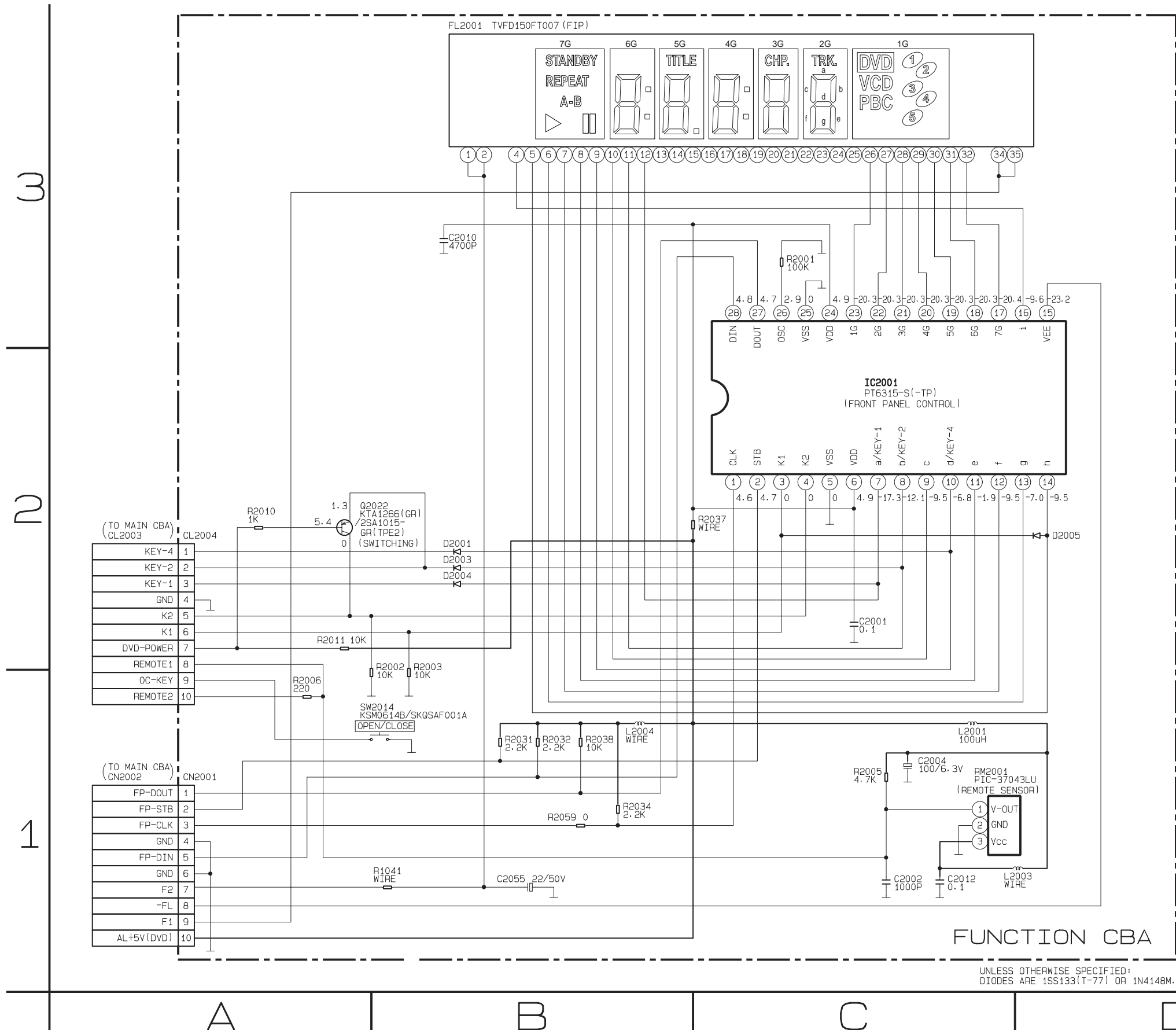




# Function Schematic Diagram

FL2001 MATRIX CHART

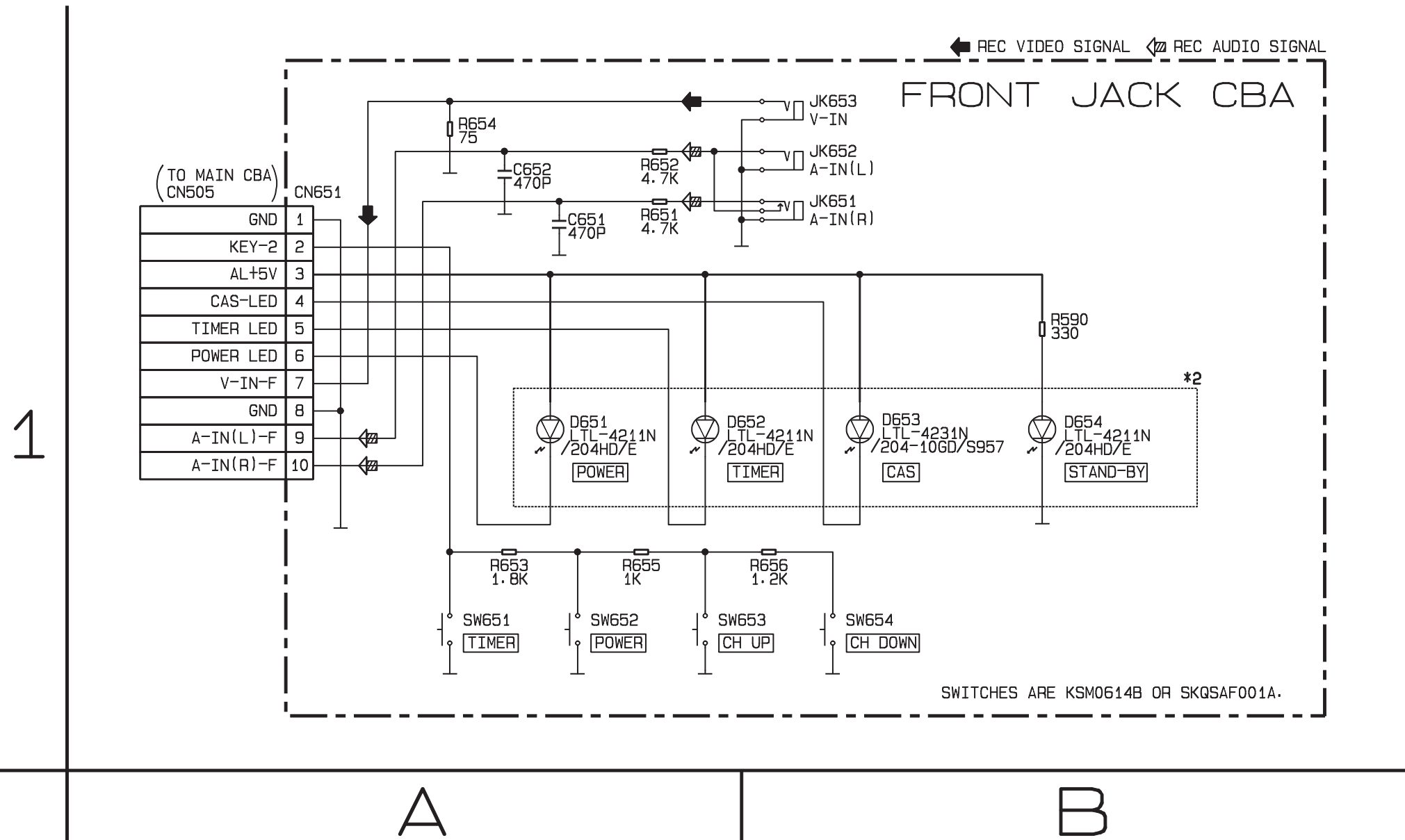
	7G	6G	5G	4G	3G	2G	1G
a	STANDBY	a	a	a	a	a	①
b	REPEAT	b	b	b	b	b	②
c	A	c	c	c	c	c	③
d	-B	d	d	d	d	d	④
e	▶	e	e	e	e	e	⑤
f	⏸	f	f	f	f	f	DVD
g	—	g	g	g	g	g	PBC
h	—	□	TITLE	□	CHP.	TRK.	CD
i	—	—	□	—	—	—	V



UNLESS OTHERWISE SPECIFIED:  
DIODES ARE 1SS133(T-77) OR 1N4148M.

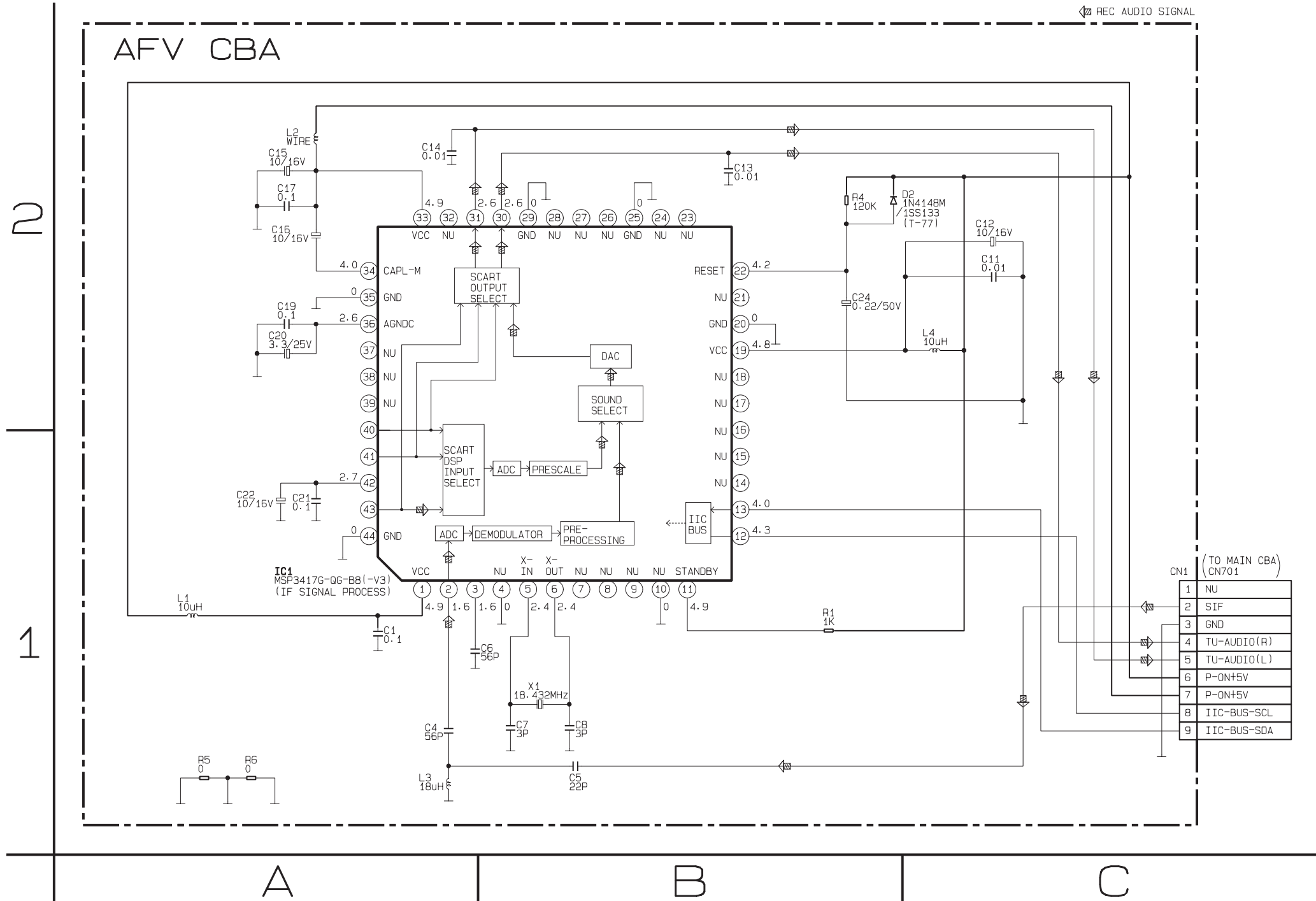
# Front Jack Schematic Diagram

**\* 2 Note:**  
 When it is necessary to replace one or more of the following Diodes, all four should be replaced: D651, D652, D653, D654.



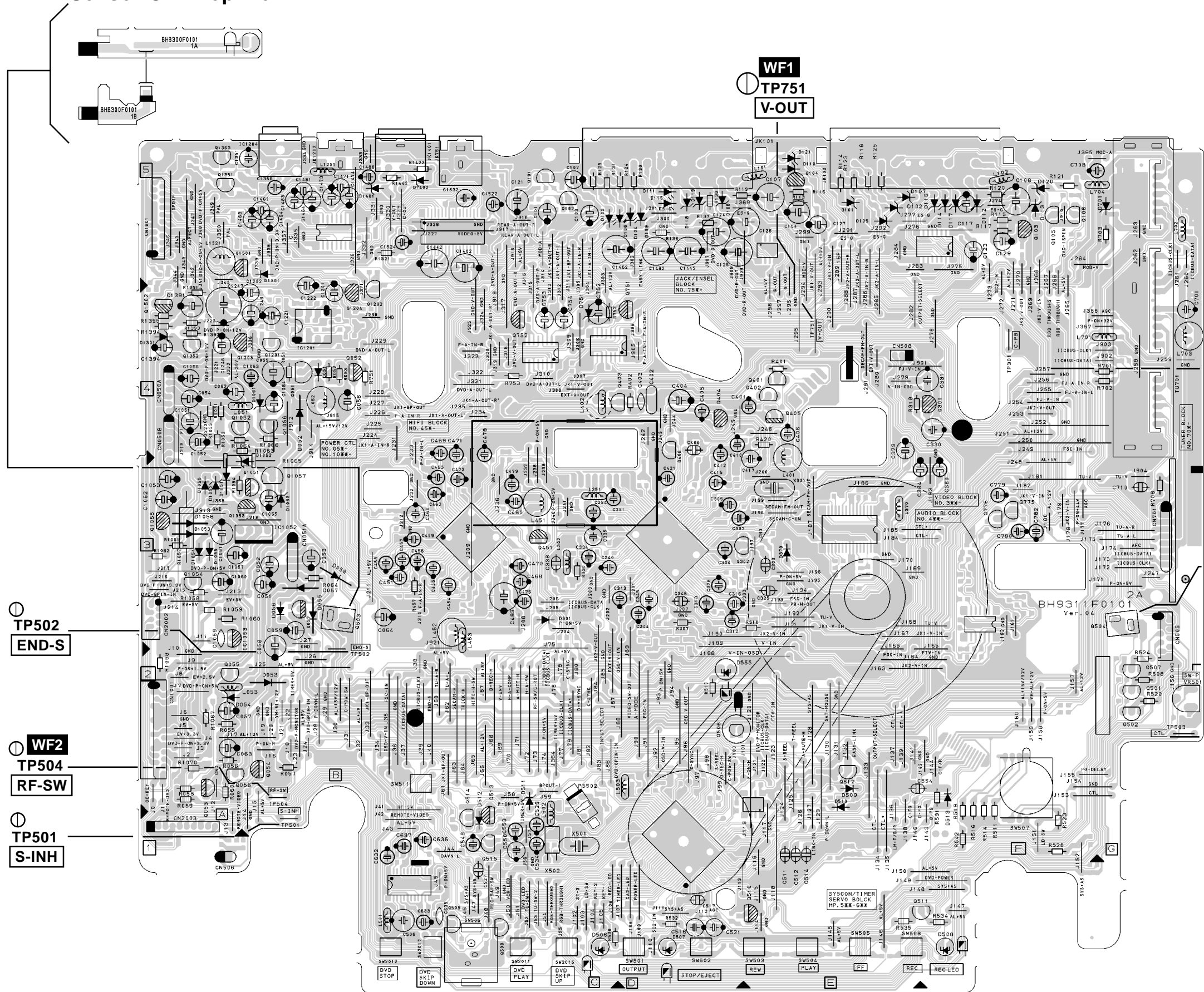


# AFV Schematic Diagram

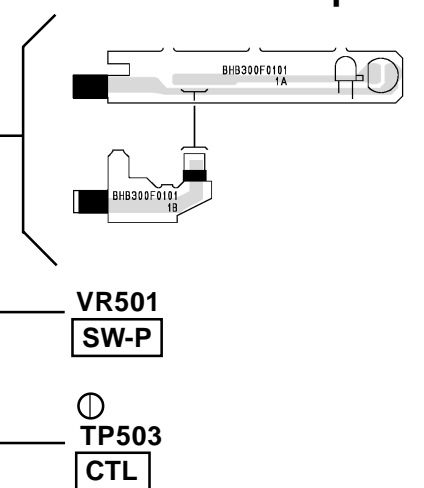


# Main CBA Top View

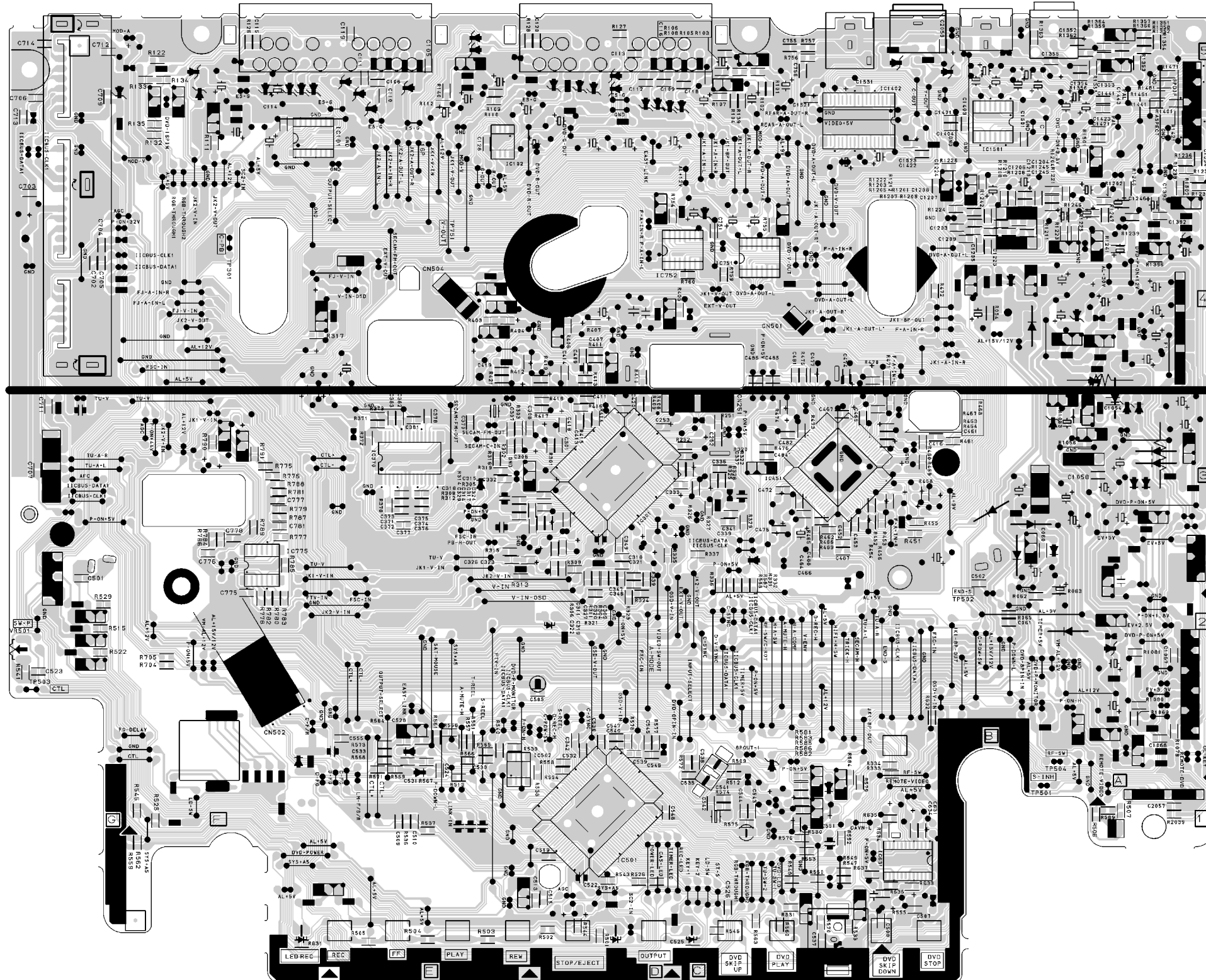
## Sensor CBA Top View



## Sensor CBA Top View



# Main CBA Bottom View



# Power Supply CBA Top View

### CAUTION!

Fixed voltage ( or Auto voltage selectable ) power supply circuit is used in this unit.  
 If Main Fuse (F001) is blown, check to see that all components in the power supply circuit are not defective before you connect the AC plug to the AC power supply.  
 Otherwise it may cause some components in the power supply circuit to fail.

### NOTE:

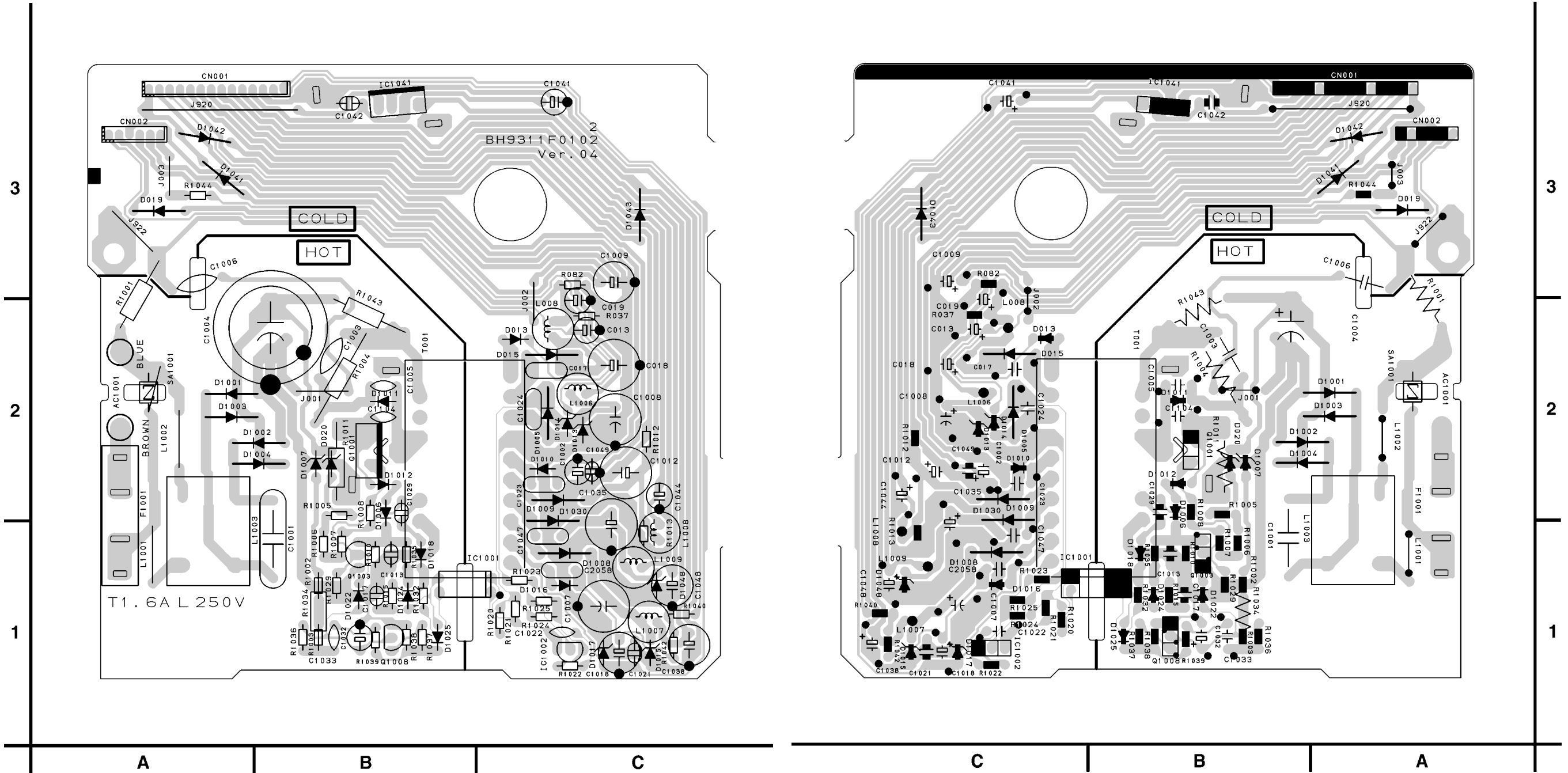
The voltage for parts in hot circuit is measured using hot GND as a common terminal.

# Power Supply CBA Bottom View

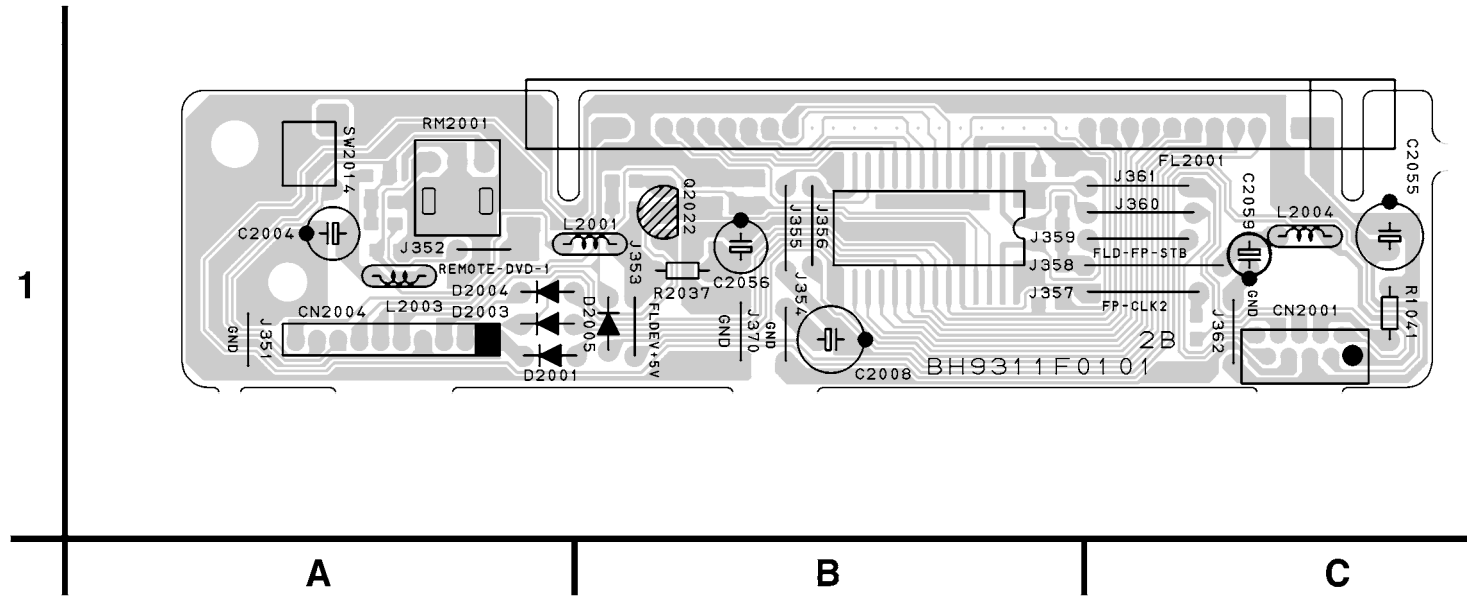
**BECAUSE A HOT CHASSIS GROUND IS PRESENT IN THE POWER SUPPLY CIRCUIT , AN ISOLATION TRANSFORMER MUST BE USED. ALSO , IN ORDER TO HAVE THE ABILITY TO INCREASE THE INPUT SLOWLY , WHEN TROUBLESHOOTING THIS TYPE POWER SUPPLY CIRCUIT , A VARIABLE ISOLATION TRANSFORMER IS REQUIRED.**

### CAUTION

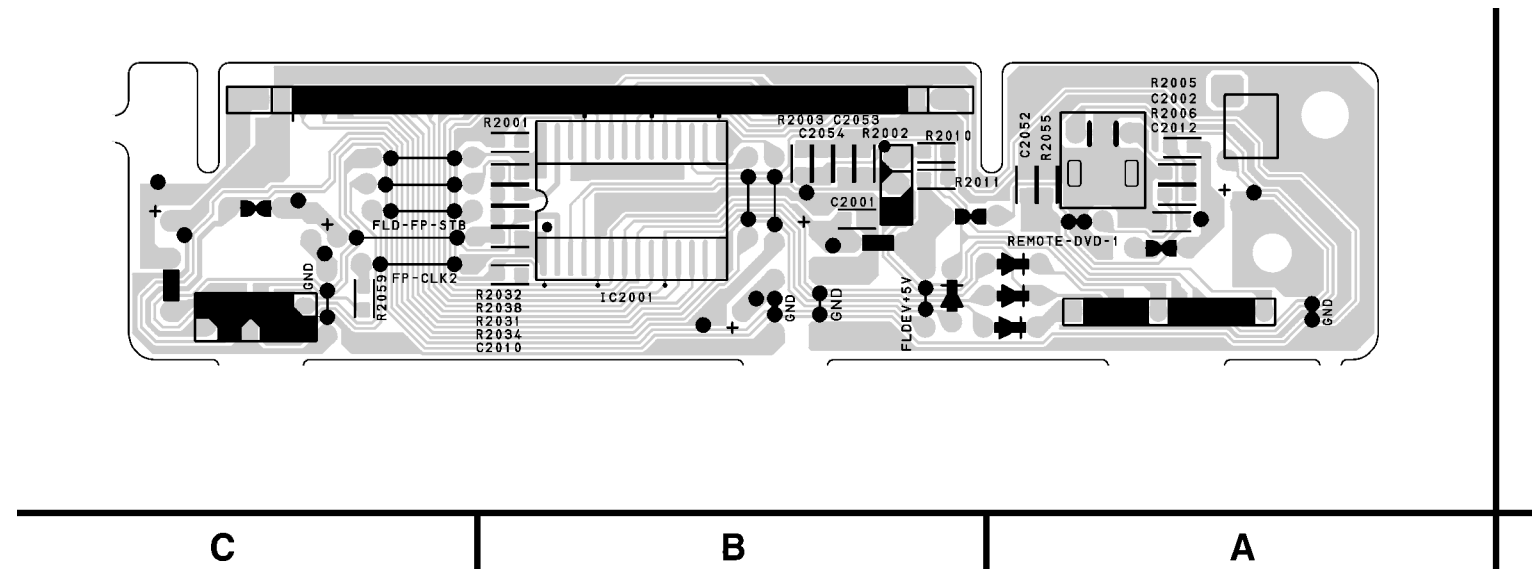
FOR CONTINUED PROTECTION AGAINST FIRE HAZARD, REPLACE ONLY WITH THE SAME TYPE FUSE.



### Function CBA Top View

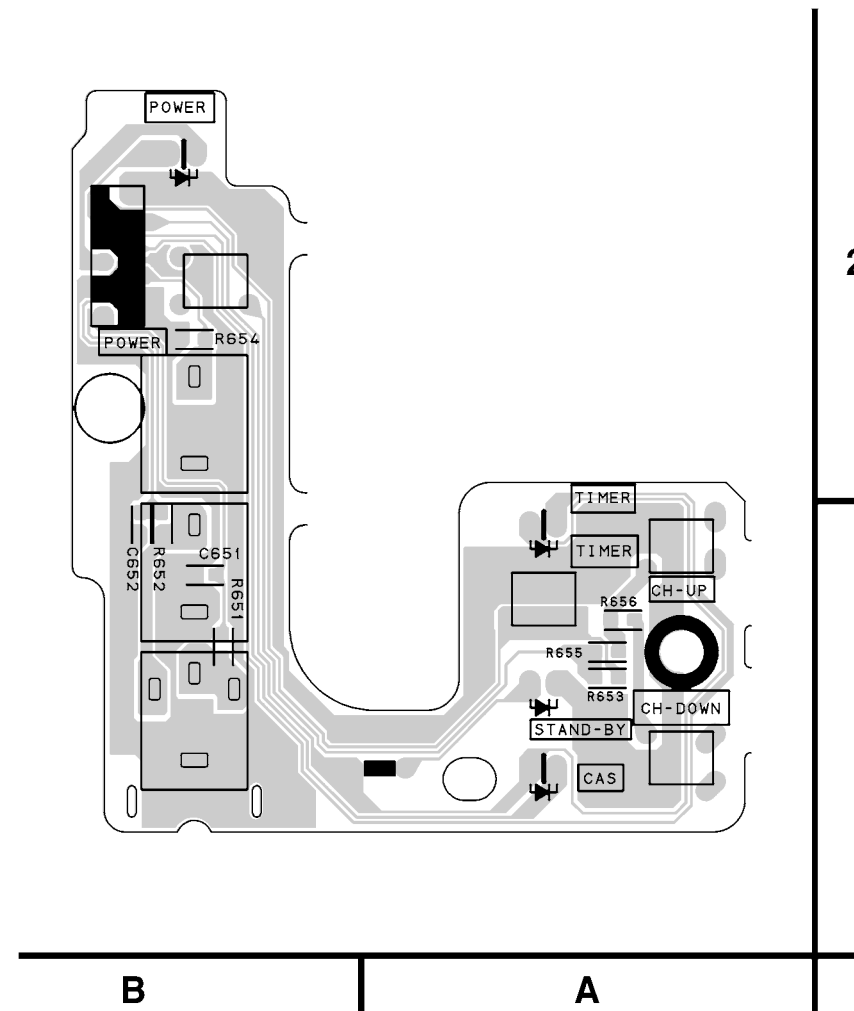
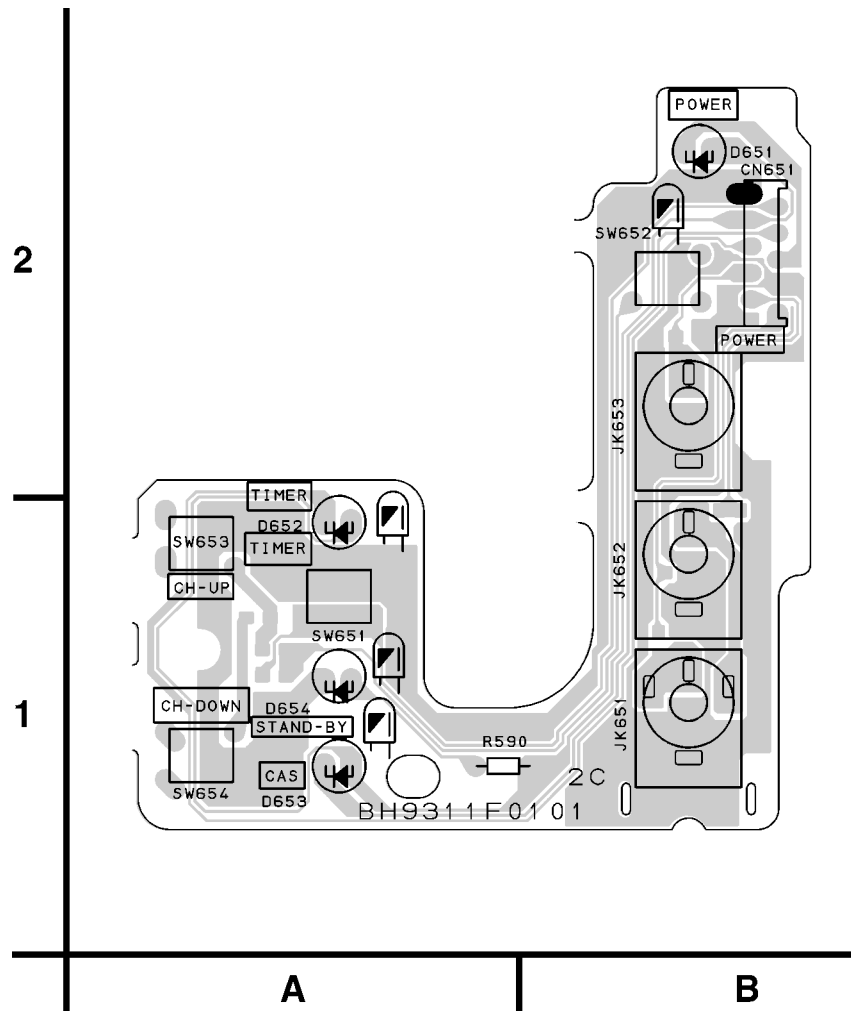


### Function CBA Bottom View

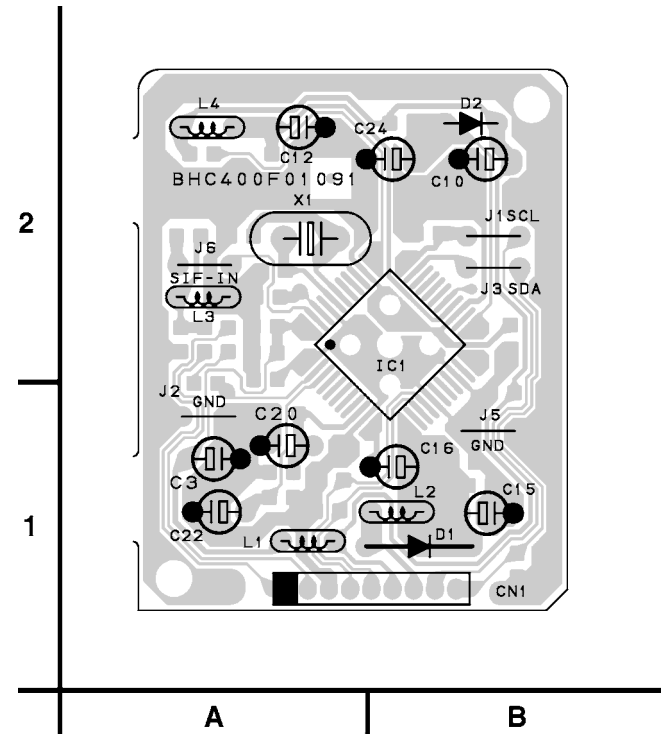


Front Jack CBA Top View

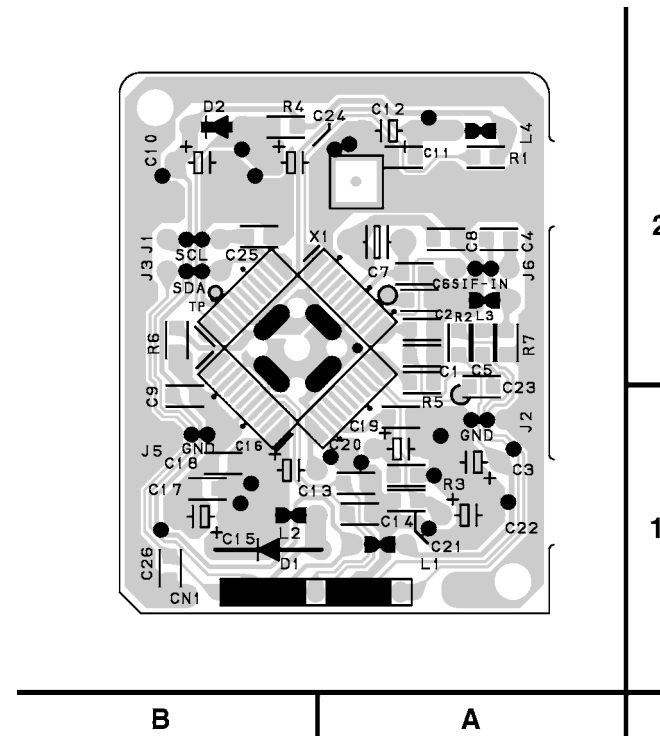
Front Jack CBA Bottom View



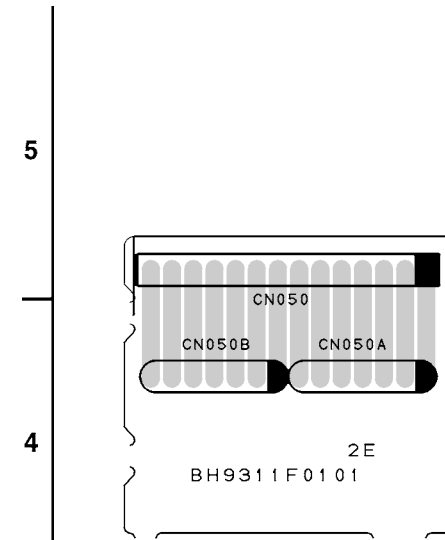
AFV CBA Top View



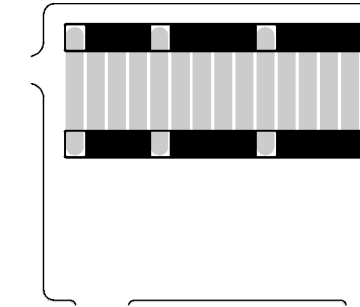
AFV CBA Bottom View



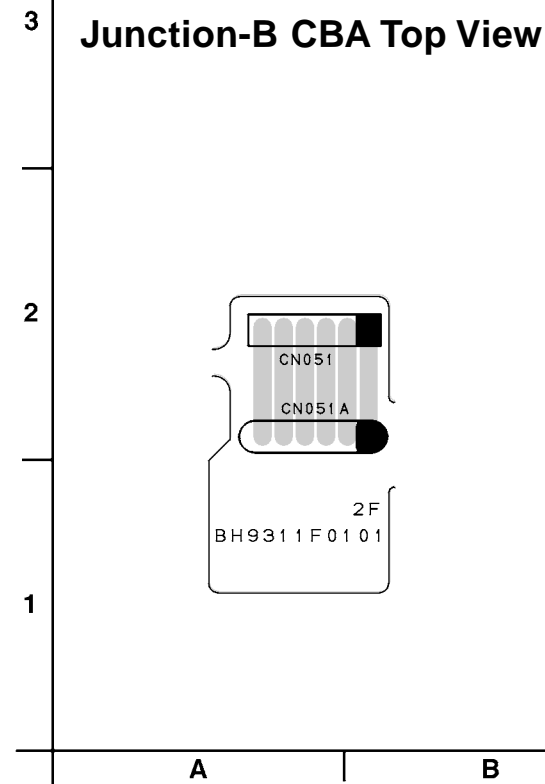
Junction-A CBA Top View



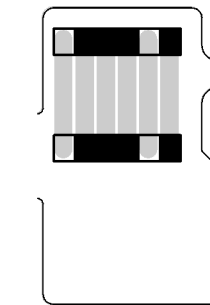
Junction-A CBA Bottom View



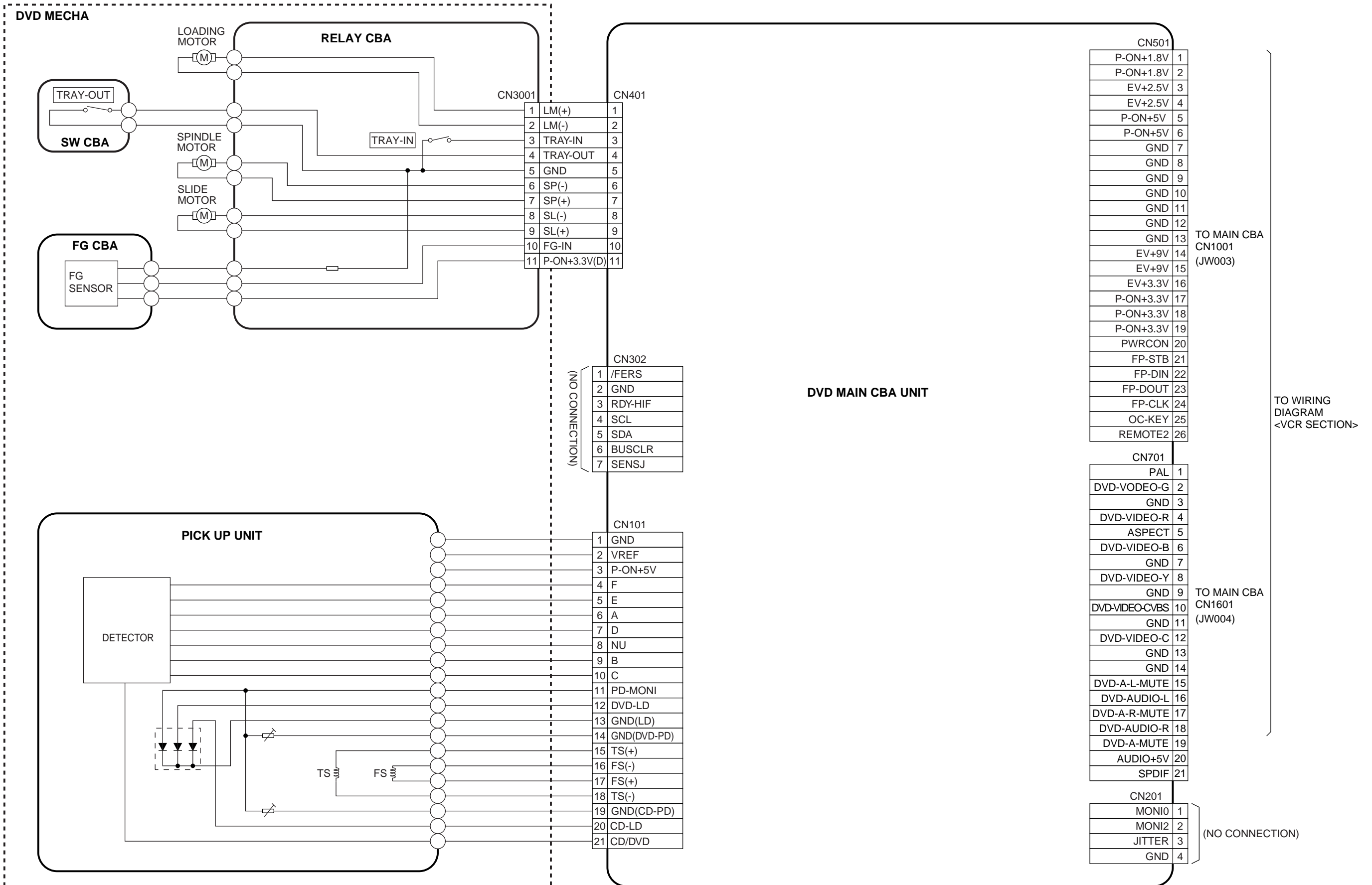
Junction-B CBA Top View



Junction-B CBA Bottom View



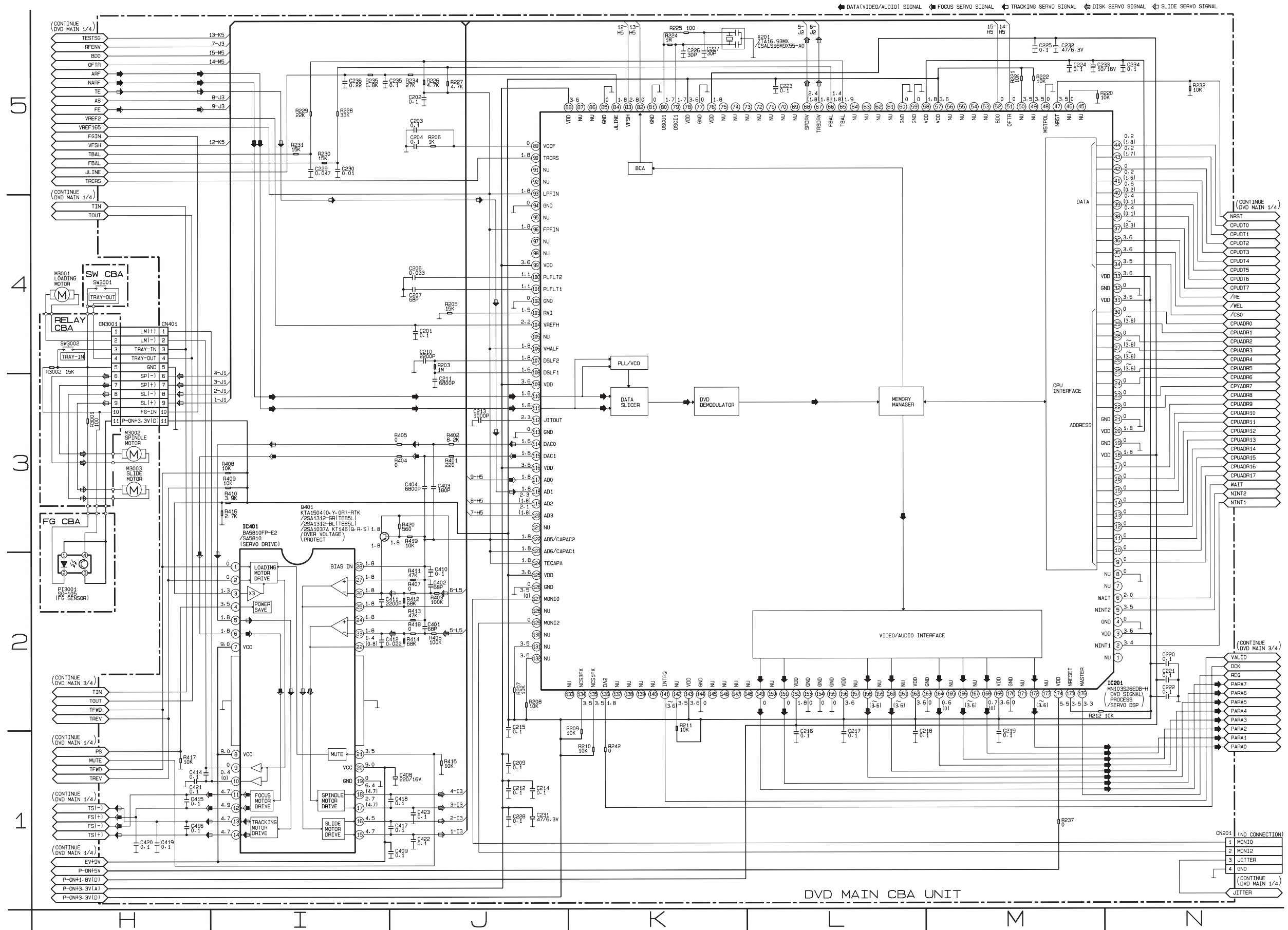
# DVD SECTION Wiring Diagram



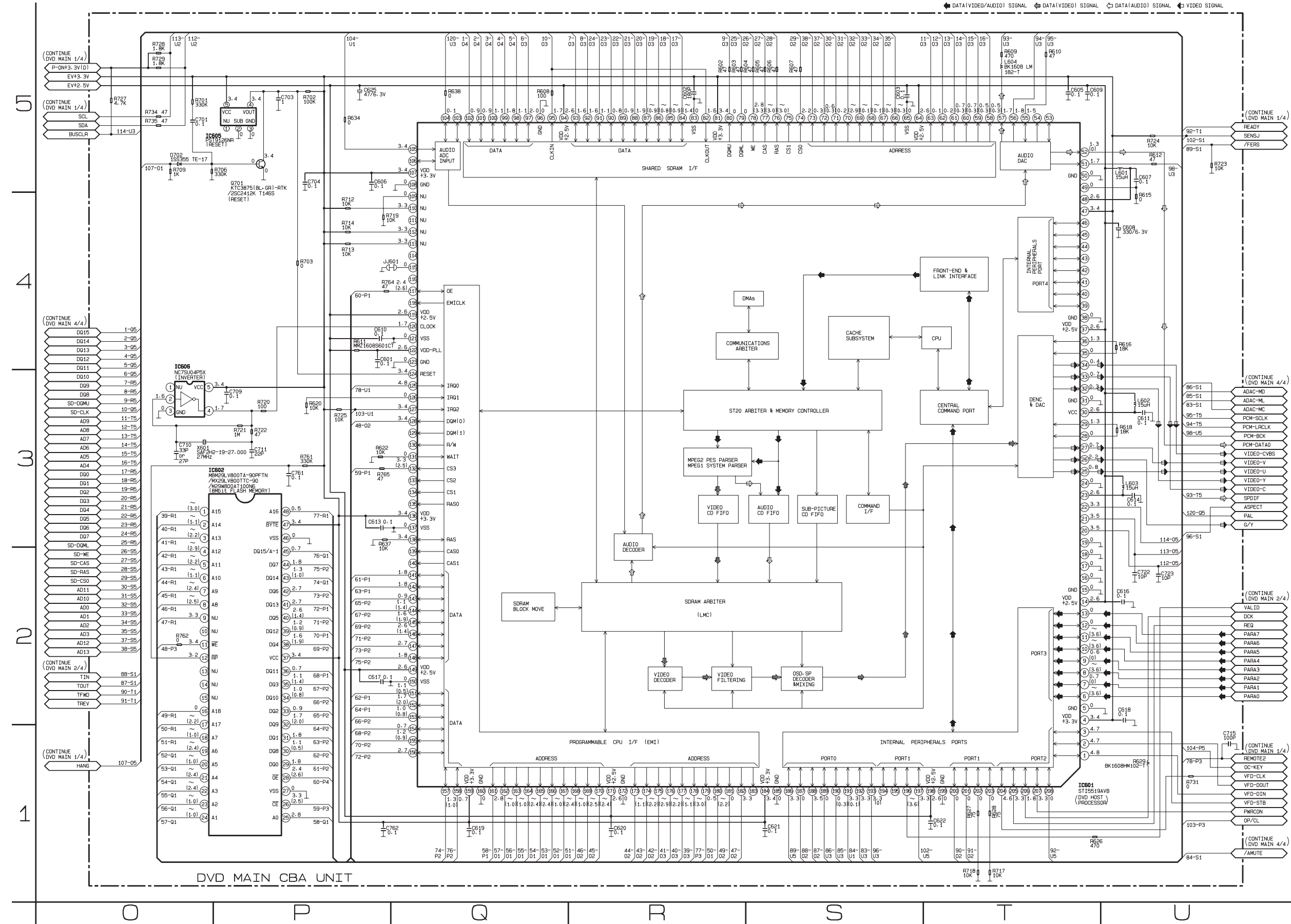




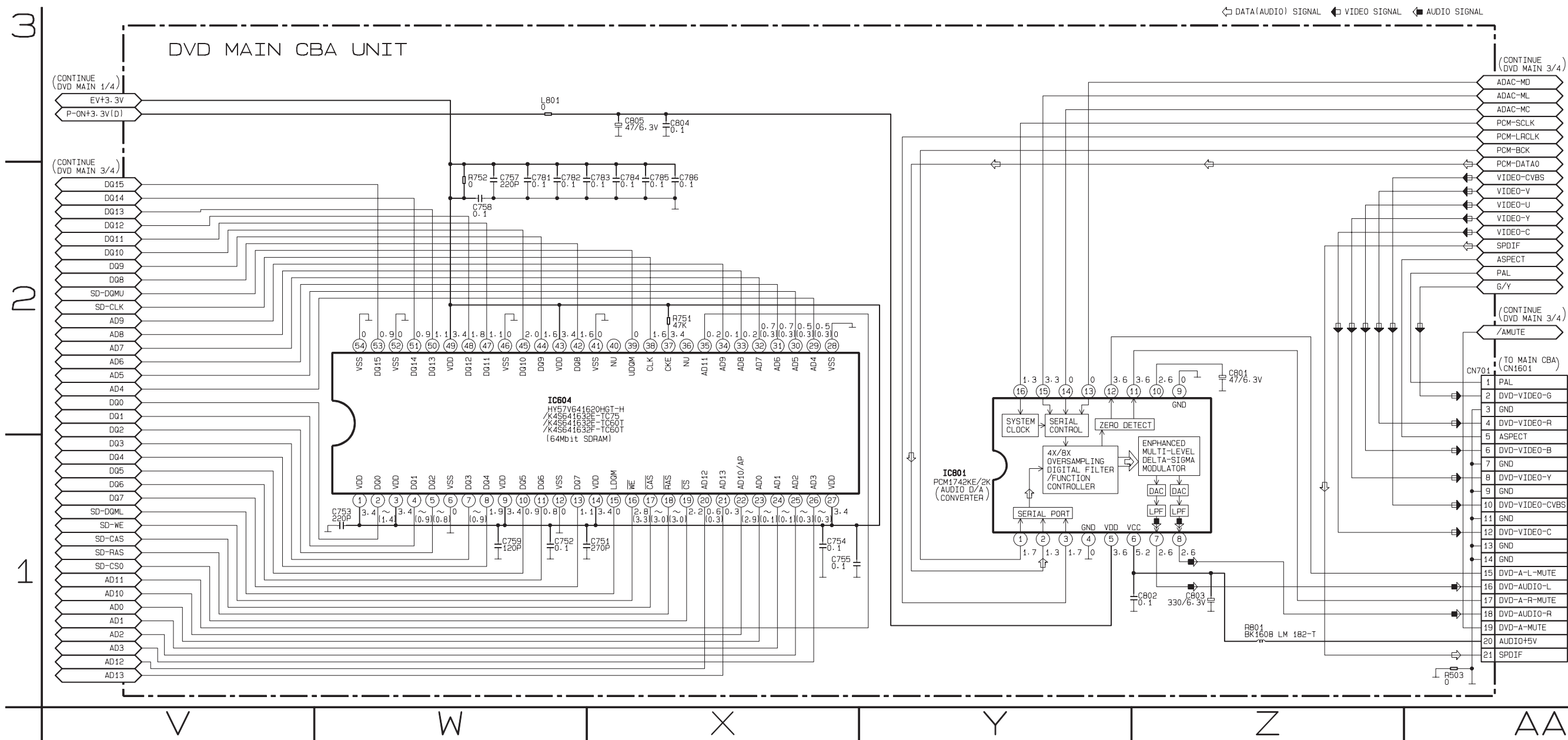
# DVD Main 2/4 Schematic Diagram



# DVD Main 3/4 Schematic Diagram



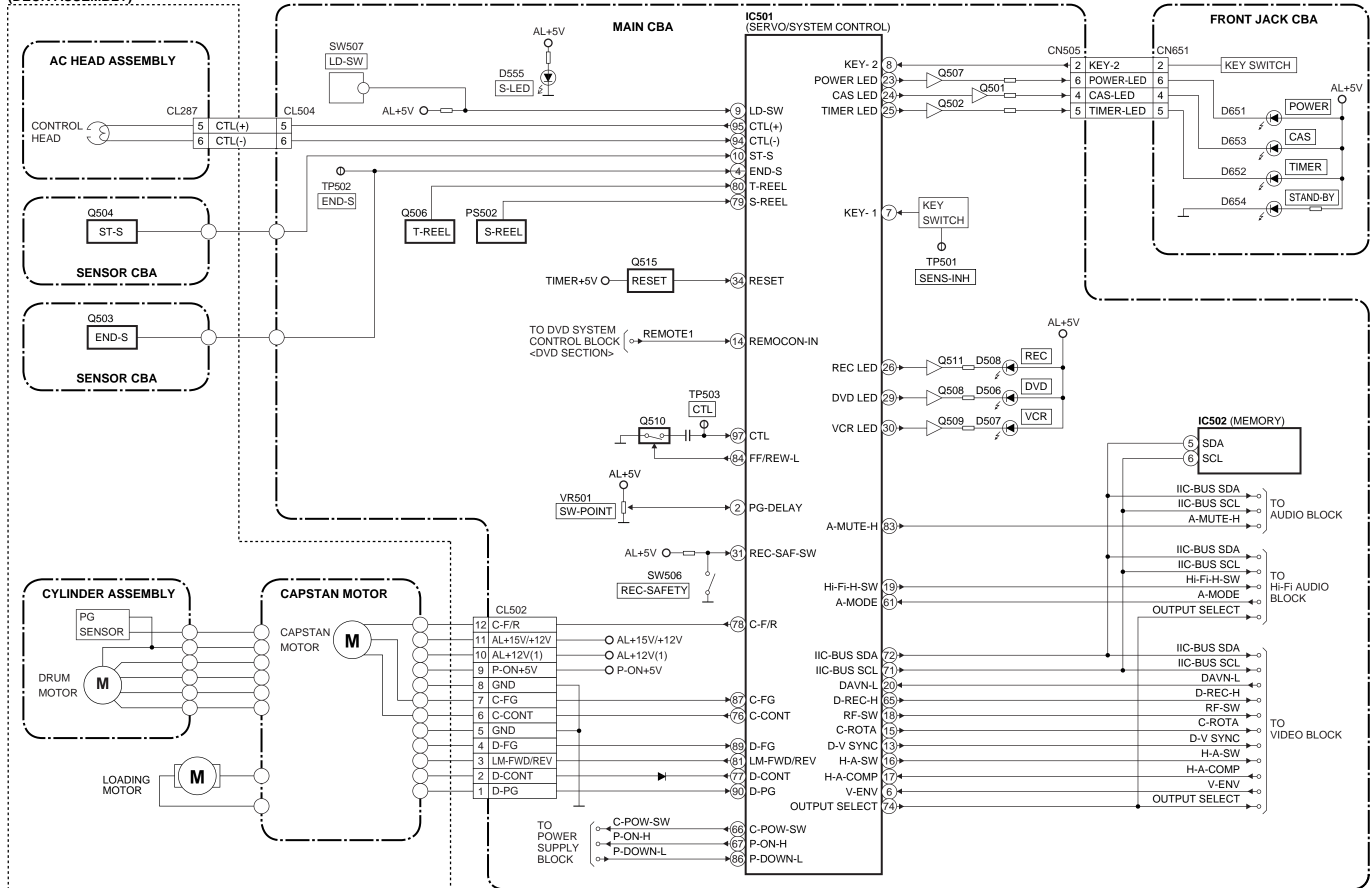
# DVD Main 4/4 Schematic Diagram



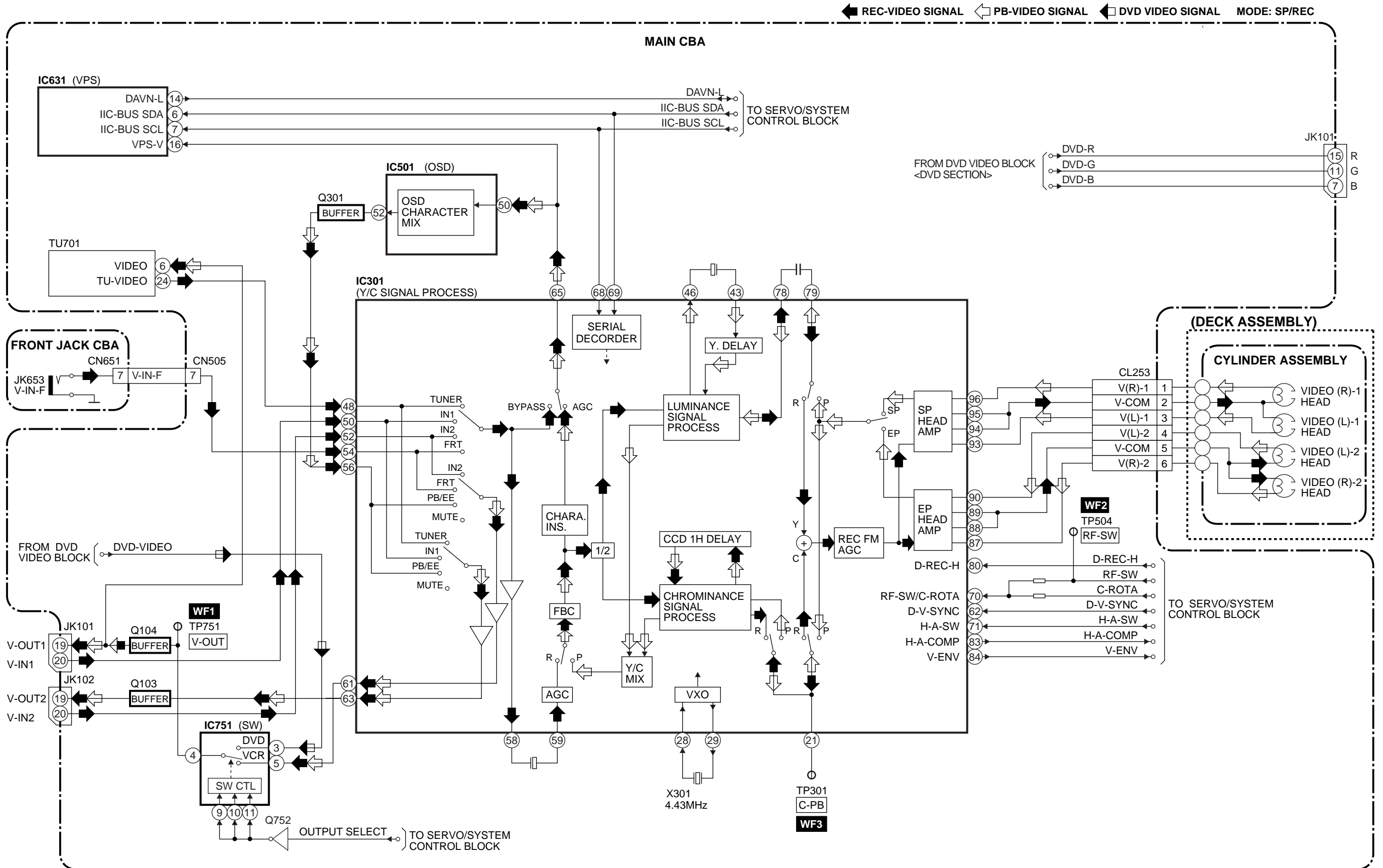
# BLOCK DIAGRAMS < VCR SECTION >

## Servo/System Control Block Diagram

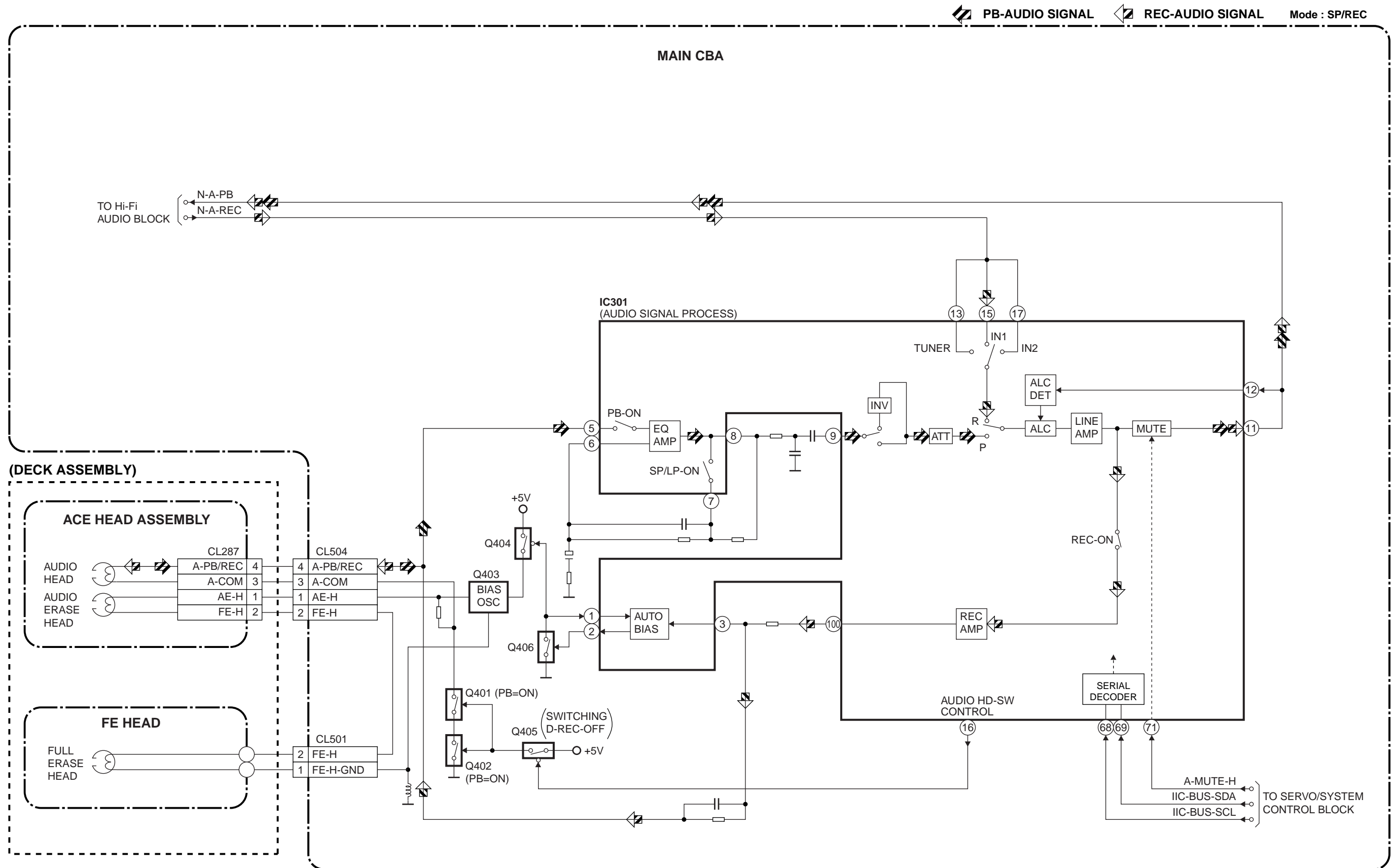
(DECK ASSEMBLY)



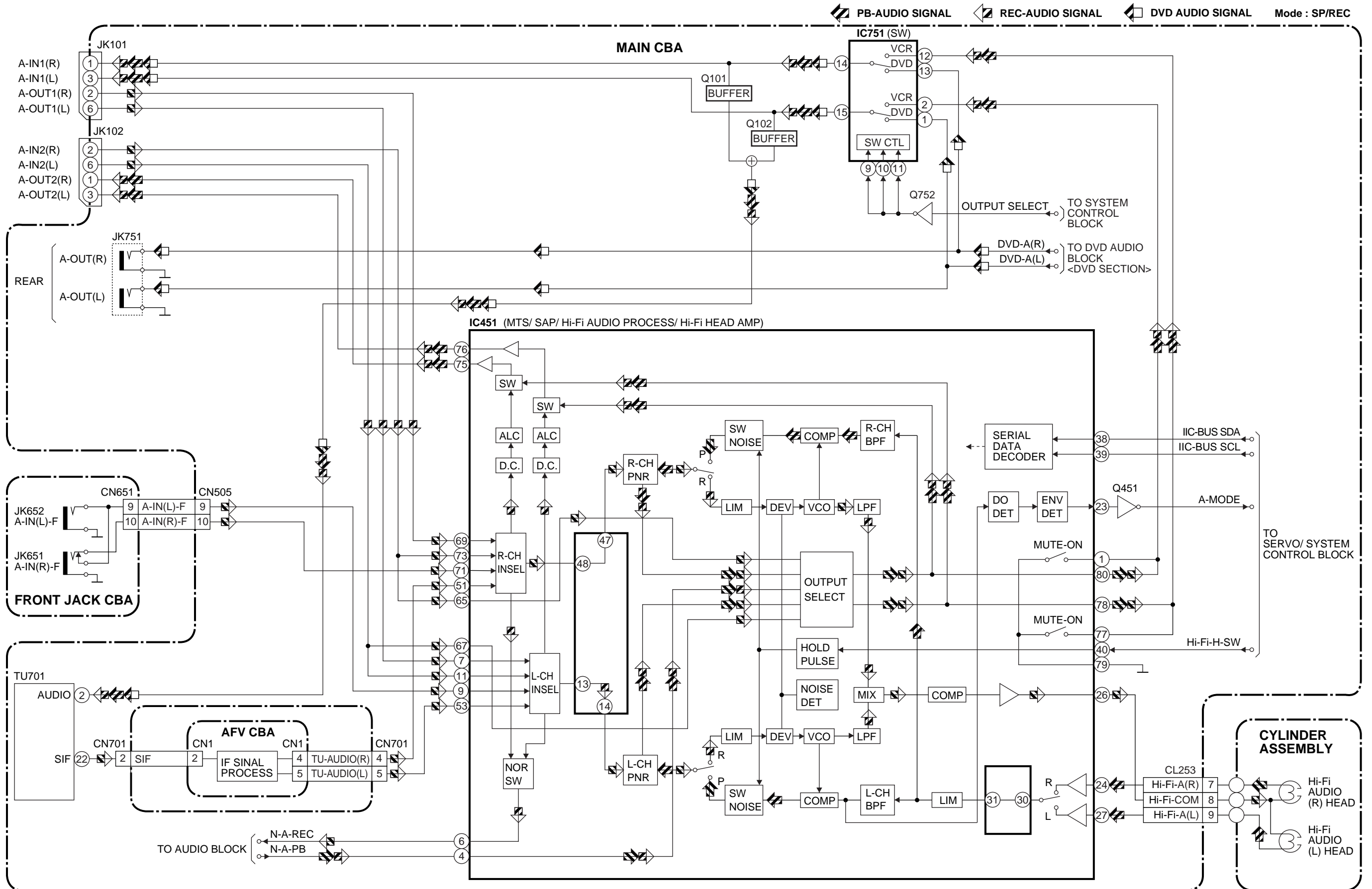
# Video Block Diagram



# Audio Block Diagram



# Hi-Fi Audio Block Diagram



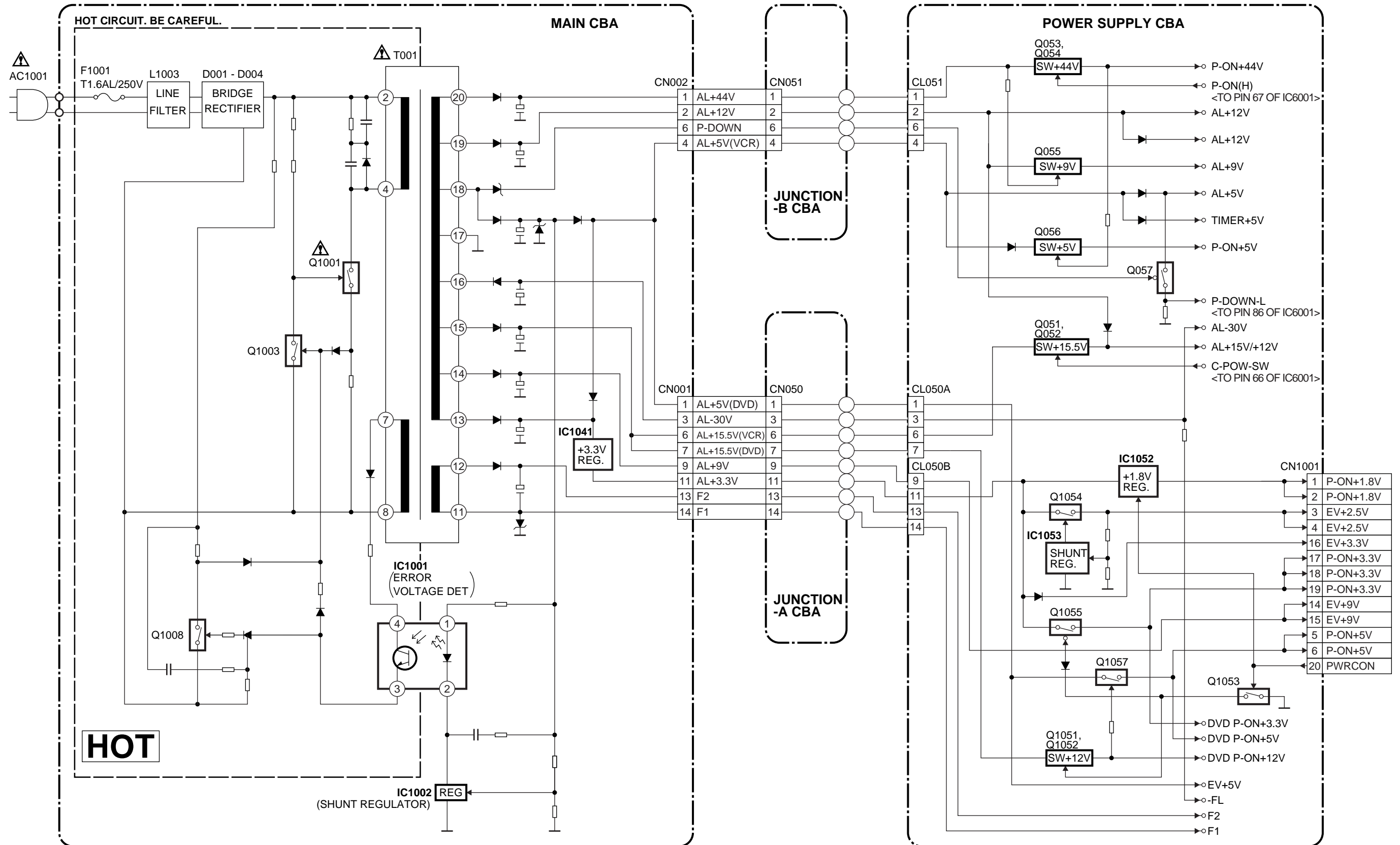


# Power Supply Block Diagram

**NOTE :**  
The voltage for parts in hot circuit is measured using hot GND as a common terminal.

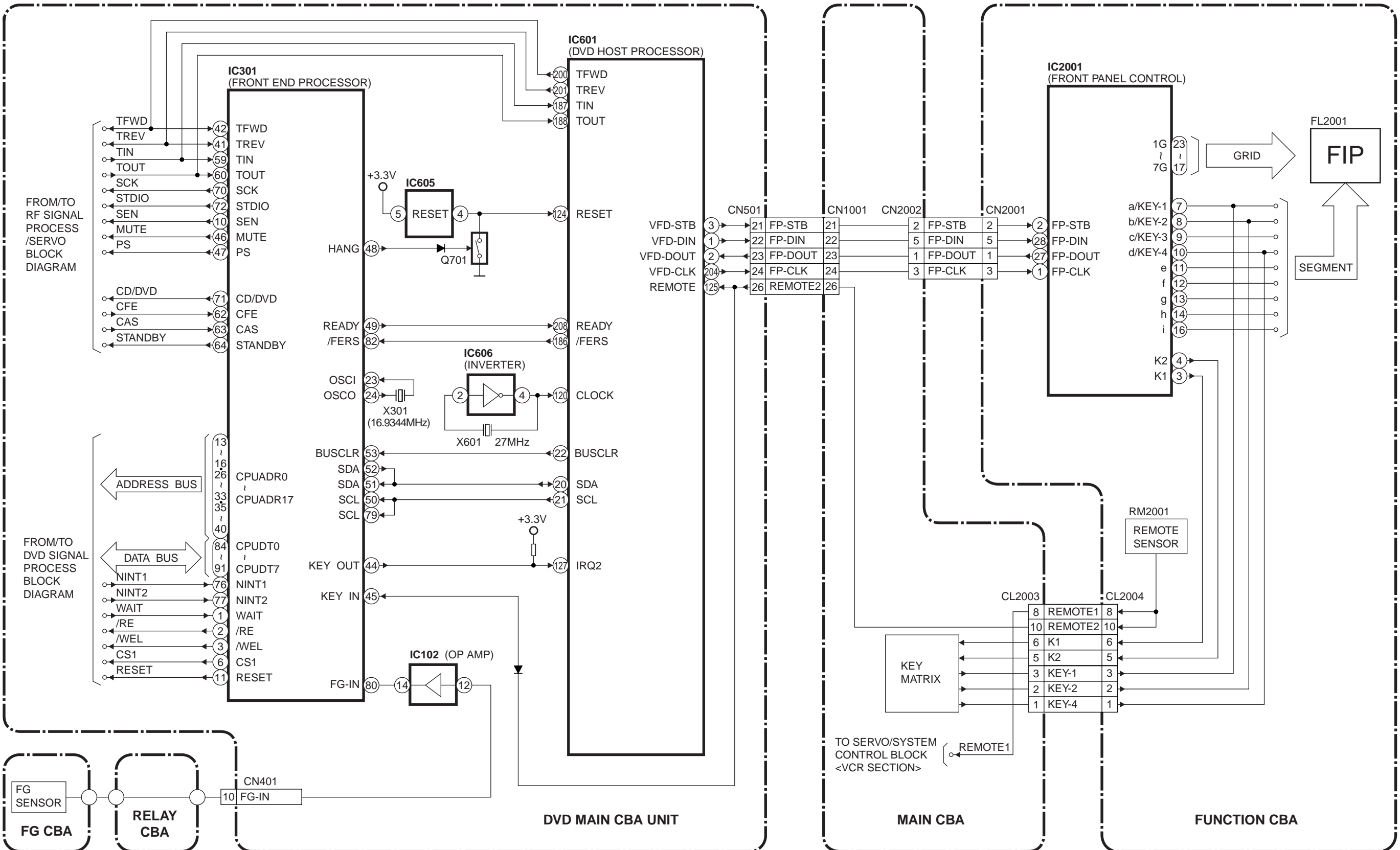
**CAUTION**  
FOR CONTINUED PROTECTION AGAINST FIRE HAZARD,  
REPLACE ONLY WITH THE SAME TYPE T1.6AL/250V FUSE.

**CAUTION !**  
Fixed voltage (or Auto voltage selectable ) power supply circuit is used in this unit.  
If Main Fuse (F001) is blown, check to see that all components in the power supply circuit are not defective before you connect the AC plug to the AC power supply.  
Otherwise it may cause some components in the power supply circuit to fail.

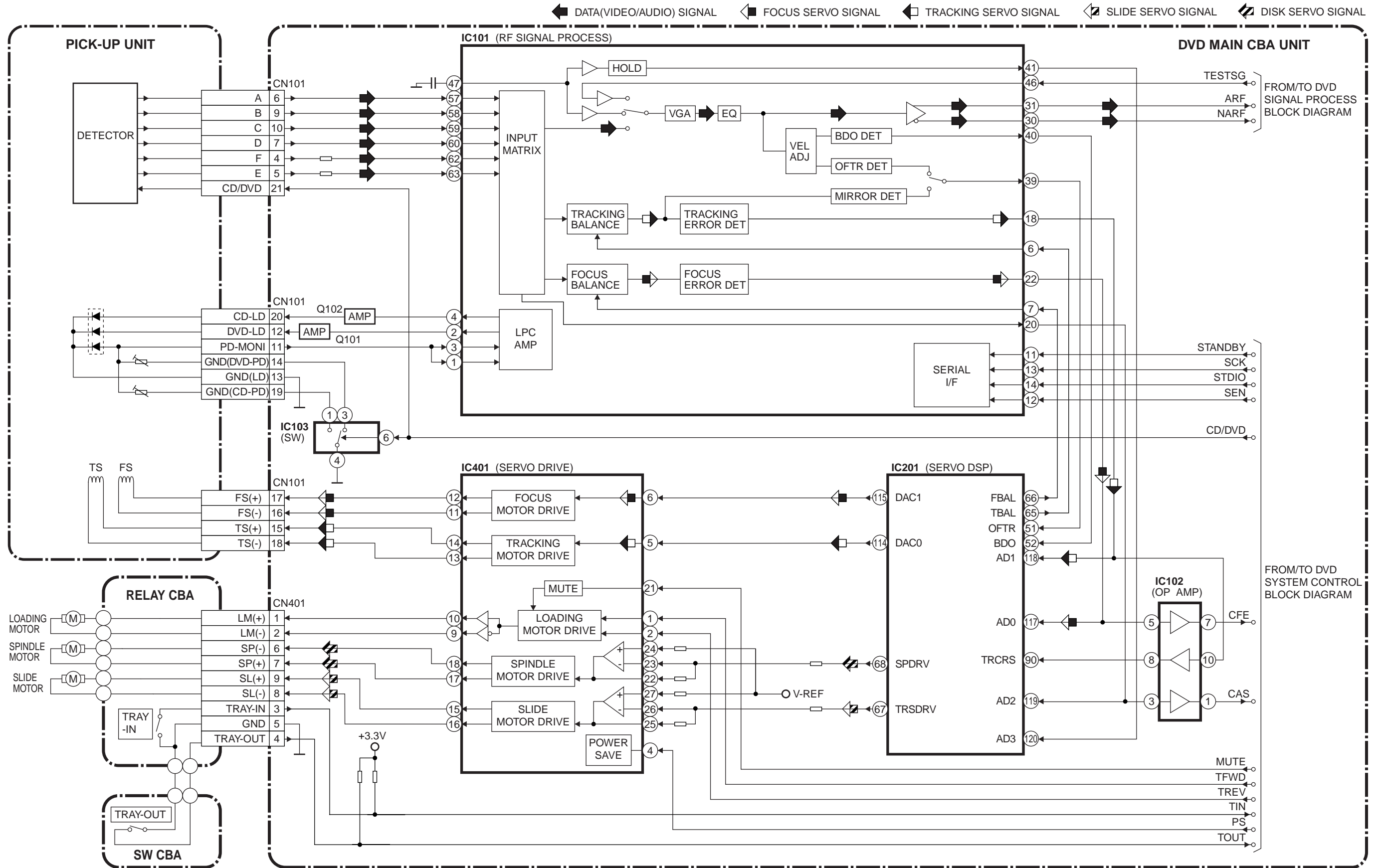


# BLOCK DIAGRAMS < DVD SECTION >

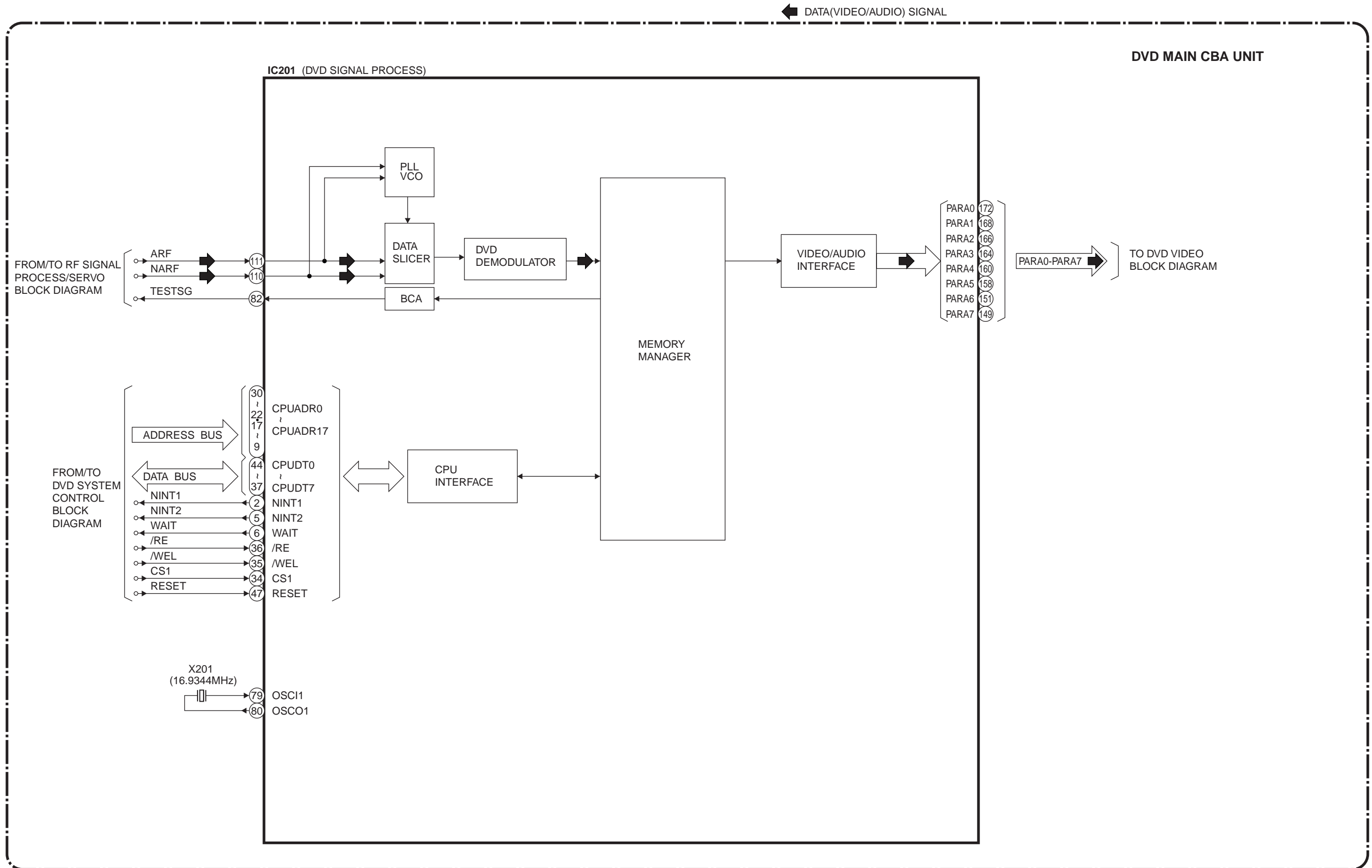
## DVD System Control Block Diagram



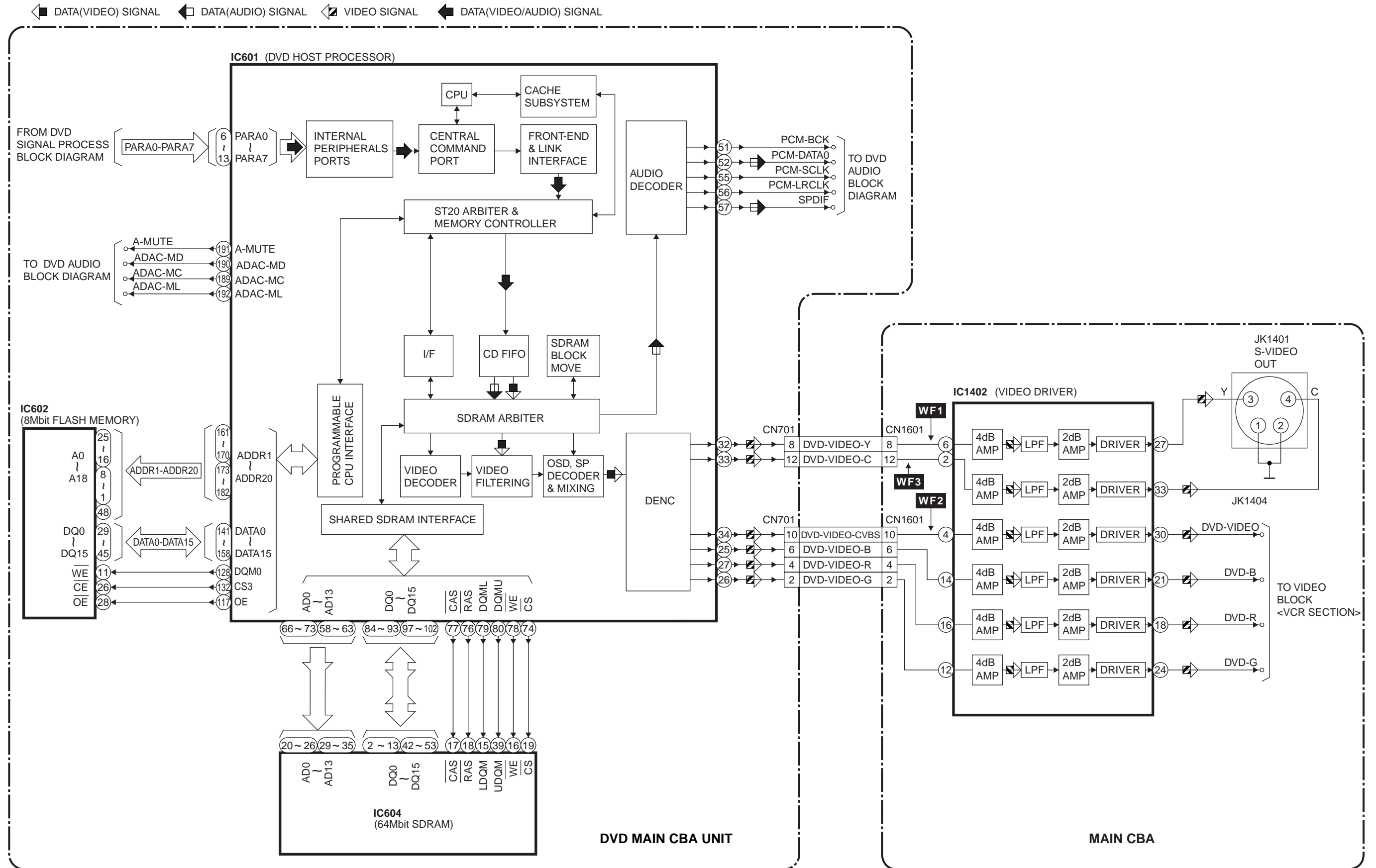
# RF Signal Process/Servo Block Diagram



# DVD Signal Process Block Diagram

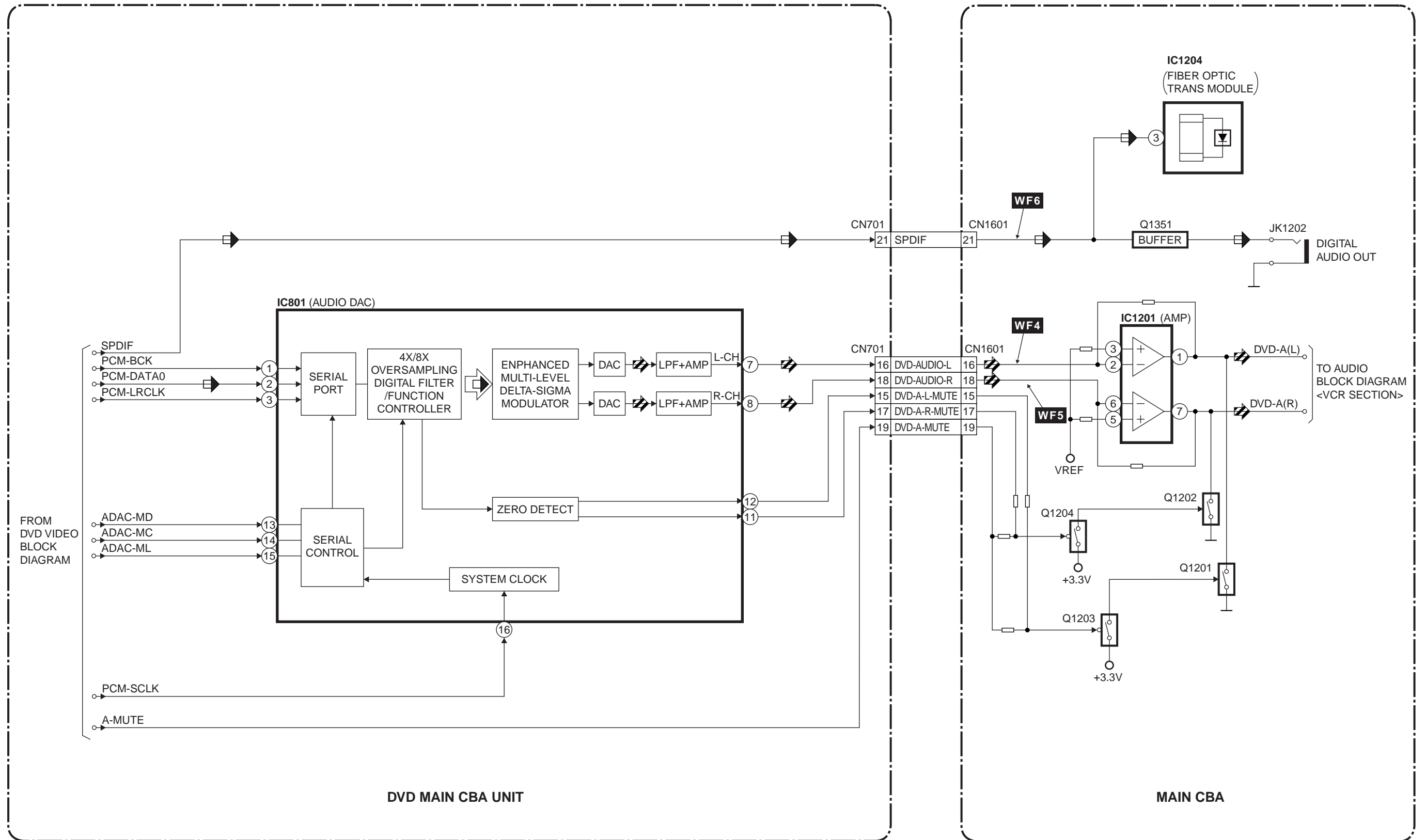


# DVD Video Block Diagram



# DVD Audio Block Diagram

◀ DATA(AUDIO) SIGNAL    ⚡ AUDIO SIGNAL



# SYSTEM CONTROL TIMING CHARTS

Mode SW : LD-SW

LD-SW Position detection A/D Input voltage Limit (Calculated voltage)	Symbol
3.76V~4.50V (4.12V)	EJ
4.51V~5.00V (5.00V)	CL
0.00V~0.25V (0.00V)	SB
1.06V~1.50V (1.21V)	TL
0.66V~1.05V (0.91V)	FB
1.99V~2.60V (2.17V)	SF
1.51V~1.98V (1.80V)	AU
3.20V~3.75V (3.40V)	AL
0.26V~0.65V (0.44V)	SS
4.51V~5.00V (5.00V)	GC
2.61V~3.19V (2.97V)	RS

↑ Note:

Note :

EJ → RS: Loading FWD (LM-FWD "H", LM-REV "L")

RS → EJ: Loading REV (LM-FWD "L", LM-REV "H")

Stop (A) = Loading

Stop (B) = Unloading

Note :

Symbol	Loading Status
EJ	Eject
CL	Eject ~ REW Reel
SB	REW Reel ~ Stop(B)
TL	Stop(B) ~ Brake Cancel
FB	Brake Cancel
SF	~ Stop(A)
AU	Stop(A) ~ Play / REC
AL	Play / REC ~ Still / Slow
SS	Still / Slow ~ Capstan Reversal
GC	Capstan Reversal ~ RS (REW Search)
RS	RS (REW Search)

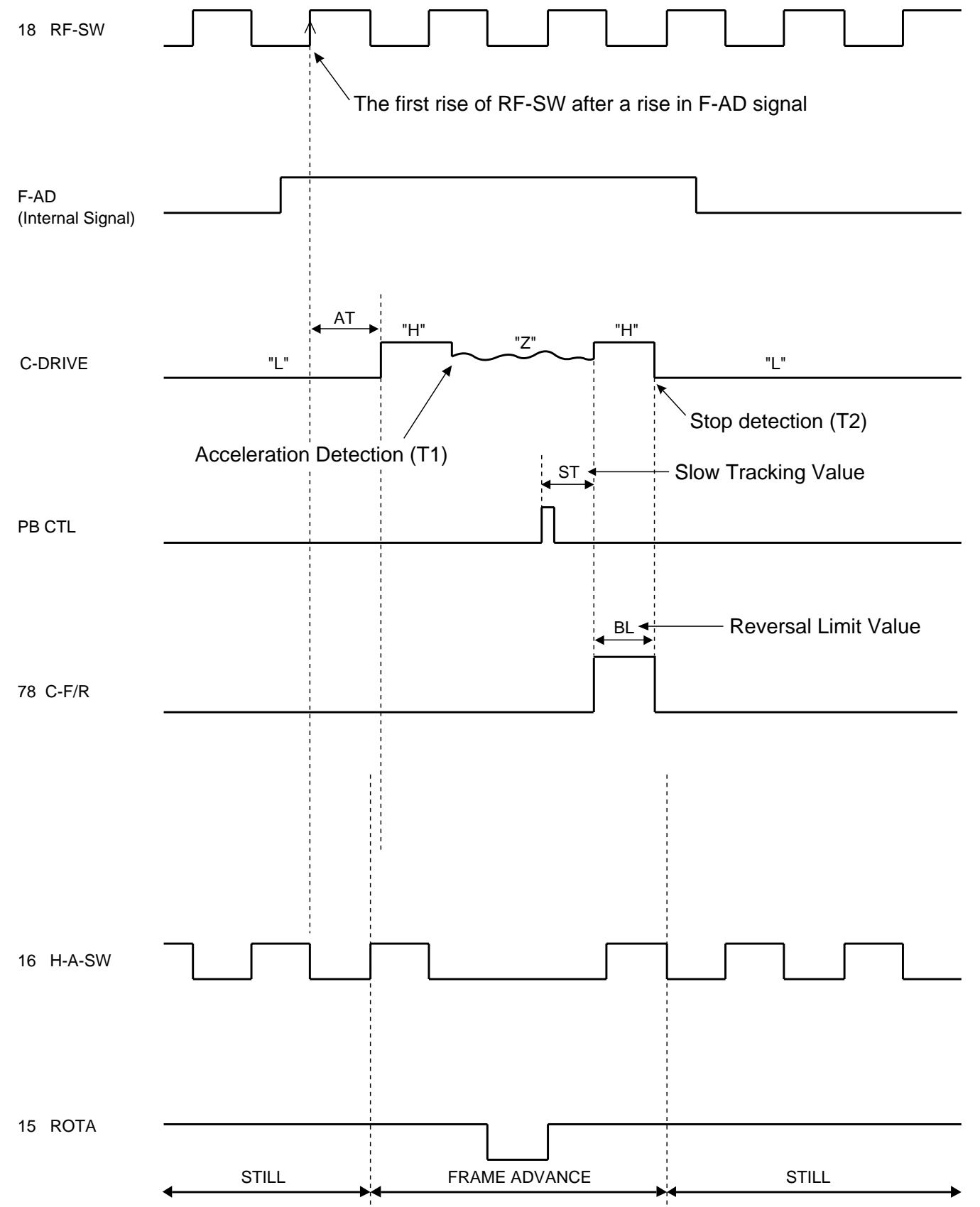


Fig. 1

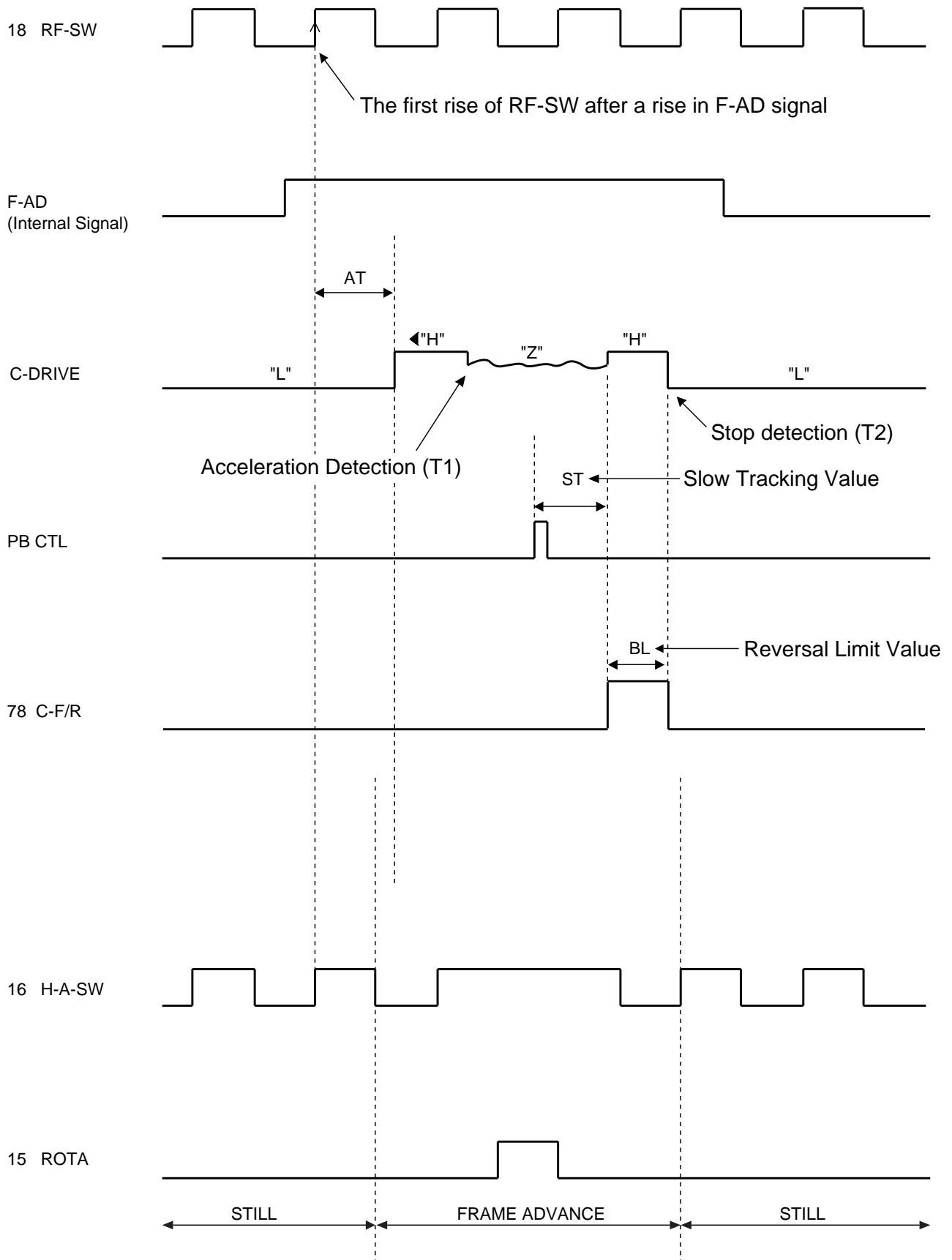


Fig. 2



1. EJECT (POWER OFF) -> CASSETTE IN (POWER ON) -> STOP(B) -> STOP(A) -> PLAY -> RS -> FS -> PLAY -> STILL -> PLAY -> STOP(A)

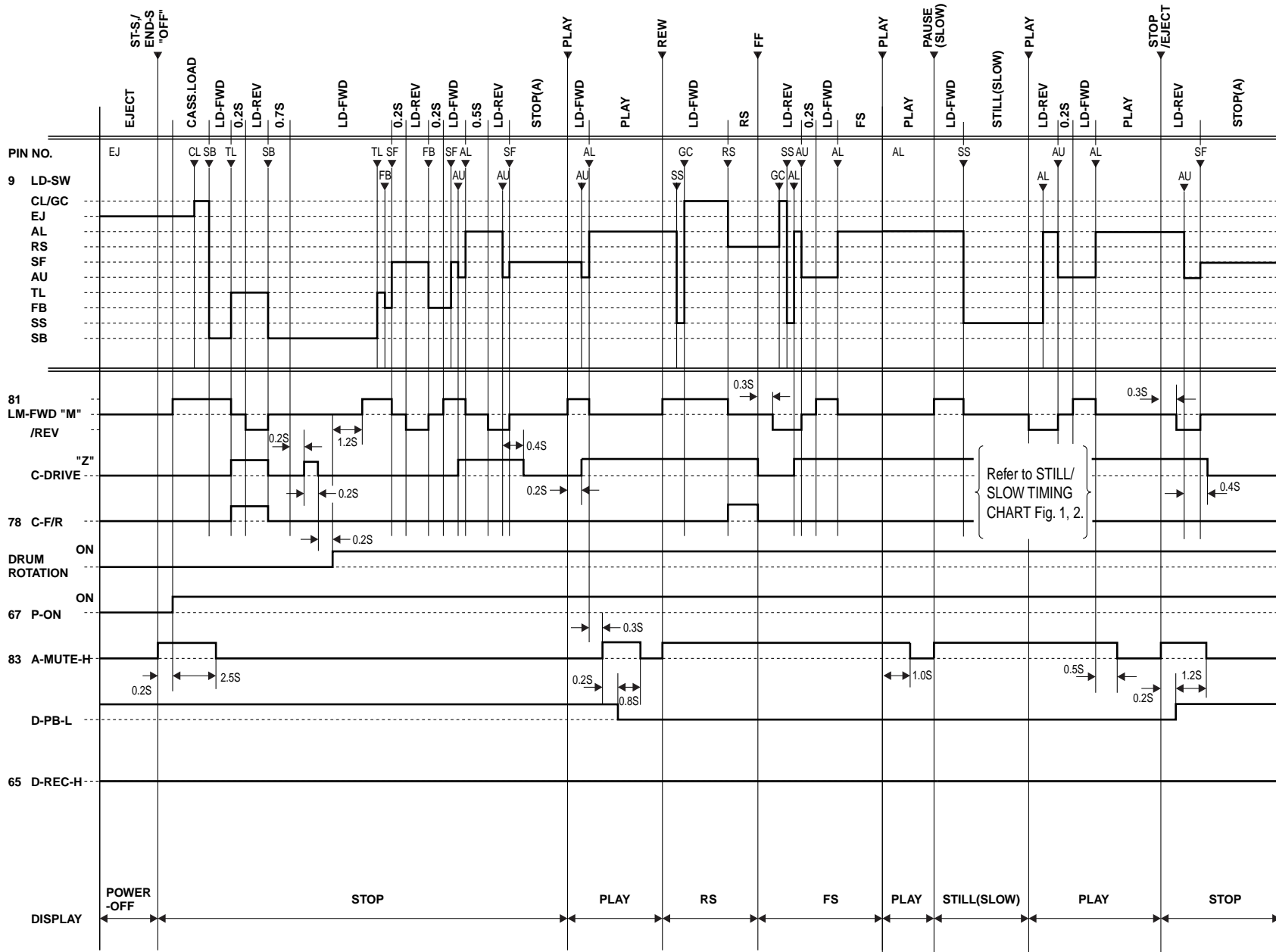


Fig. 3

2. STOP(A) -> FF -> STOP(A) -> REW -> STOP(A) -> REC -> PAUSE -> PAUSE or REC -> STOP(A) -> EJECT

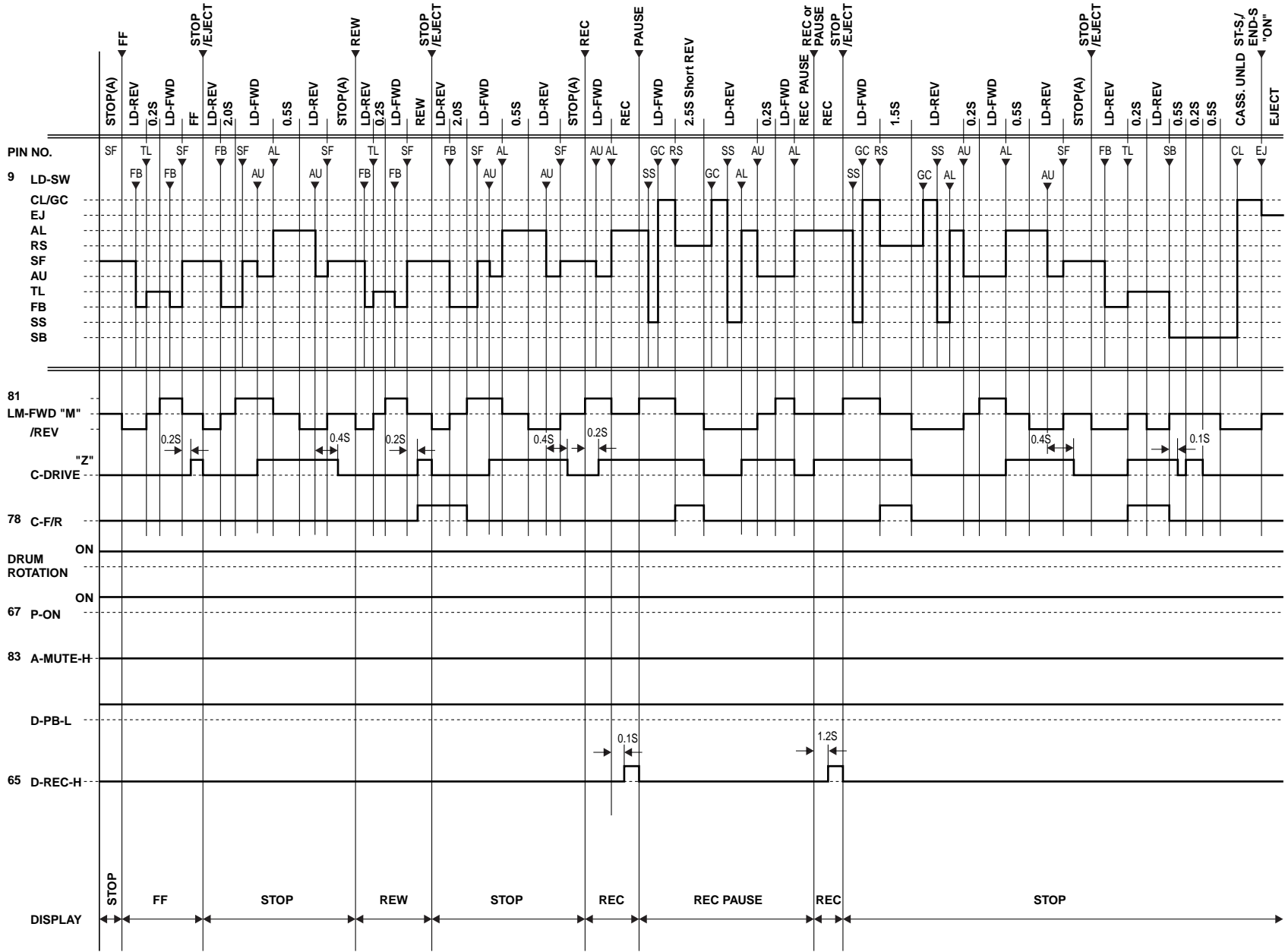
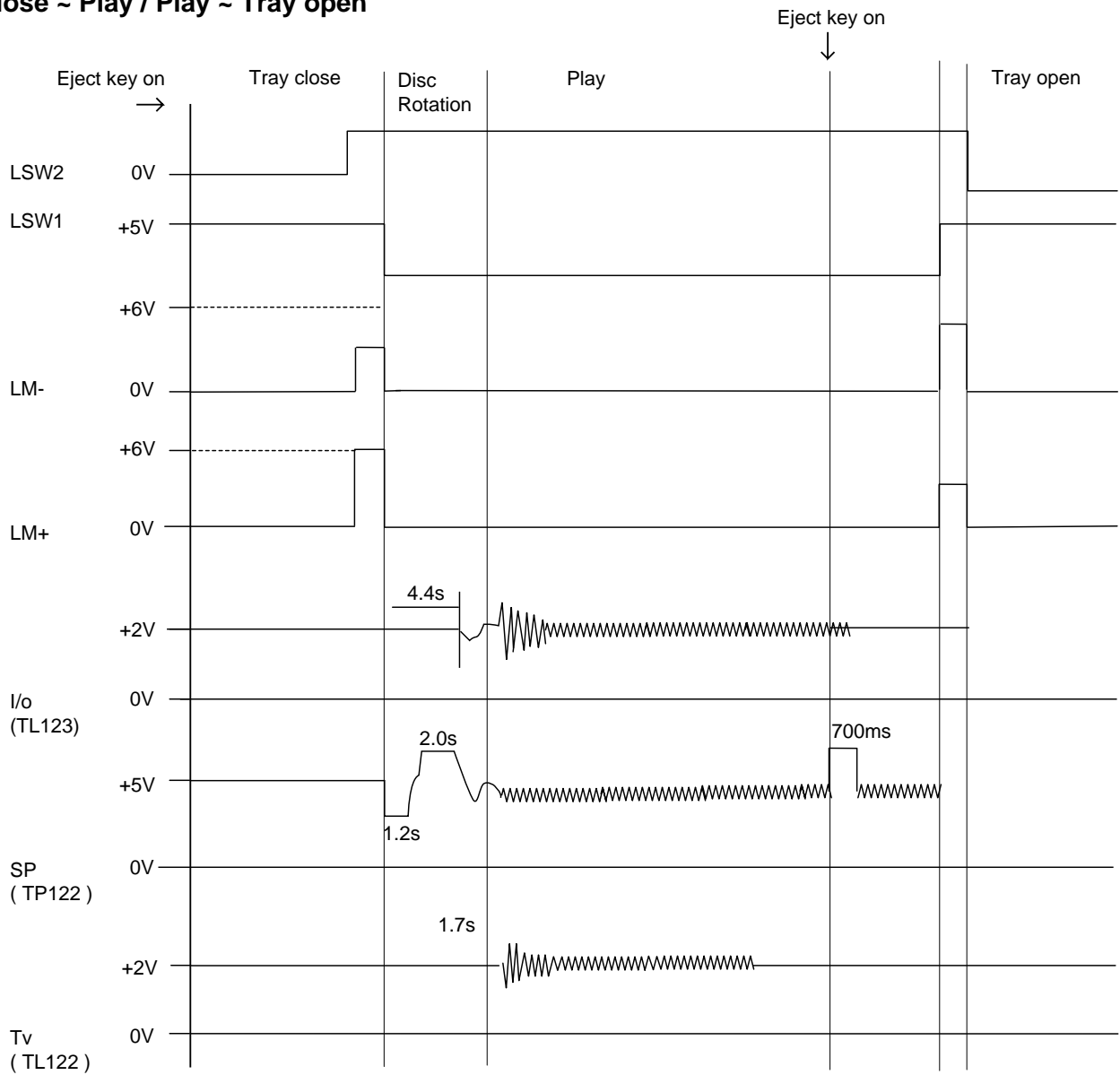


Fig. 4

# [ DVD Section ]

## Tray close ~ Play / Play ~ Tray open



# IC PIN FUNCTION DESCRIPTIONS

## [ VCR Section ]

### IC501( SERVO / SYSTEM CONTROL IC )

“H” ≥ 4.5V, “L” ≤ 1.0V

Pin No.	IN/ OUT	Signal Name	Function	Active Level
1	IN	SC2-IN	Input Signal from Pin 8 of SCART2	L/Hi-z
2	IN	PG-DELAY	Video Head Switching Pulse Signal Adjusted Voltage	A/D
3	IN	POW-SAF	P-ON Power Detection Input Signal	A/D
4	IN	END-S	Tape End Position Detect Signal	A/D
5	IN	AFC	Automatic Frequency Control Signal	A/D
6	IN	V-ENV	Video Envelope Comparator Signal	A/D
7	IN	KEY-1	Key Scan Input Signal 1	A/D
8	IN	KEY-2	Key Scan Input Signal 2	A/D
9	IN	LD-SW	Deck Mode Position Detector Signal	A/D
10	OUT	ST-S	Tape Start Position Detector Signal	A/D
11	-	N.U.	Not Used	-
12	-	N.U.	Not Used	-
13	OUT	D-V-SYNC	Dummy V-sync Output	H/Hi-z
14	IN	REMOCON	Remote Control Sensor	L
15	OUT	C-ROTA	Color Phase Rotary Changeover Signal	H/L
16	OUT	H-A-SW	Video Head Amp Switching Pulse	H/L
17	IN	H-A-COMP	Head Amp Comparator Signal	H/L
18	OUT	RF-SW	Video Head Switching Pulse	H/L
19	OUT	Hi-Fi-H-SW	HiFi Audio Head Switching Pulse	H/L
20	IN	DAVN-L	VPS/PDC Data Receive = “L”	L
21	-	N.U.	Not Used	-
22	-	N.U.	Not Used	-

Pin No.	IN/ OUT	Signal Name	Function	Active Level
23	OUT	POWER LED	“POWER” LED Signal Output	H/L
24	OUT	CAS LED	“CASSETTE” LED Signal Output	H/L
25	OUT	TIMER LED	“TIMER” LED Signal Output	H/L
26	OUT	REC LED	“REC” LED Signal Output	H/L
27	-	N.U.	Not Used	-
28	OUT	RGB-THROUGH	SCART 2 RGB Through Control Signal	L/Hi-z
29	OUT	DVD LED	“DVD” LED Signal Output	H/L
30	OUT	VCR LED	“VCR” LED Signal Output	H/L
31	IN	REC-SAF-SW	Recoding Safety SW Detect (With Record tab=“L”/ With out Record tab=“H”)	H/L
32	-	N.U.	Not Used	-
33	-	N.U.	Not Used	-
34	IN	RESET	System Reset Signal (Reset=“L”)	L
35	IN	XCIN	Sub Clock	-
36	OUT	XCOUT	Sub Clock	-
37	-	Vcc	Vcc	-
38	IN	XIN	Main Clock Input	-
39	OUT	XOUT	Main Clock Input	-
40	-	Vss	Vss(GND)	-
41	-	N.U.	Not Used	-
42	-	DVD-8PIN-IN	SCART 8Pin DVD Input Control Signal	H/L
43	IN	CLKSEL	Clock Select (GND)	L
44	IN	OSCIN	Clock Input for letter size	-
45	OUT	OSCOU	Clock Output for letter size	-
46	-	NUB	Not Used	-
47	-	PG/LP	PG/LP	-
48	IN	FSC-IN [4.43MHz]	4.43MHz Clock Input	-
49	-	OSDVss	OSDVss	-
50	IN	OSD-V-IN	OSD Video Signal Input	-
51	-	N.U.	Not Used	-

Pin No.	IN/ OUT	Signal Name	Function	Active Level
52	OUT	OSD-V-OUT	OSD Video Signal Output	-
53	-	OSDVcc	OSDVcc	-
54	-	HLF	LPF Connected Terminal (Slicer)	-
55	-	N.U.	Not Used	-
56	-	N.U.	Not Used	-
57	-	N.U.	Not Used	-
58	-	N.U.	Not Used	-
59	OUT	8POUT-1	SCART 1 8Pin Output Control Signal	H/L
60	OUT	8POUT-2	SCART 2 8Pin Output Control Signal	H/L
61	IN	A-MODE	Hi-Fi Tape Detection Signal	L
62	-	N.U.	Not Used	-
63	-	N.U.	Not Used	-
64	-	N.U.	Not Used	-
65	OUT	D-REC-H	Delayed Record Signal	L
66	OUT	C-POWER-SW	Capstan Power Switching Pulse	L/Hi-z
67	IN	P-ON-H	Power On Signal at High	H
68	-	N.U.	Not Used	-
69	-	N.U.	Not Used	-
70	-	N.U.	Not Used	-
71	OUT	IIC-BUS-SCL	IIC BUS Control Clock	H/L
72	IN/ OUT	IIC-BUS-SDA	IIC BUS Control Data	H/L
73	-	N.U.	Not Used	-
74	OUT	OUTPUT-SELECT	Output Select	H/L
75	-	DVD-POWER-MONITOR	DVD Power Monitor Signal (P-off="H", P-on="L")	H/L
76	OUT	C-CONT	Capstan Motor Control Signal	PWM
77	OUT	D-CONT	Drum Motor Control Signal	PWM
78	OUT	C-F/R	Capstan Motor FWD/REV Control Signal (FWD="L"/REV="H")	H/L
79	IN	S-REEL	Supply Reel Rotation Signal	PULSE
80	IN	T-REEL	Take Up Reel Rotation Signal	PULSE

Pin No.	IN/ OUT	Signal Name	Function	Active Level
81	OUT	LM-FWD/REV	Loading Motor Control Signal	H/L/Hi-z
82	OUT	DVD-POWER	DVD Power Control Signal	L
83	OUT	A-MUTE-H	Audio Mute Control Signal (Mute = "H")	H
84	OUT	FF/REW-L	CTL Amp Gain Switching Signal (FF/REW="L")	L
85	-	N.U.	Not Used	-
86	IN	P-DOWN-L	Power Voltage Down Detector Signal	L
87	IN	C-FG	Capstan Motor Rotation Detection Pulse	PULSE
88	-	AMPVss	AMPVss (GND)	-
89	IN	D-FG	Drum Motor Rotation Detection Pulse	PULSE
90	IN	D-PG	Drum Motor Pulse Generator	PULSE
91	-	N.U.	Not Used	-
92	-	AMPVRE <sub>FIN</sub>	V-Ref for CTL AMP	-
93	-	C	C Terminal	-
94	OUT	CTL (-)	Playback/Record Control Signal (-)	H/L
95	OUT	CTL (+)	Playback/Record Control Signal (+)	H/L
96	-	AMPC	CTL AMP Connected Terminal	-
97	-	CTLAMP out	To Monitor for CTL AMP Output	PULSE
98	-	AMPVcc	AMPVcc	-
99	-	AVcc	A/D Converter Power Input/ Standard Voltage Input	-
100	IN	AGC	IF AGC Control Signal	H/L/Hi-z

**Notes:**

Abbreviation for Active Level:

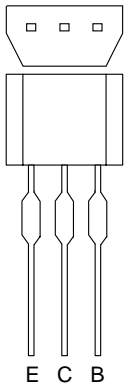
PWM -----Pulse Wide Modulation

A/D-----Analog - Digital Converter

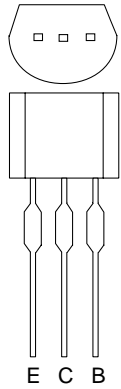
## IC2001 [ PT6315-S(TP) ]

Pin No.	In/Out	Signal Name	Name Function
1	In	CLK	Clock Input
2	In	STB	Serial Interface Strobe
3	In	K1	Key Data 1 Input
4	In	K2	Key Data 2 Input
5	-	VSS	GND
6	-	VDD	Power Supply
7	Out	a / KEY-1	Segment Output / Key Souce-1
8	Out	b / KEY-2	Segment Output / Key Souce-2
9	Out	c	Segment Output
10	Out	d / KEY-4	Segment Output/ Key Souce-4
11	Out	e	Segment Output
12	In	f	
13	In	g	
14	Out	h	
15	-	VEE	Pull Down Level
16	Out	i	Segment Output
17	Out	7G	Grid Output
18		6G	
19		5G	
20		4G	
21		3G	
22		2G	
23		1G	
24	-	VDD	Power Supply
25	-	VSS	GND
26	In	OSC	Oscillator Input
27	Out	DOUT	Serial Data Output
28	In	DIN	Serial Data Input

# LEAD IDENTIFICATIONS

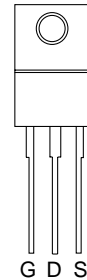


BN1F4M-T  
BA1F4M-T  
KTA1266(GR)  
KTC3199(Y,GR,BL)  
2SC2785(J,H,F,K)  
KRC103M  
KRA103M  
BN1L3Z(P)  
KRA110M  
KTA1273(Y)  
KTA1281(Y)  
KRA104M  
BN1L4M-T  
KRC110M-AT  
BA1L3Z-T

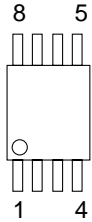


2SC1815-BL(TPE2)  
2SC1815-Y(TPE2)  
2SC1815-GR(TPE2)  
2SC2120-Y(TPE2)  
KTC3203(Y)  
KTC3205 (Y)  
2SA966(Y)  
2SC2001(K,L)  
2SA1020(Y)  
2SB892(S)  
2SC3266-Y(TPE2)  
2SA1015-GR(TPE2)

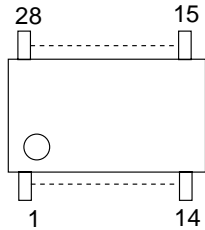
FS2KM-18A  
KIA78R33PI  
PQ3RD13(1A)



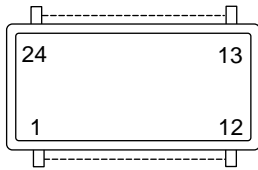
NJM4558D  
KIA4558P



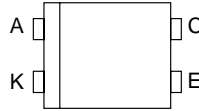
PT6315-S-(TP)



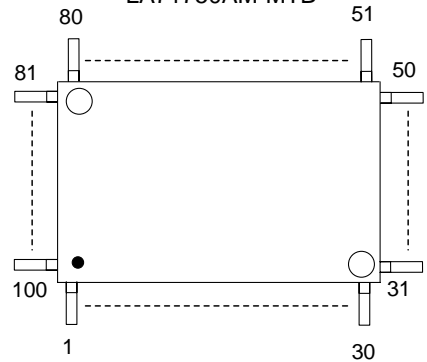
LC74793JM-TRM



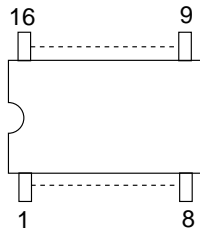
LTV-817(B,C)-F



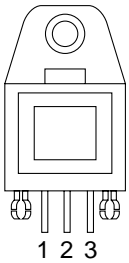
QSZAD0RMB132  
QSZAB0RMB132  
QSZAC0RMB132  
LA71750AM-MTB



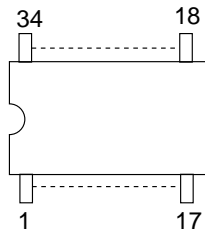
TC4053BF(N)  
BU4053BCF-E2



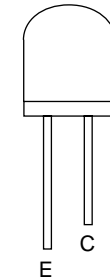
OC-0805T-002  
GP1FA512TZV



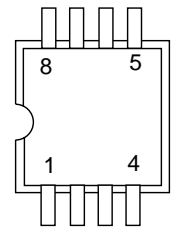
MM1567AJBE



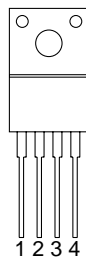
MID-32A22  
PT204-6B-12



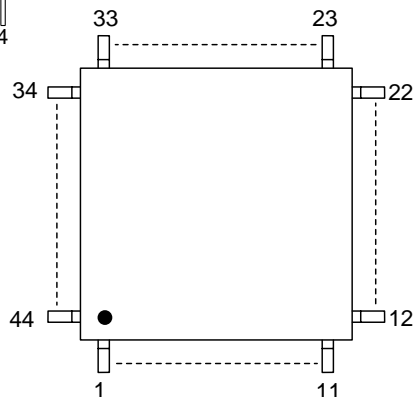
BR24C02F-W  
AT24C02N-10SC  
M24C02-MN6T  
CAT24WC02JI



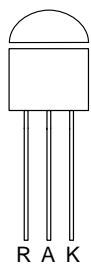
PQ018EF01SZ



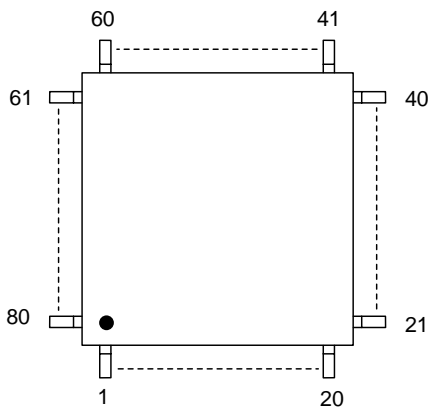
MSP3417G-QG-B8-V3  
MSP3417G-QG-B8



KIA431-AT



LA72646M-A-MPB



**Note:**

- A: Anode
- K: Cathode
- E: Emitter
- C: Collector
- B: Base
- R: Reference
- S: Source
- G: Gate
- D: Drain

# HITACHI

Hitachi, Ltd. Tokyo, Japan  
International Sales Division  
THE HITACHI ATAGO BUILDING,  
No. 15-12 Nishi Shinbashi, 2-Chome,  
Minato-Ku, Tokyo 105-8430, Japan.  
Tel: 03 35022111

## HITACHI EUROPE LTD.

Dukes Meadow  
Millboard Road  
Bourne End  
Buckinghamshire  
SL8 5XF

### UNITED KINGDOM

Tel: 01628 643000

Fax: 01628 643400

Email: [consumer-service@hitachi-eu.com](mailto:consumer-service@hitachi-eu.com)

## HITACHI EUROPE S.A.

364, Kifissias Ave. & 1, Delfon Str.  
152 33 Chalandri

Athens

### GREECE

Tel: 1-6837200

Fax: 1-6835694

Email: [service.hellas@hitachi-eu.com](mailto:service.hellas@hitachi-eu.com)

## HITACHI EUROPE GmbH

Munich Office  
Dornacher Strasse 3  
D-85622 Feldkirchen bei München

### GERMANY

Tel: +49-89-991 80-0

Fax: +49-89-991 80-224

Hotline: +49-180-551 25 51 (12ct/min.)

Email: [HSE-DUS.Service@Hitachi-eu.com](mailto:HSE-DUS.Service@Hitachi-eu.com)

## HITACHI EUROPE S.A.

Gran Via Carlos III, 101 - 1  
08028 Barcelona

### SPAIN

Tel: 93 409 2550

Fax: 93 491 3513

Email: [rplan@hitachi-eu.com](mailto:rplan@hitachi-eu.com)

## HITACHI EUROPE SRL

Via T. Gulli n.39  
20147 MILAN

### ITALY

Tel: 02 487861

Fax: 02 48786381

Servizio Clienti

Tel. 02 38073415

Email: [customerservice.italy@hitachi-eu.com](mailto:customerservice.italy@hitachi-eu.com)

## HITACHI EUROPE AB

Box 77

S-164 94 KISTA

### SWEDEN

Tel: 08 562 711 00

Fax: 08 562 711 11

Email: [csgswe@hitachi-eu.com](mailto:csgswe@hitachi-eu.com)

## HITACHI EUROPE S.A.S

Lyon Office  
B.P. 45, 69671 Bron Cedex

### FRANCE

Tel: 04 72 14 29 70

Fax: 04 72 14 29 99

Email: [france.consommateur@hitachi-eu.com](mailto:france.consommateur@hitachi-eu.com)

## HITACHI EUROPE LTD.

Norwegian Branch Office  
Strandveien 18  
1366 Dysaker

### NORWAY

Tel: 02205 9060

Fax: 02205 9061

Email: [csgnor@hitachi-eu.com](mailto:csgnor@hitachi-eu.com)

## ITEM N.V./S.A. (INTERNATIONAL TRADE FOR ELECTRONIC MATERIAL & MEDIA N.V./S.A)

UCO Tower - Bellevue, 17  
B - 9050 GENT

### BELGIUM (for BENELUX)

Tel: 09 230 48 01

Fax: 09 230 96 80

Email: [hitachi.item@skynet.be](mailto:hitachi.item@skynet.be)

[www.hitachi-consumer-eu.com](http://www.hitachi-consumer-eu.com)

**No. 9208E**

**July 2002**